

**LOS ANGELES COUNTY
DEPARTMENT OF PUBLIC WORKS**

HYDROLOGIC REPORT

1992-93

PREPARED BY THE
HYDRAULIC/WATER CONSERVATION DIVISION
JULY 1994

TABLE OF CONTENTS

Credits	1
Introduction	2
The Los Angeles County	3
Flood Control and Water Conservation	7

PRECIPITATION

General Discussion	A1
Los Angeles County Rainfall Indices	A2
Location Map of Rain Gages	PA1
Active Rainfall Stations	A3
Isohyetal Map (1992-93 Storm Season)	PA2
Isohyetal Map (Feb. 9-13, 1992 Storm)	PA3

EVAPORATION

General Discussion/Evaporation Station List	B1
Summary of Monthly Evaporation Amounts at Selected Station	B2
Location Map of Evaporation Stations	PB1

RUNOFF

General Discussion	C1
Location Map of Streamflow Recording Stations	PC1
Index of Stream Gaging Stations	C3
<u>Summary of Monthly Discharge Records at Selected Stations</u>	

STATION

NO.

STATION NAME

L1-R	LITTLE ROCK CREEK above Little Rock Dam	C5
------	---	----

Summary of Monthly Discharge Records at Selected Stations (cont.)

<u>STATION NO.</u>	<u>STATION NAME</u>	
U7-R	FISH CREEK above Mouth of Canyon	C6
U8-R	SAN GABRIEL RIVER below Morris Dam	C7
F34D-R	LOS ANGELES RIVER below Firestone Boulevard	C8
F37B-R	COMPTON CREEK near Greenleaf Drive	C9
F38C-R	BALLONA CREEK above Sawtelle Boulevard	C10
F42B-R	SAN GABRIEL RIVER above Spring Street	C11
F45B-R	RIO HONDO above Stewart and Gray Road	C12
F64-R	RIO HONDO above Mission Bridge	C13
F81D-R	ALHAMBRA WASH near Klingerman Street	C14
F82C-R	RUBIO WASH at Glendon Wash	C15
F92C-R	SANTA CLARA RIVER below Highway 5	C16
F122-R	PALLET CREEK at Valyermo Highway	C17
F125-R	SANTIAGO CREEK above Little Rock Creek	C18
F130B-R	MALIBU CREEK below Cold Creek	C19
F181-R	MONTEBELLO STORM DRAIN above Rio Hondo	C20
F190-R	SAN GABRIEL RIVER at Foothill Boulevard	C21
F192B-R	RIO HONDO below Lower Azusa Road	C22
F193B-R	SANTA ANITA WASH at Longden Avenue	C23
F194B-R	SAWPIT WASH below Live Oak Avenue	C24

Summary of Monthly Discharge Records at Selected Stations (cont.)

<u>STATION NO.</u>	<u>STATION NAME</u>	
F250-R	SAN GABRIEL - AZUSA CONDUIT at 25 ft. Weir below San Gabriel Dam	C25
F252-R	VERDUGO WASH at Estelle Avenue	C26
F261C-R	SAN GABRIEL RIVER below Valley Boulevard	C27
F262C-R	SAN GABRIEL RIVER above Florence Avenue	C28
F263C-R	SAN GABRIEL RIVER below San Gabriel River Parkway	C29
F274B-R	DALTON WASH at Merced Avenue	C30
F280-R	SANTA FE CHANNEL below Santa Fe Dam	C31
E285-R	BURBANK - WESTERN STORM DRAIN at Riverside Drive	C32
F300-R	LOS ANGELES RIVER at Tujunga Avenue	C33
F304-R	WALNUT CREEK above Puente Avenue	C34
F312-R	SAN JOSE CHANNEL above Workman Mill Road	C35
F317-R	ARCADIA WASH below Grand Avenue	C36
F318-R	EATON WASH at Loftus Drive	C37
F319-R	LOS ANGELES RIVER below Wardlow Road	C38
F328-R	MINT CANYON CREEK at Fitch Avenue	C39
F329-R	BRADBURY CHANNEL below Central Avenue	C40
F338-R	RUBIO DIVERSION CHANNEL below Gooseberry Canyon Inlet ...	C41
F342-R	BRANFORD STREET CHANNEL below Sharp Avenue	C42
F354-R	COYOTE CREEK below Spring Street	C43
F377-R	BOUQUET CANYON CREEK at Urbandale Avenue	C44

RESERVOIRS

General Discussion	D1
Location Map of District Reservoirs	PD1
<u>Dam Operation Records</u>	
BIG DALTON	D3
BIG TUJUNGA	D5
COGSWELL	D7
DEVIL'S GATE	D9
EATON WASH	D11
LIVE OAK	D13
PACOIMA	D15
PUDDINGSTONE	D17
PUDDINGSTONE DIVERSION	D19
SAN DIMAS	D21
SAN GABRIEL	D23
SANTA ANITA	D25
SAWPIT	D27
THOMPSON CREEK	D29

EROSION CONTROL

General Discussion	E1
Location Map of Debris Basins	PE1
Debris Basin-Design Data	E3

EROSION CONTROL (cont.)

Debris Basin-Debris Production History	E7
Burned Area Location Map	PE2

WATER QUALITY

General Discussion	F1
Total Dissolved Solids at Selected Surface Stations	F4
Monthly Monitoring - Los Angeles River at Wardlow Road	F5

Groundwater Quality Well Locations

San Fernando Valley	PF1
San Gabriel Valley	PF2
Coastal Plain	PF3
Santa Clara Valley	PF4
Antelope Valley	PF5

Surface Water Quality Monitoring Locations

Monitor Group 1	PF6
Monitor Group 2	PF7

WATER CONSERVATION

General Discussion	G1
Data on Spreading Facilities owned by the Department	G9
Data on Spreading Facilities owned by Others	G13
Water Conserved in all Department Facilities	G14
Imported and Reclaimed Water Spread Amounts	G15

<u>Key Well Hydrographs (Listing and Locations)</u>	G17
Location Map	PG1
West Coast	G19
Central Basin	G21/23/25
Main San Gabriel	G27/29
San Gabriel Canyon	G31
Pomona	G33
Claremont Heights	G35
Raymond Basin	G37
Santa Clara Valley	G39
Antelope Valley	G41/43
Main San Fernando	G45/47
<u>Location Map of Water Conservation Facilities</u>	PG2
<u>Santa Clarita Valley Groundwater Basin</u>	PG3
<u>Groundwater Contour Maps</u>	
San Fernando Valley (Upper Los Angeles River Area)	PG4
San Gabriel Valley	PG5
Coastal Plain	PG6
Santa Clarita Valley	PG7

This report was prepared in the Hydraulic/Water Conservation Division under the direction of Robert D. Pedigo, Assistant Deputy Director. The following people contributed to the completion of this report:

General Supervision and Coordination

A. Gribnau

Supervision

A. Bentley
T. Su

Coordination

J. Keith
G. Farag

Collection and Computation

L. Amandy	S. Khoo
M. Bonaparte	S. Morrison
R. Brown	G. Phuong
D. Carpenter	A. Rodriguez
M. Cheung	K. Smith
J. Doughly	R. Sy
E. Esquerra	S. Tse
P. Gonda	R. Velez
P. Imaa	I. Wong
H. Khachikian	

Graphic Design, Layout, Art Production

K. Hu
R. Brown
J. Garcia
T. Gharib

INTRODUCTION

This report contains hydrologic data relative to Los Angeles County for the period beginning October 1, 1992 and ending September 30, 1993. The data are presented in seven sections.

Precipitation - lists 294 active rainfall stations and presents corresponding seasonal rainfall amounts.

Evaporation - lists all locations for which evaporation data is on file and provides monthly evaporation amounts at 14 locations.

Runoff - presents the maximum, minimum, and mean of the daily flow rates for each month and the monthly volumes for 40 streamflow stations.

Dam Operation - presents the maximum and minimum of the daily inflow and outflow rates for each month, the instantaneous peak inflow and outflow rates and storage volumes for 14 dams and reservoirs.

Erosion Control - lists debris basins and debris production amounts.

Water Quality Monitoring - presents maps of surface and groundwater sampling locations, and data at selected locations.

Conservation and Groundwater - presents records of water conserved at various facilities, water injected at seawater barrier projects, well hydrographs, and static groundwater contour maps.

Where practical, data which would satisfy immediate needs and serve as useful reference are published in these reports. Several tables appear listing locations for which unpublished data are available. Additional information may be obtained by writing to:

**Los Angeles County Department of Public Works
Hydraulic/Water Conservation Division
P.O. Box 1460
Alhambra, CA 91802-1460**

or telephone: **(818) 458-6112**

LOS ANGELES COUNTY

TOPOGRAPHY

The County of Los Angeles covers an area of 4,083 square miles and measures approximately 66 miles in the east - west and 73 miles in the north - south directions.

The terrain within the County can be classified in broad terms as being 25 percent mountainous; 10 percent coastal plain; and 65 percent hills, valleys, or deserts. Relief of the terrain ranges from sea level to a maximum elevation of 10,000 feet. The coastal plain is generally of mild slope and contains relatively few depressions or natural ponding areas. The slopes of main river systems crossing the coastal plain, such as the San Gabriel River, Los Angeles River, and Ballona Creek, range from 4 to 14 feet per mile.

Topography in the mountainous area is generally rugged with deep, V-shaped canyons separated by sharp dividing ridges. Steepwalled canyons with side slopes of 70 percent or more are common. The gradient of principal canyons in the San Gabriel Mountains ranges from 150 to 850 feet per mile. Mountain ranges are aligned in a general east-west direction with the major range being the San Gabriel Mountains. The majority of mountain ridges lie below Elevation 5,000 feet. The total area above this level is approximately 210 square miles.

GEOLOGY - SOILS

Igneous, sedimentary, and metamorphic rock groups are all represented within the County. The San Gabriel Mountains and Verdugo Hills are composed primarily of highly fractured igneous rock, with large areas of granitic rock formation being exposed above soils that are coarse and porous. Faulting and deep weathering have produced porous zones in the rock formation; however, rock masses have produced a comparatively shallow soil mantle due to the steepness of slopes which accelerates erosion of the fine material.

LAND USE

The principal vegetative cover of upper mountain areas consists of various species of brush and shrubs known as chaparral. Most trees found on mountain slopes are oak, with alder, willow, and sycamore found along streambeds at lower elevations. Pine, cedar, and juniper are found in ravines at higher elevations and along high mountain summits.

The chaparral is extremely flammable, and extensive burns of the mountain vegetation frequently occur during dry, low-humidity weather accompanied by high winds. Chaparral has the ability to sprout following fire and grows rapidly to re-establish the watershed cover within a period of 5 to 10 years.

Grasses are the principal natural vegetation on the hills. Much of the hill land and nearly all of the valley land in the densely populated portion of the County south of the San Gabriel Mountains has been converted to urban and suburban use. Development of the

Santa Clarita Valley and desert areas to the north of the San Gabriel Mountains is sparse at present but is proceeding rapidly.

Other mountains and hilly reaches are composed primarily of folded and faulted sedimentary rock, including shale, sandstone, and conglomerate. Residual soils in these areas are shallow and are generally less pervious than those of the San Gabriel Mountain range.

Valley and desert soils are alluvial and vary from coarse sand and gravel near canyon mouths to silty clay and gravel or clay in lower valleys and the coastal plain. The alluvial fill has been built up by repeated deposition of debris to depths as great as 2,000 feet in places. This fill is quite porous in areas of relatively low clay content. Impervious layers and irregularities in the underlying bedrock divide the alluvium into several County groundwater basins. Valley soils are generally well drained but there are a few areas having perched water.

CLIMATE

The climate within the County varies between subtropical on the Pacific Ocean side of the San Gabriel Mountain range to arid in the Mojave Desert. Nearly all precipitation occurs during the months of December through March. Precipitation during summer months is infrequent, and rainless periods of several months are common. Snowfall at elevations above 5,000 feet is frequently experienced during the winter storms, but the snow melts rapidly except on higher peaks and the northern slopes. Snow is rarely experienced on the coastal plain.

January and July are the coldest and warmest months of the year, respectively. At Los Angeles, the 30-year average daily minimum temperature for January is 48 degrees above zero. The average daily maximum temperature for July is 84 degrees. At Mount Wilson (Elevation 5,850 feet), the 30-year average daily minimum temperature for January is 35 degrees above zero and the average daily maximum temperature for July is 80 degrees.

HYDROMETEOROLOGIC CHARACTERISTICS

Coastal and Mountain Areas

Precipitation in the Los Angeles area occurs primarily in the form of winter orographic rainfall associated with extratropical cyclones of North Pacific origin. Major storms consist of one or more frontal systems and occasionally last four days or longer. Air masses and frontal systems associated with major storms commonly extend for 500 to 1,000 miles in length and produce rainfall simultaneously throughout the County. Major storms approach Southern California from the west or southwest with southerly winds which continue until frontal passage. The mountain ranges lie directly across the path of the inflow of warm, moist air, and orographic effects greatly intensify precipitation.

The effects of snowmelt upon flood runoff is of significance in the few cases when warm

spring rains from southerly storms fall on a snowpack. During major storms, temperatures throughout the County may remain above freezing. Average individual storm rainfall amounts and intensities conform to a fairly definite aerial pattern which reflects general effects of topographic differences.

Desert Areas

Summer convective rainfall is principally experienced in the upper San Gabriel Mountains and the Mojave Desert regions. In many desert areas, the most serious flooding occurs as a result of summer convective storms.

RUNOFF CHARACTERISTICS

Mountain Areas

In mountain areas, the steep canyon slopes and channel gradients promote a rapid concentration of storm runoff quantities. Depression storage and detention storage effects are minor in the rugged terrain. Soil moisture during a storm has a pronounced effect on runoff from the porous soils supporting a good growth of deeprooted vegetation such as chaparral. Soil moisture deficiency is greatest at the beginning of a rainy season, having been depleted by the evapotranspiration process during the dry summer months. Precipitation during periods of soil moisture deficiency is nearly entirely absorbed by soils, and except for periods of extremely intense rainfall, significant runoff does not occur until soils are wetted to field moisture capacity. Due to high infiltration rates and porosity of mountain soils, runoff occurs primarily as subsurface flow or interflow rather than as direct runoff. Spring or base flow is essentially limited to portions of the San Gabriel Mountain range. Consequently, most streams in the County are intermittent.

Runoff from a mountain watershed recently denuded by fire exceeds that for the unburned state due to greatly increased quantities of inorganic debris present in the flow and increased direct runoff resulting from lowered infiltration rates. Debris production from a major storm has amounted to as much as 223,000 cubic yards per square mile of watershed. Boulders up to eight feet in diameter have been deposited in valley areas a considerable distance from their source.

Debris quantities equal in volume to storm runoff, or in other words 100 percent bulking of runoff from a major storm, have been recorded. Where debris-laden flow traverses an alluvial fill unconfined by flood control works, flood discharges follow an unpredictable path across the debris cone formed at the canyon mouth.

Hill and Valley Areas

In hill areas, runoff concentrates rapidly from the generally steep slopes; however, runoff rates from undeveloped hill areas are normally smaller than those from mountain areas of the same size. In those hill areas which have been developed for residential use, concentration times become considerably decreased due to drainage improvement, and

runoff volumes and rates become increased due to increased imperviousness. On the other hand, erosion is controlled and debris is practically eliminated from storm flows. Debris production rates from undeveloped hill areas are normally smaller than those from mountain areas of the same size.

In highly developed valley areas, local runoff volumes have increased as the soil surface has become covered by impervious materials. Peak runoff rates for valley areas have also increased due to elimination of natural ponding areas and improved hydraulic efficiency of water carriers such as streets and storm drain systems.

FLOOD CONTROL AND WATER CONSERVATION

FLOODS. . AN OLD STORY

Floods in Los Angeles County have been recorded as far back as the days of the Mission Padres. For centuries waters have swept out of the San Gabriel Mountains causing extensive property damage and taking a great toll of lives.

Such a flood occurred in 1914 causing over \$10 million in property damage and taking many lives. As a result, the State legislature in 1915 enacted the statute creating the Los Angeles County Flood Control District. The responsibilities and authority vested in the Flood Control District in 1985 were transferred to, and are now part of the Los Angeles County Department of Public Works.

The Department, under the Flood Control Act, has two tasks. . .control the floods and conserve the water.

CONTROLLING THE WATERS

Successful early bond issues financed construction of the 14 dams which the Department built in the San Gabriel Mountains and foothills to impound storm waters until they could be safely released. Debris basins were constructed to trap eroded materials which had caused terrible damage in the past. Flood channel improvements were undertaken to confine the waters and convey them safely through the urbanized areas to the ocean.

Department engineers prepared a Comprehensive Plan in the early 1930's which would control flooding and save as much of the water as practicable when fully implemented.

Federal legislation in 1936 brought the United States Army Corps of Engineers into the local flood control picture. Since that time, the two agencies have been jointly pursuing implementation of the Comprehensive Plan. The Department also cooperates with the United States Soil Conservation Service and Forestry Service in erosion control.

CONSERVING THE WATERS

In addition to its flood control program, the Department has the equally important task of conserving as much of the storm and other waste waters as practicable. The use of water conservation facilities in or adjacent to river channels and their tributaries permits water to be percolated into underground reservoirs for later pumping and supply to consumers. These water conservation facilities are located in areas where the underlying soils are composed of porous sands and gravel formations. Some resemble rice paddies, while others are deep basins which were once gravel pits.

The importance of this activity is apparent when it is realized that about 30 to 40 percent of the water used in the County is pumped from ground supplies. The growth of the

County, combined with periodic droughts, seriously depleted these supplies on numerous occasions throughout the history of the County.

Other major conservation efforts by the Department include combatting the serious salt water intrusion into underground fresh water supplies inland from the Pacific Ocean and utilizing imported water and reclaimed waters in groundwater recharge operations.

ORGANIZED TO DO THE JOB

Day-to-day administration of Department affairs is vested in the Director of Public Works who is appointed by and responsible to the Los Angeles County Board of Supervisors. A part of the Department's activities involve the planning, design and construction of flood control and water conservation facilities, and the operation and maintenance of dams, debris basins, spreading grounds, channels, and storm drains.

PRECIPITATION

PRECIPITATION

This section contains annual precipitation data collected by the Department for the period beginning October 1, 1992 and ending September 30, 1993. Although the Department operates and maintains 293 rainfall stations, including 221 standard and 72 automatic gages which record amounts for durations ranging from 5 minutes to 24 hours, only annual amounts for the report period are listed herein. Additional data can be obtained by contacting the custodian of hydrologic records at the location shown in the front of the report.

RAINFALL AMOUNTS

For the year, rainfall recorded at the downtown Los Angeles station (No. 716) reached 30.89 inches, or 199 percent of the long-term average of 15.51 inches. The Cogswell Dam station (No. 334B) recorded 77.02 inches for the year which is 238 percent of the long-term average of 32.88 inches. The County received the greatest amount of rainfall during the month of January, with the San Fernando Valley in the vicinity of the Sepulveda Basin being among the hardest-hit areas. The above two stations recorded rainfall of 13.36 inches and 34.0 inches, respectively, during that month.

ALERT SYSTEM (AUTOMATIC LOCAL EVALUATION IN REAL TIME)

The Department of Public Works has installed a state-of-the-art ALERT computer system to monitor meteorological conditions in the County and Southern California in real time, i.e., as they occur. The system includes a network of field sensors that monitor precipitation amounts, river stages, and reservoir levels.

During the report period, the Department has continued to install and expand its ALERT System. The Department's ALERT system is also now automatically receiving rainfall data from the Corps of Engineers' Los Angeles Telemetry System.

COOPERATION

The cooperation of observers in furnishing rainfall data to the Department as a public service is appreciated. The effort of the many agencies and individuals who have so freely cooperated with us in the collection of this data have resulted in the large number of complete records for the period covered by this report.

**LOS ANGELES COUNTY RAINFALL INDICES
USING SELECTED STATIONS FOR THE PERIOD
OCTOBER 1, 1992 THROUGH SEPTEMBER 30, 1993**

	PERCENT OF AREA	SEASONAL NORMAL PRECIP. (Inches)	TOTAL PRECIP. (Inches)	PERCENT OF SEASONAL NORMAL	TOTAL PRECIP. LAST YR. (Inches)
A. COSTAL PLAIN	14.10	13.71	26.27	192	17.80
B. SAN FERNANDO VALLEY	7.90	17.62	35.96	204	30.56
C. SAN GABRIEL VALLEY	7.50	17.64	35.56	202	20.40
D. SAN GABRIEL MTS.	13.40	27.50	58.76	214	37.67
E. LITTLE ROCK, BIG ROCK	4.50	18.61	37.18	200	24.94
F. SANTA MONICA MTS.	5.70	19.96	38.33	192	31.56
G. SANTA CLARA	18.90	16.64	34.61	208	27.56
H. DESERT	28.00	7.83	19.89	254	14.79
COUNTY	100.00	15.65	33.05	211	23.77
LOS ANGELES (STATION #716)		15.51	30.89	199	23.26
COGSWELL DAM (STATION #334B)		32.88	77.02	234	52.35

MAX., MIN. & NORMAL CURVES

LOS ANGELES (STATION #716)
SEASONAL NORMAL PRECIPITATION - 15.51"

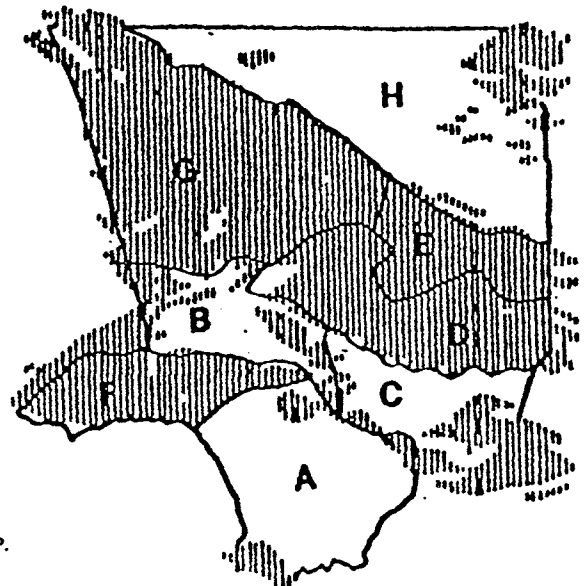
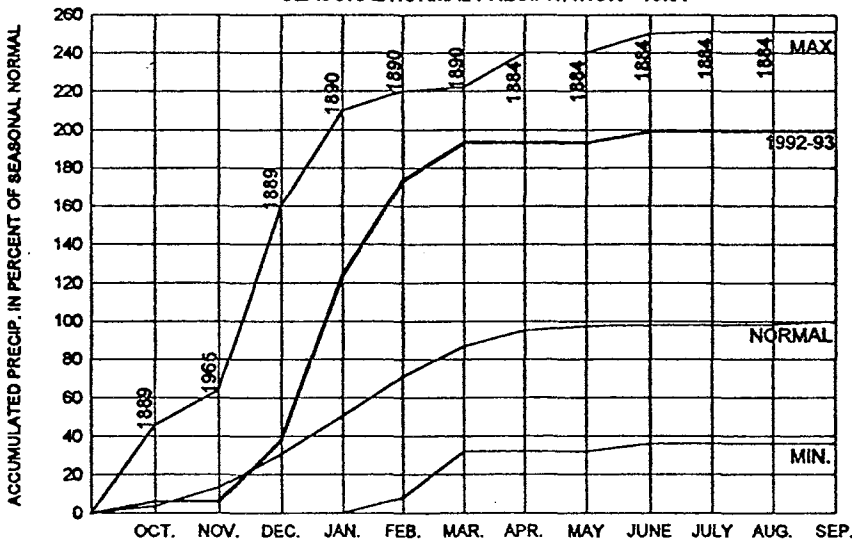

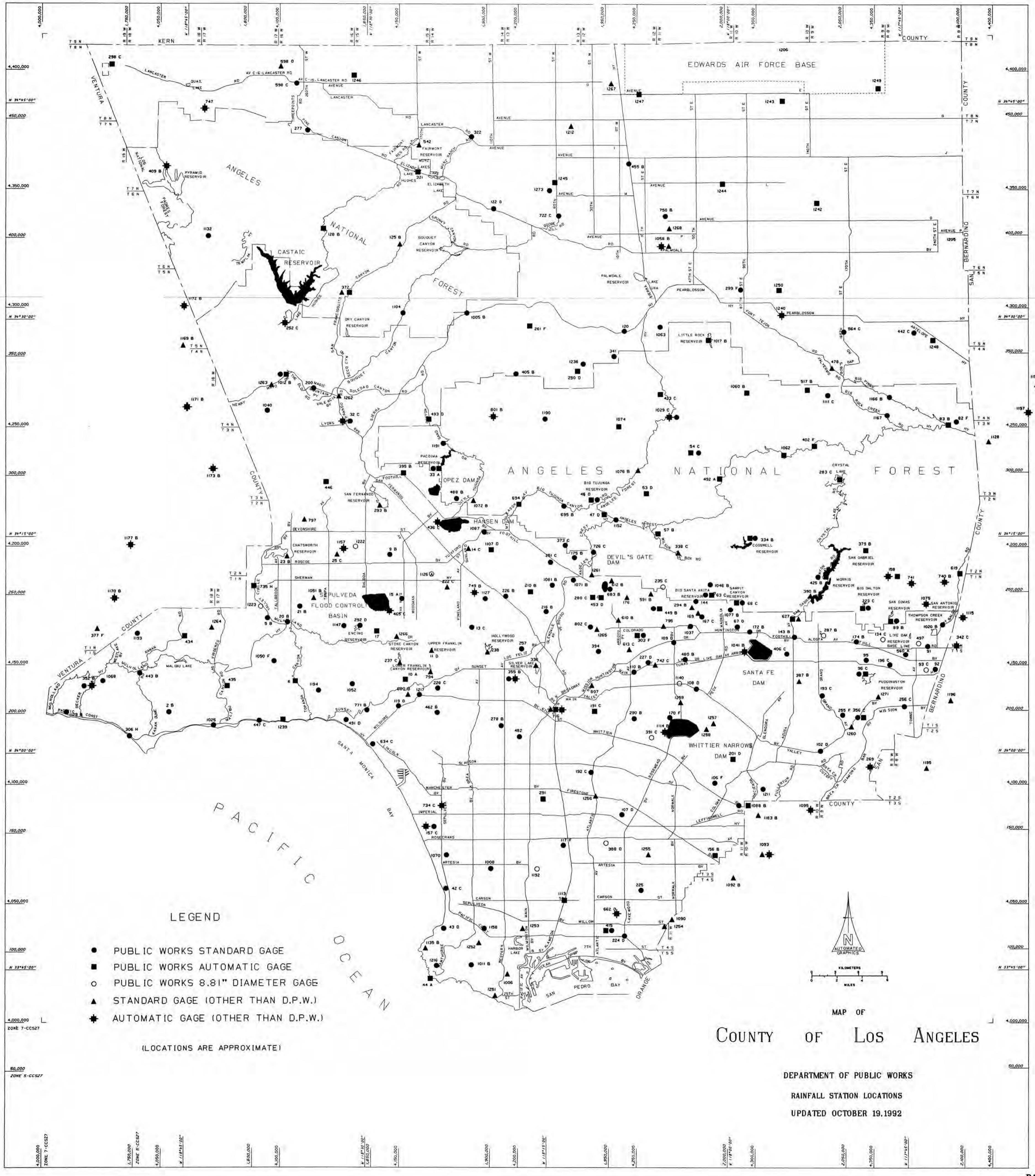

LEGEND

- PUBLIC WORKS STANDARD GAGE
- PUBLIC WORKS AUTOMATIC GAGE
- PUBLIC WORKS 8.81" DIAMETER GAGE
- ▲ STANDARD GAGE (OTHER THAN D.P.W.)
- ✱ AUTOMATIC GAGE (OTHER THAN D.P.W.)

(LOCATIONS ARE APPROXIMATE)

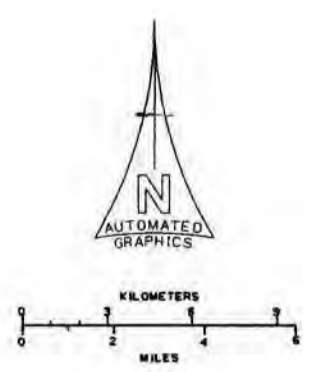

MAP OF
COUNTY OF LOS ANGELES

DEPARTMENT OF PUBLIC WORKS
RAINFALL STATION LOCATIONS
UPDATED OCTOBER 19, 1992

4,000,000 ZONE 7-CC527
3,750,000 ZONE 5-CC527
3,500,000
3,250,000
3,000,000
2,750,000
2,500,000
2,250,000
2,000,000
1,750,000
1,500,000
1,250,000
1,000,000
750,000
500,000
250,000
0

ACTIVE RAINFALL STATIONS 1992-1993

STATION NO.	STATION NAME	TYPE OF GAGE	THOMAS		NORTH LATITUDE	WEST LONGITUDE	GAGE ELEV. (feet)	SEASONAL TOTAL (inches)
			GUIDE PAGE					
2B	ESCONDIDO CANYON	S	112 E3		34-02-55	118-46-25	1050	32.00*
5B	CALABASAS	S	100 F3		34-09-24	118-38-14	924	36.18
6	TOPANGA PATROL STATION	A	109 C5		34-05-03	118-35-57	745	48.60
9B	SEPULVEDA AND RAYEN	S	8 C6		34-13-52	118-28-04	828	35.21
10A	BEL AIR HOTEL	A	32 E5		34-05-11	118-26-45	540	42.20*
11D	UPPER FRANKLIN CYN RES.	SP	33 B1		34-07-10	118-24-35	867	32.62
13C	NORTH HOLLYWOOD-LAKESIDE	S	23 F4		34-08-46	118-21-13	550	40.22
14C	ROSCOE-MERRILL	S	9 F5		34-14-19	118-21-32	1050	35.82
15A	VAN NUYS	S	15 D6		34-10-48	118-27-03	695	36.92
17	SEPULVEDA CYN AT MULHOLLAND	A	22 A5		34-07-51	118-29-26	1425	39.00*
20B	GIRARD RESERVOIR	S	13 B3		34-09-07	118-36-36	986	38.21
21B	WOODLAND HILLS	S	13 C1		34-10-14	118-35-33	875	32.56
23B	CHATSWORTH RESERVOIR	SP AP	6 A6		34-13-44	118-37-18	900	29.12
25C	NORTHRIDGE-L.A.D.W.P.	SP	7 B6		34-13-52	118-32-28	810	32.12
32C	NEWHALL-SOLEDAD DIV. HDQTRS	AP S	127 C3		34-23-07	118-31-54	1243	34.92
33A	PACOIMA DAM	S A	128 F9		34-19-48	118-23-59	1500	37.77
42C	REDONDO BEACH-CITY HALL	S	67 D3		33-50-43	118-23-20	70	22.24
43D	PALOS VERDES ESTATES	S	72 C2		33-47-58	118-23-29	216	24.26
44A	POINT VICENTE LIGHTHOUSE	A	77 B3		33-44-30	118-24-38	125	20.40
46D	BIG TUJUNGA DAM	S A	M C2		34-17-40	118-11-14	2315	58.03
47D	CLEAR CREEK-CITY SCHOOL	A	M D3		34-16-38	118-10-12	3150	65.80
53D	COLBY'S	A	M F2		34-18-05	118-06-39	3620	52.60
54C	LOOMIS RANCH-ALDER CREEK	S A	(197)		34-20-55	118-02-54	4325	46.00*
57B	CAMP HI HILL (OPIDS)	A	M F3		34-15-18	118-05-41	4250	86.10
63C	SANTA ANITA DAM	S A	20A F2		34-11-03	118-01-12	1400	53.58
67G	MONROVIA-MOUNTAIN AVENUE	S	29 C4		34-08-46	117-59-05	602	40.77
68C	SAWPIT DAM	S A	20B C6		34-10-30	117-59-07	1375	54.18
82F	TABLE MOUNTAIN	S	(201)		34-22-56	117-40-39	7420	61.92
83B	BIG PINES RECREATION PARK	A	(201)		34-22-44	117-41-20	6860	47.90
89B	SAN DIMAS DAM	S A	95A C3		34-09-10	117-46-17	1350	52.02
91	CLAREMONT-INDIAN HILL	S	91 B1		34-07-22	117-43-11	1403	43.80
92	CLAREMONT-POMONA COLLEGE	S	91 C4		34-05-48	117-42-33	1185	41.50*
93C	CLAREMONT-POLICE STATION	8.81	91 B4		34-05-45	117-43-18	1170	38.68
95	SAN DIMAS-FIRE WARDEN	S	89 F3		34-06-26	117-48-19	955	39.66
96C	PUDDINGSTONE DAM	S A	89 F4		34-05-31	117-48-24	1030	40.08
102D	WALNUT-N.I. INDUSTRIES	S	97 B2		34-00-11	117-52-10	500	30.85
106F	WHITTIER CITY YARD	S	55 D4		33-58-57	118-02-50	300	29.36
107D	DOWNEY-FIRE DEPARTMENT	S	60 A5		33-55-48	118-08-47	110	26.55
108D	EL MONTE FIRE STATION	S	38 D6		34-04-30	118-02-30	275	34.55
109D	WEST ARCADIA	S	28 A6		34-07-42	118-04-22	547	37.58

ACTIVE RAINFALL STATIONS 1992-1993

STATION NO.	STATION NAME	TYPE OF GAGE	THOMAS GUIDE PAGE	NORTH LATITUDE	WEST LONGITUDE	GAGE ELEV. (feet)	SEASONAL TOTAL (inches)
110B	ALHAMBRA	S	37 B3	34-05-40	118-07-41	533	34.56
117F	COMPTON FIRE STATION	S	64 F3	33-53-42	118-13-34	78	29.40*
119G	SAWTELLE-SOLDIERS HOME	S	41 D2	34-03-21	118-27-20	345	38.00*
120	VINCENT PATROL STATION	S	183 A9	34-29-17	118-08-27	3135	20.30
122G	LEONA VALLEY-RACKETT RANCH	S	171 G3	34-37-52	118-19-22	3300	26.00*
125B	SAN FRANCISQUITO CYN P.H. 1	SP	(169)	34-35-25	118-27-15	2105	35.00
128B	ELIZABETH LAKE	A	(168)	34-36-28	118-33-40	2075	42.00
134C	PUDDINGSTONE DIVERSION	8.81	95A C5	34-07-52	117-46-55	1160	43.54
143B	AZUSA-CITY PARK	S	86 D5	34-08-03	117-54-17	610	42.60
144	SIERRA MADRE DAM	S	20A D3	34-10-34	118-02-32	1100	52.79
156B	LA MIRADA-STANDARD OIL CO.	A	83 A4	33-52-59	118-01-00	75	26.10
157C	EL SEGUNDO-CHEVRON OIL CO.	AP S	56 A6	33-54-57	118-25-05	150	22.00*
158	TANBARK FLATS	AP A	P D5	34-12-20	117-45-40	2750	68.00*
167C	ARCADIA PUMPING PLANT #1	S	28 E2	34-09-31	118-02-02	611	43.41
169	SIERRA MADRE PUMPING PLANT	SP	28 D2	34-09-47	118-02-21	700	45.88
170F	POTRERO HEIGHTS	S	47 A4	34-02-32	118-04-44	285	35.23
172B	DUARTE	S	29 E4	34-08-26	117-58-02	548	39.55
174B	GLENDORA	S	87 E6	34-07-43	117-49-08	930	42.15
175B	LA CANADA IRRIGATION DIS.	S	19 A1	34-13-39	118-12-40	2020	49.68
176	ALTADENA-RUBIO CANYON	SP	20 B6	34-10-55	118-08-15	1125	41.89
191C	L.A.C.D.P.W.-WAREHOUSE	A	45 B1	34-03-48	118-11-58	400	31.00*
192C	BELL-FIRE STATION	8.81	53 C5	33-58-45	118-11-16	145	29.60*
193C	COVINA-NIGG	S	89 A5	34-04-55	117-52-25	575	34.84
196C	LA VERNE-FIRE STATION	S	90 D3	34-06-06	117-46-20	1050	42.79
200	SAUGUS-S. C. EDISON CO.	S	123 H8	34-25-21	118-34-26	1096	24.53
201D	HACIENDA HEIGHTS	A	85 C3	33-59-40	117-59-28	875	36.30
210C	BRAND PARK	A	18 B5	34-11-18	118-16-20	1250	36.50*
216B	GLENDALE-ANDREE	S	25 D2	34-09-54	118-15-01	615	36.50
222C	NORTH HOLLYWOOD P. P.	SP	16 C4	34-11-39	118-23-17	717	34.30*
223C	BIG DALTON DAM	S A	87 F2	34-10-06	117-48-36	1587	53.56
224D	LONG BEACH-ALAMITOS LAND CO.	S	76 B3	33-46-42	118-08-04	45	24.26
225	MONTANA RANCH - LAKEWOOD	S	71 C3	33-50-35	118-07-09	47	24.41
226B	BURBANK-FIRE STATION	S	17 E6	34-10-58	118-18-23	680	34.17
227D	SAN GABRIEL-BRUNINGTON-ORTON	S	37 D2	34-06-18	118-06-32	472	36.90
228C	BEVERLY HILLS CITY HALL	AP S	33 C6	34-06-00	118-23-40	245	37.54
235C	HENNIGER FLATS	A 8.81	20 F4	34-11-38	118-05-17	2550	66.55
237C	STONE CANYON RESERVOIR	SP	32 D2	34-06-21	118-27-13	865	41.27
238	HOLLYWOOD DAM	SP	34 C1	34-07-04	118-19-55	750	33.71
250D	ACTON CAMP	A	189 E5	34-27-02	118-11-55	2625	24.60
251C	LA CRESCENTA	S	18 D1	34-13-20	118-14-40	1440	47.74

ACTIVE RAINFALL STATIONS 1992-1993

STATION NO.	STATION NAME	TYPE OF GAGE	THOMAS GUIDE PAGE	NORTH LATITUDE	WEST LONGITUDE	GAGE ELEV. (feet)	SEASONAL TOTAL (inches)
252C	CASTAIC DAM	SP AP	(178)	34-29-53	118-36-53	1150	30.63
255F	MT. SAN ANTONIO COLLEGE	S	93 D4	34-02-41	117-50-19	720	32.36
256C	POMONA-FIRE STATION	S	94 E3	34-03-16	117-45-10	844	36.25
257	GRIFFITH PARK NURSERY	S	35 A1	34-07-18	118-17-04	850	34.90*
261F	ACTON-ESCONDIDO CANYON	A	181 H9	34-29-42	118-16-22	2960	24.80
269D	DIAMOND BAR FIRE STATION	SP AP	97 F2	33-59-50	117-48-55	870	40.78
277	SAWMILL MOUNTAIN	S	(155)	34-43-15	118-35-00	3700	45.54
278B	L.A. CLARK MEMORIAL LIBRARY	S	43 D5	34-02-00	118-18-46	203	30.00*
280C	FLINTRIDGE-SACRED HEART	A	19 D6	34-10-54	118-11-08	1600	43.90
283C	CRYSTAL LAKE-EAST PINE FLAT	A	P B1	34-19-02	117-50-28	5370	82.20
287B	GLENDORA-CITY HALL	8.81	87 B5	34-08-09	117-51-52	785	45.67
289	LAGUNA-BELL-S.C.E. CO.	SP	54 A5	33-58-37	118-08-48	140	28.70*
290B	MONTEREY PARK-FIRE STATION	S	46 B4	34-02-27	118-07-42	305	37.41
291	LOS ANGELES-96th AND CENTRAL	A	58 C3	33-56-56	118-15-17	121	27.70*
292D	ENCINO RESERVOIR	S A	21 D3	34-08-56	118-30-57	1075	39.42
293B	LAKE LOS ANGELES	SP	2 A4	34-17-18	118-28-54	1150	35.41
294B	SIERRA MADRE-MIRA MONTE P.P.	SP	28 C1	34-10-11	118-02-51	985	50.04
298C	GORMAN - SHERIFF	A	(141)	34-47-47	118-51-27	3835	25.00
299F	LITTLE ROCK - SCHWAB	S	184 F5	34-32-12	117-58-43	2800	15.29
303F	PASADENA - CALTECH	A	27 C5	34-08-14	118-07-25	800	41.40*
306H	ZUMA BEACH	S	111 F6	34-01-15	118-49-42	15	22.74
321	PINE CANYON PATROL STATION	A	157 D7	34-40-24	118-25-45	3286	36.00*
322	MUNZ VALLEY RANCH	S	158 A2	34-42-50	118-21-15	2600	27.90
334B	COGSWELL DAM	S A	N D4	34-14-37	117-57-35	2300	77.02
336	SILVER LAKE RESERVOIR	SP	35 B3	34-06-08	118-15-54	445	29.34
338C	MT. WILSON-OBSERVATORY	SP	20A C1	34-14-07	118-04-28	5709	64.78
341	ALISO CANYON-BLUM RANCH	S	189 J4	34-27-33	118-09-20	2900	23.33*
342C	UPLAND-CHAPPEL	AP	96 E6	34-07-33	117-40-52	1610	41.57
352B	LECHUZA PATROL STATION	AP S	105 B6	34-04-38	118-52-47	1620	32.20
355B	LOS ANGELES CITY COLLEGE	AP S	34 F4	34-05-14	118-17-28	310	34.24
356C	SPADRA-LANTERMAN HOSPITAL	S A	93 F4	34-02-31	117-48-35	690	35.18
372	SAN FRANCISQUITO P. H. NO.2	SP A	(179)	34-32-02	118-31-27	1580	36.75
373C	BRIGGS TERRACE	S A	11 F5	34-14-17	118-13-27	2200	54.54
377F	LAKE SHERWOOD ESTATES	SP AP	102A C4	34-08-26	118-52-31	960	35.29
379B	SAN GABRIEL-EAST FORK	A	P C4	34-14-09	117-48-18	1600	58.10*
387B	COVINA CITY YARD	SP	88 E5	34-05-02	117-53-57	508	32.33
388D	PARAMOUNT-COUNTY FIRE DEPT.	8.81	65 E3	33-53-50	118-10-02	80	34.19
390B	MORRIS DAM	SP	P A6	34-10-53	117-52-43	1210	54.00
391C	MONTEBELLO-FIRE DEPARTMENT	8.81	54 E1	34-01-08	118-06-15	250	32.51
394	HIGHLAND PARK	S	36 D1	34-07-06	118-10-39	620	36.31

ACTIVE RAINFALL STATIONS 1992-1993

STATION NO.	STATION NAME	TYPE OF GAGE	THOMAS GUIDE PAGE	NORTH LATITUDE	WEST LONGITUDE	GAGE ELEV. (feet)	SEASONAL TOTAL (inches)
395B	OLIVE VIEW SANITARIUM	A	2 D1	34-19-29	118-26-55	1425	41.50
402F	CEDAR SPRINGS	A	(199)	34-21-21	117-52-34	6780	54.00*
405B	SOLEDAD CANYON	S	188 F6	34-26-23	118-17-33	2150	33.18
406C	WEST AZUSA	S	88 C2	34-06-53	117-54-56	505	35.42
409B	PYRAMID RESERVOIR	SP AP	(154)	34-40-34	118-46-47	2505	32.66
415	SIGNAL HILL-CITY HALL	S A	75 E2	33-47-49	118-10-03	140	22.94
423C	ANGELES FOREST-ALISO CYN	A	(190A)	34-24-57	118-05-26	3920	40.90*
425B	SAN GABRIEL DAM	S A	P A5	34-12-19	117-51-38	1481	64.58
434	AGOURA	A	100A A5	34-08-08	118-45-08	800	32.70
435	MONTE NIDO	A	108 A6	34-04-41	118-41-35	600	43.30
436C	HANSEN DAM	AP	9 C2	34-16-08	118-23-59	1110	34.40
442C	MESCAL CREEK	S	(194)	34-29-05	117-44-10	3570	15.40
443B	LATIGO CANYON-BEACH RANCH	S	106 B4	34-05-35	118-48-52	1700	41.94
446	ALISO CANYON-OAT MOUNTAIN	A	1 A2	34-18-53	118-33-25	2367	33.10*
447C	CARBON CANYON	S	114 E4	34-02-18	118-38-56	50	28.03
449B	EATON WASH DAM	S A	27 E1	34-10-06	118-05-33	880	40.98
453D	DEVILS GATE DAM	A	19 D6	34-10-53	118-10-27	980	42.00*
455B	LANCASTER-HWY MAINTENANCE	S	160 B6	34-40-57	118-08-02	2395	18.05
462B	HILLCREST COUNTRY CLUB	S	42 B3	34-02-54	118-24-06	185	36.62
465C	SEPULVEDA DAM	AP	22 B1	34-10-06	118-28-11	683	35.00
478	VALYERMO-U.S.F.S.	SP	192 H5	34-26-44	117-51-10	3710	23.33*
480B	TEMPLE CITY FIRE STATION	S	38 C2	34-06-31	118-03-25	404	33.73
482	LOS ANGELES-U.S.C.	S	43 F6	34-01-14	118-17-15	208	28.22
488B	KAGEL CANYON PATROL STATION	S	3 E4	34-17-45	118-22-30	1450	36.90
491D	PACIFIC PALISADES	S	40 C4	34-02-22	118-31-43	293	32.01
492A	CHILAO-HWY MAINTENANCE STA.	A	N C1	34-19-05	118-00-30	5275	55.30*
493D	SAND CANYON-MACMILLAN RANCH	A	128 D3	34-23-17	118-24-50	1805	50.00*
497	CLAREMONT-SLAUGHTER	8.81	91 A1	34-07-35	117-43-55	1350	44.43
517B	LEWIS RANCH	A	(192A)	34-25-12	117-53-11	4615	33.30*
542	FAIRMONT	SP	(145)	34-42-15	118-25-40	3050	35.17
560A	LA VERNE HEIGHTS	S	90 E2	34-06-48	117-45-02	1210	44.19
564C	LLANO	S	185 J9	34-29-13	117-50-02	3390	13.58
591B	SANTA ANITA RESERVOIR	SP	20 E5	34-11-08	118-06-16	1205	50.59
598C	NEENACH-ERSTAD	S	(143)	34-46-28	118-35-55	3062	27.02
598D	NEENACH-CHECK 43-D.W.R.	SP	(143)	34-47-40	118-37-15	2965	21.29
610B	PASADENA-CITY HALL	SP	27 A4	34-08-54	118-08-36	864	38.68
612B	PASADENA-CHLORINE PLANT	SP	19 E3	34-12-04	118-09-49	1160	47.35
613C	PASADENA FIRE STATION	SP	27 B5	34-07-15	118-08-05	779	37.91
619	SAN ANTONIO CYN-SIERRA P. H.	A	P F5	34-12-29	117-40-26	3110	68.21*
627	SAN GABRIEL CANYON-P. H.	SP A	86 D3	34-09-20	117-54-28	744	48.90

ACTIVE RAINFALL STATIONS 1992-1993

STATION NO.	STATION NAME	TYPE OF GAGE	THOMAS GUIDE PAGE	NORTH LATITUDE	WEST LONGITUDE	GAGE ELEV. (feet)	SEASONAL TOTAL (inches)
634C	SANTA MONICA	S	49 A1	34-00-43	118-29-27	94	22.29
662D	LONG BEACH AIRPORT	SP	71 A6	33-49-00	118-09-00	34	22.98
680B	WESTWOOD (U.C.L.A.)	SP	41 E1	34-04-10	118-26-30	430	37.89
683B	SUNSET RIDGE	S A	19 E4	34-12-53	118-08-47	2110	49.31
694G	BIG TUJUNGA CANYON-CAMP 15	A	M D6	34-17-22	118-17-17	1525	39.50
695B	TUJUNGA CANYON-VOGEL FLAT	S	M B2	34-17-12	118-13-32	1850	62.43
716	LOS ANGELES-DUCOMMUN ST.	SP A AP	44 E3	34-03-09	118-14-13	306	30.89
722C	BELLEVUE	S	171 B3	34-37-23	118-13-55	2880	20.81
726C	ANGELES CREST GUARD STATION	S	M D4	34-14-01	118-11-04	2300	61.06
734C	L. A. INTERNATIONAL AIRPORT	SP AP	56 C3	33-56-25	118-23-44	105	23.34
735H	BELL CANYON	A	5 D4	34-11-40	118-39-23	895	34.70
740B	SAN DIMAS CANYON-FERN NO.2	AP	P F6	34-11-48	117-41-45	5200	67.33*
741	SAN DIMAS CYN	AP	P E6	34-11-41	117-44-26	2675	66.00*
742C	SAN GABRIEL FIRE DEPARTMENT	SP	37 E3	34-06-11	118-05-56	445	34.18
747	SANDBERG-AIRWAYS STATION	SP AP	(142)	34-44-47	118-43-29	4517	34.93
749B	BURBANK VALLEY PUMP PLANT	SP AP	17 A5	34-11-11	118-20-54	655	34.16
750B	PALMDALE REGIONAL AIRPORT	S	172 F6	34-37-20	118-05-00	2528	17.21
771B	PACIFIC PALISADES-RIVIERA	S	40 F3	34-03-03	118-29-58	315	36.00*
794	LOWER FRANKLIN RESERVOIR	SP	33 B4	34-05-43	118-24-40	585	37.03
795	PASADENA - JOURDAN	SP	27 F4	34-08-52	118-05-14	705	45.18
797	DE SOTO RESERVOIR	SP	6 D1	34-16-17	118-35-12	1127	32.20
801B	MAGIC MOUNTAIN	AP	(195)	34-23-18	118-19-27	4720	59.19
802C	EAGLE ROCK RESERVOIR	SP	26 C4	34-08-47	118-11-20	970	36.93
807	ASCOT RESERVOIR	SP AP	36 C5	34-04-46	118-11-14	620	32.43
1005B	MINT CANYON FIRE STATION	S	(180)	34-30-35	118-21-40	2300	26.32
1006	SAN PEDRO-CITY RESERVOIR	SP A	78 F2	33-44-37	118-17-47	150	22.84
1008	LA FRESA-S.C.E.CO.	S	63 C6	33-52-07	118-19-55	65	24.36*
1011B	PALOS VERDES FIRE STATION	S	78 A1	33-45-25	118-21-11	1275	24.03
1012B	CASTAIC JUNCTION	S A	123 E6	34-26-18	118-36-43	1005	26.76
1017B	LITTLE ROCK CREEK ABOVE DAM	A	(191)	34-28-41	118-01-24	3280	20.40
1020B	PADUA HILLS PATROL STATION	S	96 D4	34-08-52	117-41-55	1800	48.87
1025	MALIBU BEACH-DUNNE	S	113 E5	34-02-00	118-42-42	160	23.23
1029C	TUJUNGA-MILL CREEK SUMMIT	AP S	(197)	34-23-22	118-04-49	4990	43.91
1037	ARCADIA-ARBORETUM	S	28 C4	34-08-48	118-02-59	565	40.63
1040	POTRERO CYN-SUNRAY OIL CO.	S	126 C2	34-23-50	118-38-18	1150	24.29*
1041B	SANTA FE DAM	AP	39 D1	34-07-04	117-58-24	427	36.63
1046B	SANTA ANITA CYN-CHANTRY FLAT	S	20A F1	34-11-46	118-01-20	2175	65.05
1050F	OLD TOPANGA CANYON	S	108 F3	34-06-24	118-37-43	1000	52.70
1051B	CANOGA PARK-PIERCE COLLEGE	SP	12 E5	34-10-51	118-34-23	800	35.73
1052	CAMP JOSEPHO	S	30 D5	34-04-51	118-31-10	660	44.30*

ACTIVE RAINFALL STATIONS 1992-1993

STATION NO.	STATION NAME	TYPE OF GAGE	THOMAS		NORTH LATITUDE	WEST LONGITUDE	GAGE ELEV. (feet)	SEASONAL TOTAL (inches)
			GUIDE PAGE					
1058B	PALMDALE	SP AP	172	E7	34-35-17	118-05-31	2595	17.20
1060B	LITTLE ROCK-SYCAMORE CAMP	A	(191)		34-25-02	117-58-13	4000	38.00*
1062	BUCKHORN FLAT	A	(199)		34-20-44	117-55-08	6760	54.40
1063	SOLEDAD PASS	S	183	E9	34-29-35	118-05-28	3520	22.48
1068	RATTLESNAKE CANYON	S	105	C5	34-05-00	118-51-55	1290	34.00*
1070	MANHATTAN BEACH	S	62	D4	33-53-00	118-23-19	182	22.13
1071B	DESCANSO GARDENS	S	19	B2	34-12-07	118-12-46	1325	43.81
1072B	LITTLE TUJUNGA RANGER STA.	SP A	3	F5	34-17-37	118-21-38	1275	38.83
1074	LITTLE GLEASON	A	(197)		34-22-43	118-08-57	5600	38.00*
1075	UPPER WOLFSKILL	AP	96	B2	34-10-13	117-43-16	3625	58.00*
1076B	MONTE CRISTO RANGER STATION	SP	M	E1	34-19-42	118-07-20	3360	46.06
1077B	MONROVIA-FIVE POINTS	S	29	B1	34-09-58	117-59-37	962	50.39
1081B	GLENDALE-GREGG	SP	18	D4	34-11-45	118-14-30	1350	42.40
1087	GREEN-VERDUGO PUMPING PLANT	S	10	B3	34-15-25	118-20-11	1340	31.52
1088B	LA HABRA HEIGHTS	S A	84	E2	33-56-55	117-57-51	445	30.58
1090	LOS ALAMITOS	SP	81	B6	33-48-35	118-04-35	25	19.67
1092B	BUENA PARK	3" P	OC10	C1	33-51-28	117-59-29	80	27.55
1093	FULLERTON AIRPORT	SP AP	83	D5	33-52-23	117-58-24	100	27.27
1095	ORANGE COUNTY RESERVOIR	SP AP	OC 2	F4	33-56-07	117-52-58	660	31.47
1104	BOUQUET CANYON AT TEXAS CYN	S	(180)		34-30-35	118-27-00	1760	29.00*
1107D	LA TUNA DEBRIS BASIN	A	10	C5	34-14-13	118-19-37	1160	35.40*
1111C	DEVILS PUNCHBOWL	S	(192A)		34-24-48	117-51-25	4760	38.91
1113	DOMINGUEZ WATER CO.	A	69	F4	33-49-54	118-13-30	30	24.30
1114B	WHITTIER NARROWS DAM	AP	47	A6	34-01-29	118-05-02	239	31.88
1115	SAN ANTONIO DAM	AP SP	96	F3	34-09-24	117-40-20	2120	53.06
1126A	LOS ANGELES-EAST VALLEY	8.81	16	B3	34-12-30	118-24-35	780	34.52
1127	WEST BURBANK	S	17	B6	34-10-47	118-20-07	615	35.00*
1128	WRIGHTWOOD FIRE DEPARTMENT	SP	S.B.CO.		34-21-34	117-37-57	5960	39.90
1129B	NICHOLAS CANYON	S	110	D3	34-02-52	118-54-57	340	22.23
1132	OAK FLAT GUARD STATION	S	(166)		34-35-56	118-43-15	2800	44.85
1135B	LUNADA BAY	SP	72	A4	33-46-37	118-25-01	250	21.00*
1140	ROSEMEAD	8.81	38	B5	34-04-53	118-03-55	305	32.22
1147	EL CABALLERO COUNTRY CLUB	S	21	C4	34-08-52	118-31-53	1000	44.49
1152	CLEAR CREEK RANGER STATION	S	M	D3	34-16-15	118-09-11	3625	70.00*
1157	CAL STATE UNIV. NORTHRIDGE	SP AP	7	C5	34-14-17	118-31-48	890	30.00*
1158	TORRANCE MUNICIPAL AIRPORT	S	73	B2	33-47-59	118-20-08	102	25.08
1166B	MILE HIGH RANCH	S	(193)		34-24-40	117-46-15	5280	32.22
1167	FENNER CANYON	S	(200)		34-23-25	117-46-27	5380	46.00
1169B	PIRU-TEMESCAL GUARD STATION	SP	V.CO.		34-28-22	118-45-21	1150	39.04
1170B	THOUSAND OAKS WEATHER STA.	AP	V.CO.		34-10-44	118-51-01	805	30.40

ACTIVE RAINFALL STATIONS 1992-1993

STATION NO.	STATION NAME	TYPE OF GAGE	THOMAS GUIDE PAGE	NORTH LATITUDE	WEST LONGITUDE	GAGE ELEV. (feet)	SEASONAL TOTAL (inches)
1171B	CAMULOS RANCH	SP AP	V.CO.	34-24-22	118-45-21	725	32.60
1172B	PIRU CANYON ABOVE PIRU LAKE	AP	(177)	34-30-48	118-45-24	1120	39.54
1173B	TAPO CANYON	AP	V.CO.	34-19-54	118-42-39	1525	33.10
1177B	BARD RESERVOIR	AP	V.CO.	34-14-32	118-49-41	1010	27.30
1183B	LA HABRA FIRE STATION	3 ^{HP}	84 F4	33-55-53	117-57-17	315	30.60*
1190	PACOIMA CYN-NORTH FORK	S	(195)	34-23-17	118-15-06	4180	46.00*
1191	BEAR DIVIDE	S	128 F6	34-21-35	118-23-37	2700	48.10
1192	CARSON FIRE STATION	8.81	64 C6	33-52-04	118-15-45	92	15.85
1193	WESTLAKE VILLAGE	S	102 A5	34-08-19	118-49-05	885	31.92
1194	SANTA YNEZ RESERVOIR	S	109 F6	34-04-23	118-33-59	735	37.07
1195	CHINO FIRE STATION NO. 2	SP	S.B.CO.	33-59-00	117-43-20	655	30.97
1196	MONTCLAIR FIRE DEPARTMENT	SP	95 E2	34-03-41	117-41-16	965	37.22
1197	CAJON WEST SUMMIT	SP	S.B.CO.	34-23-30	117-34-35	4838	30.00*
1198	PHELAN FIRE CONTROL	SP	S.B.CO.	34-25-30	117-34-00	4160	19.82
1211	HACIENDA GOLF CLUB	S	98A A1	33-57-40	117-56-57	750	32.00*
1212	LANCASTER FSS/FAA	SP	147 C9	34-44-00	118-13-00	2340	19.49
1216	RANCHO PALOS VERDES	S	77 C1	33-45-10	118-23-32	780	20.36
1217	LOS ANGELES COUNTRY CLUB	S	42 A1	34-04-10	118-25-17	380	38.44
1222	NORTHRIDGE-GARLAND	8.81	7 E3	34-14-17	118-30-59	911	31.90
1223	WOODLAND HILLS-SHERMAN	8.81	100 E1	34-10-06	118-38-57	1035	31.06
1238	ACTON-MEARNS	S	189 G2	34-27-05	118-12-50	2775	24.00*
1239	MALIBU-BIG ROCK MESA	A	115 A4	34-02-34	118-37-16	725	31.70
1240	PEARBLOSSOM-CALIF.D.W.R.	SP AP	185 B7	34-30-32	117-55-15	3050	15.52
1242	ROCKY BUTTES	A	(162)	34-39-00	117-51-48	2540	11.50*
1243	REDMAN	A	(150)	34-45-52	117-55-30	2360	13.00*
1244	LANCASTER-ROPER	A	161 C6	34-40-27	118-00-37	2450	14.00*
1245	QUARTZ HILL-HALL	A	159 B7	34-40-28	118-14-40	2395	22.20*
1246	SCOTT RANCH	A	(145)	34-46-59	118-28-10	2710	23.00*
1247	NORTH LANCASTER	A	148 D6	34-45-41	118-07-30	2310	19.50*
1248	MESCAL-SMITH	A	(194)	34-28-03	117-42-40	3810	18.50
1249	RELAY	A	(150)	34-45-43	117-47-55	3140	10.00*
1250	AVEK	A	185 B5	34-32-21	117-55-23	2825	13.50*
1251	PALOS VERDES-WHITES POINT	SP	78 D6	33-42-50	118-19-02	100	16.24
1252	PALOS VERDES LANDFILL	SP	73 A4	33-45-40	118-20-03	400	24.33*
1253	CARSON-COUNTY SANITATION	SP	74 A2	33-48-07	118-16-58	40	21.96
1254	LONG BEACH RECLAMATION PLANT	SP	76 F1	33-48-11	118-05-20	20	22.75
1255	LOS COYOTES RECLAMATION	SP	66 E4	33-53-05	118-06-24	70	29.44
1256	SOUTH GATE TRANSFER STATION	SP	59 E3	33-56-40	118-09-56	100	28.67*
1257	SAN JOSE CREEK RECLAMATION	SP	47 F4	34-01-55	118-01-16	275	30.86*
1258	PUENTE HILLS LANDFILL	SP	47 E5	34-01-35	118-01-49	300	29.52

ACTIVE RAINFALL STATIONS 1992-1993

STATION NO.	STATION NAME	TYPE OF GAGE	THOMAS		NORTH LATITUDE	WEST LONGITUDE	GAGE ELEV. (feet)	SEASONAL TOTAL (inches)
			GUIDE	PAGE				
1259	WHITTIER NARROWS RECLAMATION	SP	47	B1	34-03-59	118-03-54	225	32.00*
1260	SPADRA LANDFILL	SP	93	E4	34-02-36	117-49-50	700	32.25
1261	LA CANADA RECLAMATION PLANT	SP	19	D2	34-13-00	118-11-14	1800	49.00*
1262	SAUGUS RECLAMATION PLANT	SP	124	B9	34-24-48	118-32-23	1150	26.00*
1263	VALENCIA RECLAMATION PLANT	SP	123	D7	34-25-55	118-37-13	1000	24.58
1264	CALABASAS LANDFILL	SP	100A	E3	34-08-25	118-42-35	800	33.50*
1265	SCHOLL CANYON LANDFILL	SP	26	C4	34-08-38	118-11-07	1000	37.10*
1266	MISSION CANYON LANDFILL	SP	22	B6	34-08-40	118-28-45	1150	38.00*
1267	LANCASTER RECLAMATION PLANT	SP	147	H4	34-46-38	118-09-11	2302	22.32
1268	PALMDALE RECLAMATION PLANT	SP	172	G6	34-35-30	118-05-10	2565	16.50*
1271	POMONA WASTE RECLAMATION	SP	94	B3	34-03-18	117-47-34	786	35.50*

LEGEND:

- S Standard 8 Inch Non-recording Gage Owned By L.A. County Public Works
 8.81 8.81 Inch Diameter Non-recording Gage Owned By L.A. County Public Works
 A Automatic Recording Gage Owned By L.A. County Public Works
 SP Standard 8 Inch Diameter Non-recording Gage Owned By Outside Interest
 AP Automatic Recording Gage Owned By Outside Interest
 3" P Standard 3 Inch Gage Owned By Outside Interest
 () Thomas Guide Page
 O.CO. Orange County Thomas Guide Page
 V.CO. Ventura County Thomas Guide Page
 S.B.CO. San Bernardino County Thomas Guide Page
 * Estimated Seasonal Total

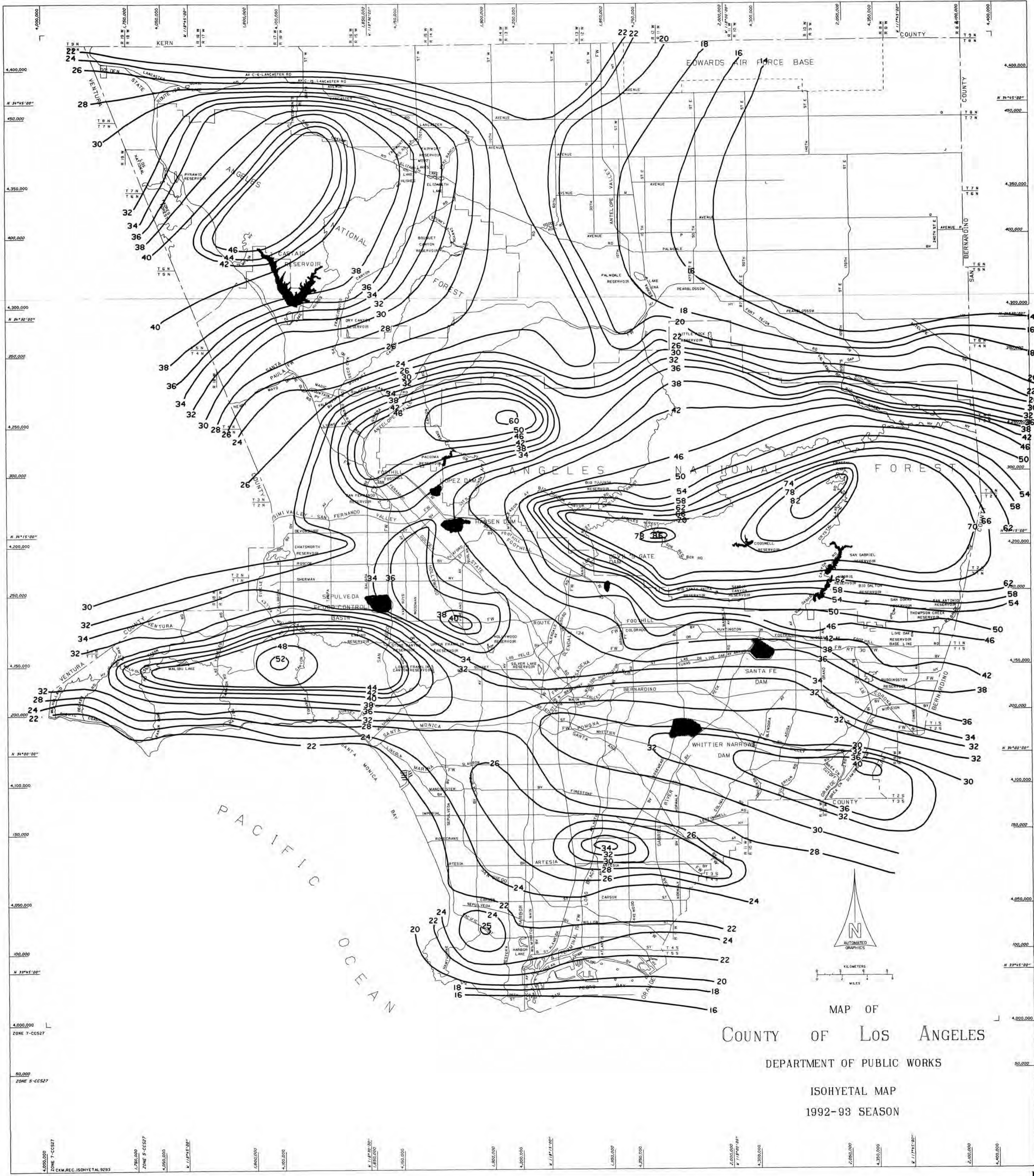

MAP OF
 COUNTY OF LOS ANGELES
 DEPARTMENT OF PUBLIC WORKS
 ISOHYETAL MAP
 1992-93 SEASON

4,000,000
 ZONE 7-CC527
 50,000
 ZONE 5-CC527
 1,750,000
 ZONE 5-CC527
 1,850,000
 1,950,000
 2,050,000
 2,150,000
 2,250,000
 2,350,000
 2,450,000
 2,550,000
 2,650,000
 2,750,000
 2,850,000
 2,950,000
 3,050,000
 3,150,000
 3,250,000
 3,350,000
 3,450,000
 3,550,000
 3,650,000
 3,750,000
 3,850,000
 3,950,000
 4,000,000
 4,050,000
 4,100,000
 4,150,000
 4,200,000
 4,250,000
 4,300,000
 4,350,000
 4,400,000
 4,450,000
 4,500,000
 4,550,000
 4,600,000
 4,650,000
 4,700,000
 4,750,000
 4,800,000
 4,850,000
 4,900,000
 4,950,000
 5,000,000

EVAPORATION

EVAPORATION

Data for 14 active evaporation stations were reported to the Department during the 1992-93 water year. Daily records of active and inactive Department stations, as well as some stations of other agencies, are available in the Department's files. Monthly and seasonal evaporation has been published in the Department's Annual or Biennial Reports on Hydrologic Data since the 1931-32 season.

COOPERATION

The Department receives evaporation data from The Metropolitan Water District, Palmdale Water District, California Department of Water Resources, and Descanso Gardens.

LENGTH OF RECORD

The first land pan installed by this Department was at Santa Anita Dam in March 1929. There are 30 evaporation stations which have records of 15 seasons or more in the Department's files.

EVAPORATION STATION LIST 1992-93

STA. NO.	STATION NAME	EQUIPMENT	ELEVATION OF PAN	THOMAS GUIDE	NORTH LATITUDE	WEST LONGITUDE
33 A	Pacoima Dam	24X36 S	1500 ft.	145 F9	34-19-48	118-23-59
46 D	Big Tujunga Dam	24X36 S	2315 ft.	F C2	34-17-40	118-11-14
63 C	Santa Anita Dam	24X36 S	1400 ft.	99 F2	34-11-03	118-01-12
89 B	San Dimas Dam	24X36 S	1350 ft.	95A C3	34-09-10	117-46-17
96 C	Puddingstone Dam	24X36 S	1030 ft.	89 F4	34-05-31	117-48-24
223 B	Big Dalton Dam	24X36 S	1587 ft.	87 F1	34-10-06	117-48-36
252 C	Castaic Reservoir	48X10 S	1150 ft.	(178)	34-29-53	118-36-53
334 B	Cogswell Dam	24X36 S	2300 ft.	G D4	34-14-37	117-57-35
390 B	Morris Dam	72X36 US	1210 ft.	86 F1	34-10-53	117-52-43
409 B	Pyramid Reservoir	48X10 S	2505 ft.	(154)	34-40-34	118-46-47
425 B	San Gabriel Dam	24X36 S	1481 ft.	H A5	34-12-19	117-51-38
1014 F	Rio Hondo S.G.	24X36 S	170 ft.	54 D3	33-59-57	118-06-04
1058 B	Palmdale	24X36 S	2595 ft.	172 F7	34-35-17	118-05-31
1071 B	Descanso Gardens	24X36 S	1325 ft.	19 B3	34-12-07	118-12-46

LEGEND

- 24X36 S** = Screened land pan, 24 inches in diameter by 36 inches deep.
48X10 S = Screened land pan, 48 inches in diameter by 10 inches deep.
72X36 US = Unscreened land pan, 72 inches in diameter by 36 inches deep.
() = Thomas Guide future page assignment.

MONTHLY EVAPORATION SUMMARY FOR WATER YEAR 1992-93 (inches)

STA. NO	STATION NAME	OCT.	NOV.	DEC.	JAN.	FEB.	MAR.	APR.	MAY	JUN.	JUL.	AUG.	SEP.	TOTAL
33 A	Pacoima Dam	6.98	9.11	4.88	4.53	3.16	5.80	8.22	7.29	7.55	7.06	8.82	9.66	83.03
46 D	Big Tujunga Dam	7.45	4.98	4.74	2.34	2.54	5.19	8.31	8.30	9.33	8.80	10.78	9.88	82.62
63 C	Santa Anita Dam	5.14	4.07	2.21	1.11	1.10	2.40	3.78	4.32	4.81	4.52	5.51	5.95	44.89
89 B	San Dimas Dam	3.67	2.61	1.60	1.60	2.76	2.55	4.00	5.65	5.98	6.44	7.18	5.73	49.75
96 C	Puddingstone Dam	5.38	4.05	2.34	1.62	1.75	3.64	6.02	7.86	8.35	8.49	9.17	8.03	66.66
223 C	Big Dalton Dam	3.61	2.91	1.33	1.16	2.27	2.24	3.95	4.97	6.58	5.85	7.04	5.92	47.79
252 C	Castaic Reservoir	6.10	5.04	7.61	2.69	4.03	3.70	5.69	6.23	5.46	6.77	8.40	8.30	70.02
334 B	Cogswell Dam	4.23	2.35	1.22	0.94	1.36	2.09	4.13	5.84	6.86	7.78	7.90	6.40	51.07
390 B	Morris Dam	6.68	5.34	3.56	2.57	2.95	5.41	7.04	8.29	9.18	9.11	10.51	9.95	80.60
409 B	Pyramid Reservoir	5.28	4.38	3.39	3.98	3.79	4.09	5.47	7.18	9.86	8.33	11.39	8.07	75.21
425 B	San Gabriel Dam	6.02	4.97	2.64	2.10	2.33	4.26	6.05	7.17	7.61	7.94	9.25	8.72	69.03
1014 F	Rio Hondo S.G.	3.51	3.03	2.69	1.95	2.31	2.80	4.74	6.19	6.39	6.68	6.78	5.12	52.17
1058 B	Palmdale	6.88	3.38	1.82	1.22	1.94	5.22	7.93	13.28	13.37	16.58	16.28	10.45	98.33
1071 B	Descanso Gardens	3.49	2.42	1.59	1.44	1.06	2.45	3.69	4.43	5.47	5.62	5.83	5.26	42.73

RUNOFF

RUNOFF

The Department operated or received data from 67 water-stage recording stations and 3 witness gages during the 1992-93 water year. Data from 40 of those stations are summarized and published in this volume.

The above normal rainfall during this report period and especially the heavy storm activity during February have resulted in heavy runoff in the rivers, channels, and streams. The Los Angeles River in particular during February 8th, experienced flow rates at near-channel capacity at some locations.

RECORDS OF STREAMFLOW

Records published give the following information:

1. Station description which presents location, drainage area, type of channel, control, regulations, diversions, and available records.
2. Discharge tabulation which summarizes the maximum, minimum, and mean of the daily flow rates in second-feet for each month and the total monthly volumes in acre-feet.

ALERT SYSTEM (AUTOMATIC LOCAL EVALUATION IN REAL TIME)

The Department of Public Works has installed a state-of-the-art ALERT computer system to monitor meteorological conditions at 59 locations in the County. The system includes a network of field sensors that monitor precipitation amounts, river stages, and reservoir levels.

During the report period, the Department has continued to install and expand its ALERT System. The Department's ALERT system is also now automatically receiving rainfall, streamflow, and reservoir data from the Corps of Engineers' Los Angeles Telemetry System.

COOPERATION

The Department receives streamflow data from other agencies, or has access to the records for local stations. Data from 5 of the Department's stations are published in the United States Geological Survey's annual water supply papers.

Agencies with which the Department exchanges data are:

United States Geological Survey, Water Resource Division
United States Corps of Engineers
State Department of Water Resources
The Metropolitan Water District
San Gabriel River Water Committee

LEGEND

Stations are designated by letters and numbers which indicate ownership, operation agency, and type of station. The letters used have the following connotations:

Prefix F - Indicates a station owned and operated by the Los Angeles County Department of Public Works.

Prefix E - Indicates a station owned by the Corps of Engineers, Department of the Army, but operated and maintained by the United States Geological Survey.

Prefix U - Indicates a station originally constructed and operated by the United States Geological Survey, Water Resources Division, now operated by the Department.

Prefix P - Indicates a station owned and operated by the Department, formerly operated by the Pasadena Water Department.

Prefix L - Indicates a station owned and operated by the Department, formerly owned by Little Rock Water District.

Suffix R - Indicates a recorder station.

Suffix B - Indicates that the station has been moved. B represents second location, C a third location, etc.

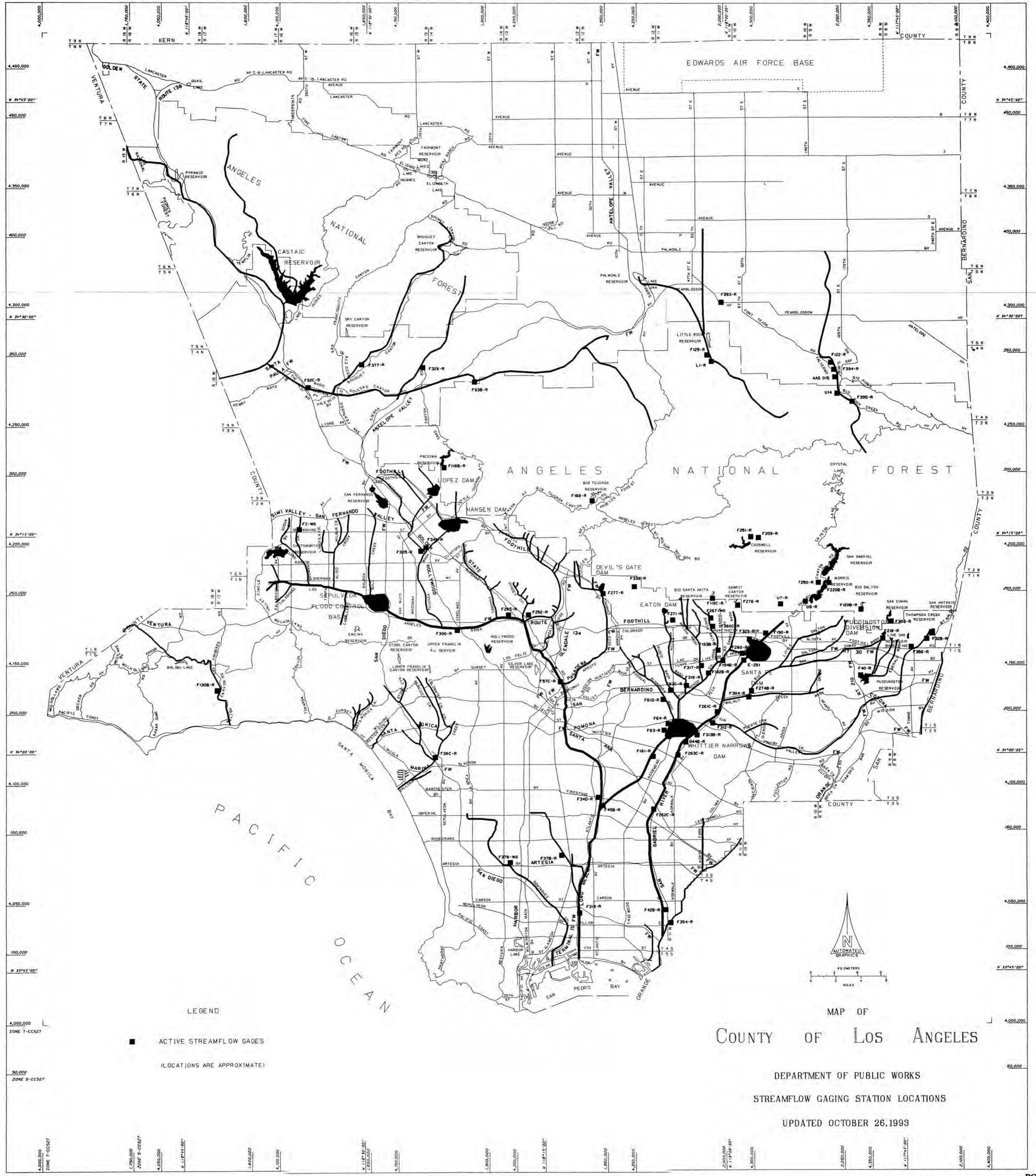

LEGEND

- ACTIVE STREAMFLOW GAGES
- (LOCATIONS ARE APPROXIMATE)

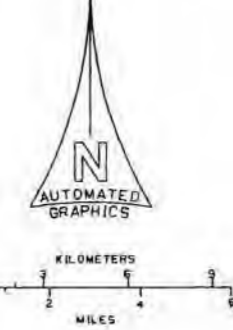

MAP OF
COUNTY OF LOS ANGELES

DEPARTMENT OF PUBLIC WORKS

STREAMFLOW GAGING STATION LOCATIONS

UPDATED OCTOBER 26, 1993

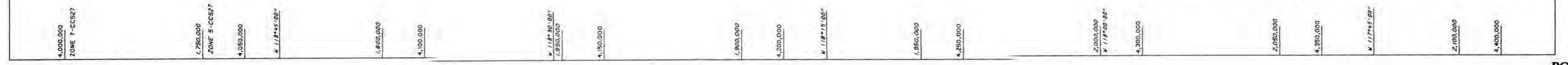

INDEX OF STREAM GAGING STATIONS

STATION	NAME	THOMAS GUIDE PG.	ALERT NO.	REGU- LATED	DRAINAGE AREA *
L1-R	LITTLE ROCK CREEK ABOVE LITTLE ROCK DAM	J		NO	49.20
F2WG	BROWNS CREEK AT VARIEL AVENUE	6 / D-2		NO	13.50
U7-R	FISH CREEK ABOVE MOUTH OF CANYON	86 / B-2		NO	6.36
U8-R	SAN GABRIEL RIVER BELOW MORRIS DAM	86 / F-1	415	YES	212.40
U14-R	BIG ROCK CREEK ABOVE MOUTH OF CANYON	J		NO	23.00
AAS(015)	VALYERMO S.G., BIG ROCK CK. D/S VALYERMO RD.	192/H-5			
F32B-R	THOMPSON CREEK BELOW THOMPSON CREEK DAM	96 / C-5	433	YES	3.70
F34D-R	LOS ANGELES RIVER BELOW FIRESTONE BLVD.	59 / E-3	315	YES	596.00
F37B-R	COMPTON CREEK NEAR GREENLEAF DRIVE	64 / F-4		NO	22.60
F38C-R	BALLONA CREEK ABOVE SAWTELLE BLVD.	50 / B-3	369	YES	88.60
F40-R	PUDDINGSTONE CREEK BELOW PUDDINSTONE DAM	89 / F-4	427	YES	33.20
F42B-R	SAN GABRIEL RIVER ABOVE SPRING STREET	76 / F-1	435	YES	231.00
F45B-R	RIO HONDO ABOVE STUART AND GRAY ROAD	59 / E-3	307	YES	140.00
F57C-R	LOS ANGELES RIVER ABOVE ARROYO SECO	35 / F-5		YES	511.00
F64-R	RIO HONDO ABOVE MISSION BRIDGE	47 / B-5		YES	115.00
F81D-R	ALHAMBRA WASH NEAR KLINGERMAN STREET	46 / F-2	347	NO	15.20
F82C-R	RUBIO WASH AT GLENDON WAY	38 / A-6	353	YES	10.90
F83	MISSION CREEK AT SAN GABRIEL BLVD.			YES	4.2
F92C-R	SANTA CLARA RIVER AT OLD ROAD BRIDGE	123 / G-7		YES	410.40
F93	SANTA CLARA RIVER AT LANG RAILROAD BRIDGE	125 / J-7		NO	157.30
F118B-R	PACOIMA CREEK FLUME BELOW PACOIMA DAM	3 / C-1	330	YES	28.20
F119C-R	SANTA ANITA CREEK BELOW SANTA ANITA DAM	20A / F-2	345	YES	10.80
F120B-R	BIG DALTON CREEK BELOW BIG DALTON DAM	87 / F-2	418	YES	4.80
F122-R	PALLETT CREEK AT VALYERMO HIGHWAY	199 / G-4		NO	15.80
F125-R	SANTIAGO CREEK ABOVE LITTLE ROCK CREEK	J		NO	11.20
F130-R	MALIBU CREEK BELOW COLD CREEK	107 / F-6		YES	104.96
F168-R	BIG TUJUNGA CREEK BELOW BIG TUJUNGA DAM	M / C-2	333	YES	82.30
F181-R	MONTEBELLO STORM DRAIN OUTLET TO RIO HONDO	54 / E-3		NO	9.60
F190-R	SAN GABRIEL RIVER AT FOOTHILL BLVD.	86 / A-5		YES	230.00
F192B-R	RIO HONDO BELOW LOWER AZUSA ROAD	38 / E-4		YES	40.90
F193B-R	SANTA ANITA WASH AT LONGDEN AVENUE	38 / F-1		YES	18.80
F194B-R	SAWPIT WASH BELOW LIVE OAK AVENUE	39 / A-2		YES	16.10
F209-R	SAN GABRIEL RIVER - W. FORK BELOW COGSWELL DAM	N / D-4	410	YES	41.00
F218-R	SAN DIMAS WASH BELOW PUDD. DIVERSION DAM	95A / C-5	424	YES	19.90
F220B-R	SAN GABRIEL - AZUSA CONDUIT 10FT WEIR BELOW DAM	P / A-5		YES	0.00
F250-R	SAN GABRIEL - AZUSA CONDUIT 25FT WEIR BELOW DAM	P / A-5		YES	202.70
F251-R	SAN GABRIEL W. FORK AT TOE OF COGSWELL DAM	N / D-4		YES	39.20
F252-R	VERDUGO WASH AT ESTELLE AVENUE	25 / B-3		YES	26.80
F260C-R	SANTA ANITA WASH BELOW FOOTHILL BLVD.	28 / E-3		YES	17.20
F261C-R	SAN GABRIEL RIVER BELOW VALLEY BLVD.	48 / A-2	351	YES	118.00
F262B-R	SAN GABRIEL RIVER ABOVE FLORENCE AVE.	60 / E-4		YES	215.80
F263C-R	SAN GABRIEL RIVER BELOW S.G. RIVER PKWY	55 / C-1		YES	206.30
F267WG	SIERRA MADRE WASH AT HIGHLAND OAKS AVENUE	28 / E-3		YES	3.80
F271-R	EATON WASH BELOW EATON WASH DAM	27 / F-1	342	YES	12.40
F274B-R	DALTON WASH AT MERCED AVENUE	48 / F-1		YES	35.95
F277-R	ARROYO SECO BELOW DEVIL'S GATE DAM	19 / D-5	336	YES	32.50
F278-R	SAWPIT CREEK BELOW SAWPIT DAM	29 / C-1	339	YES	3.30
F280-R	SANTA FE DIVERSION CHANNEL BELOW SANTA FE DAM	39 / D-2		YES	CONTROLLED
E285-R	BURBANK WESTERN STORM DRAIN AT RIVERSIDE DR.	24 / E-2		YES	25.00
F300-R	LOS ANGELES RIVER AT TUJUNGA AVE.	23 / D-4		YES	401.00

INDEX OF STREAM GAGING STATIONS

STATION	NAME	THOMAS GUIDE PG.	ALBRT NO.	REGU- LATED	DRAINAGE AREA *
F303-R	SAN DIMAS CREEK BELOW SAN DIMAS DAM	95A / C-3	421	YES	16.20
F304-R	WALNUT CREEK ABOVE PUENTE AVENUE	48 / D-1		YES	57.60
F305-R	PACOIMA DIVERSION AT BRANFORD STREET	9 / A-5		YES	48.80
F312-R	SAN JOSE CHANNEL ABOVE WORKMAN MILL ROAD	47 / F-5	324	YES	83.40
F313B-R	RIO HONDO BYPASS CHANNEL ABOVE WHITTIER NAR.	47 / B-5		YES	CONTROLLED
F317-R	ARCADIA WASH BELOW GRAND AVENUE	38 / E-3	355	YES	8.50
F318-R	EATON WASH AT LOFTUS DRIVE	34 / C-6		YES	22.80
F319-R	LOS ANGELES RIVER BELOW WARDLOW RIVER RD.	70 / B-5	313	YES	815.00
F328-R	MINT CANYON CREEK AT FITCH AVENUE	125 / C-5		NO	26.90
F329-R	BRADBURY CHANNEL BELOW CENTRAL AVENUE	29 / F-5		YES	3.30
F338-R	RUBIO DIV. CHANNEL BEL. GOOSEBERRY CYN INLET	20 / C-4		YES	2.10
F342-R	BRANFORD STREET CHANNEL BELOW SHARP AVE.	9 / B-5		YES	5.01
F354-R	COYOTE CREEK BELOW SPRING STREET	76 / F-1	437	YES	185.00
F356-R	LIVE OAK CREEK BELOW LIVE OAK DAM	95A / F-6	430	YES	2.28
F377-R	BOUQUET CANYON CREEK AT URBAN DALE AVENUE	124 / F-5		YES	51.90
F378WG	DOMINGUEZ CHANNEL BELOW WESTERN AVENUE	63 / F-5		NO	37.10
F393-R	LITTLE ROCK AT HIGHWAY 138	184 / D-6		YES	70.00
F394-R	BIG ROCK CREEK UPSTREAM FROM PALLETT CREEK	192 / J-4		NO	34.30
F395-R	MESCAL CREEK AT MOUTH	J		NO	5.71
G44B-R	SAN GABRIEL RIVER ABOVE WHITTIER NAR. DAM	47 / C-6		NO	

* NOTE: All drainage areas in square miles.

LITTLE ROCK CREEK

above Little Rock Dam

STATION NO. L1-R

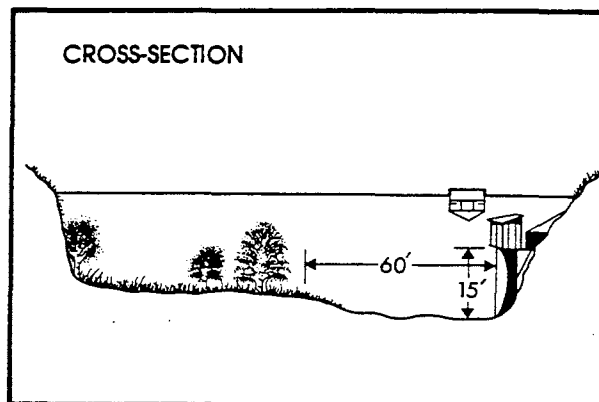
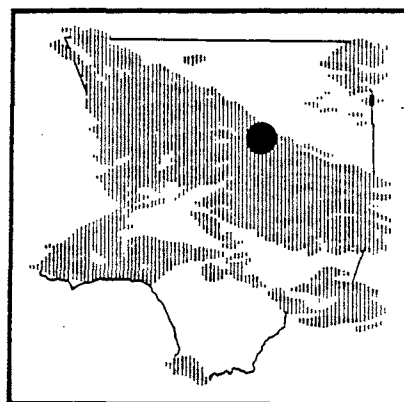
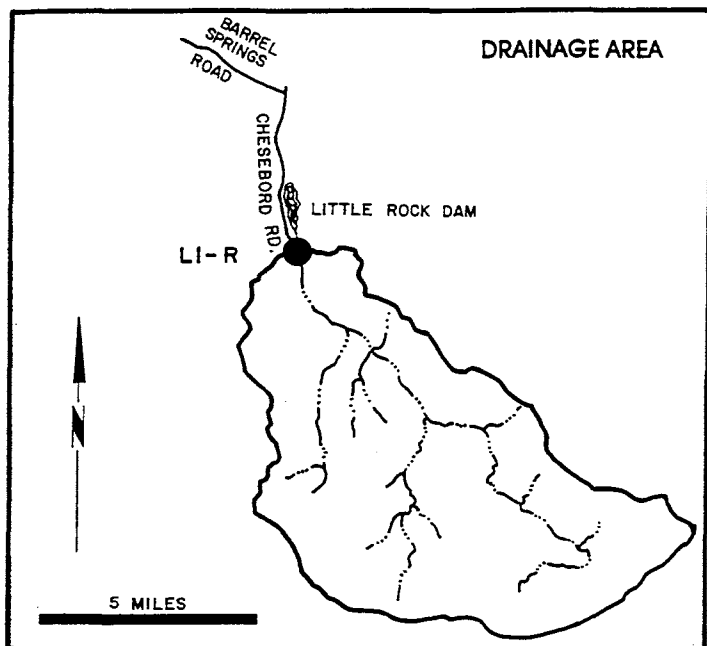

RECORDER- continuous water stage.
 METHOD OF MEASUREMENTS- wading or from cable car.
 DRAINAGE AREA- 49.2 square miles.
 LOCATION- 2.0 miles above Little Rock Dam, 5.0 miles south of Little Rock.
 REGULATION- none.
 CHANNEL- sand, gravel, and boulders, natural in section.
 CONTROL- channel forms control.
 LENGTH OF RECORD- October 1, 1930 to date.

WATER YEAR 1992 – 1993 (DISCHARGE IN CFS)

STATION NO.: L1-R

DRAINAGE AREA: 49.20 SQ. MI.

MONTH	OCT	NOV	DEC	JAN	FEB	MAR	APR	MAY	JUN	JUL	AUG	SEP
MEAN	0.6	2.7	9.7	210.0			102.0	42.5				
MAX	1.5	3.8	44.8	854.0	NO RECORDS			151.0	66.0	RECORDER INOPERATIVE		
MIN	0.0	1.7	2.9	9.8			65.7	19.5				
TOTAL AF	35.0	163.0	598.0	12,910.0			6,059.0	2,616.0				

FISH CREEK

above Mouth of Canyon
STATION NO. U7-R

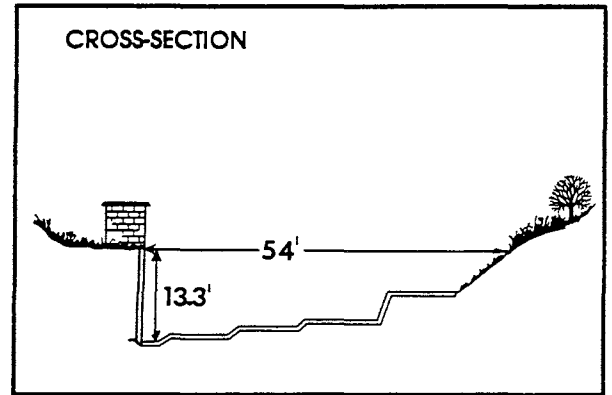
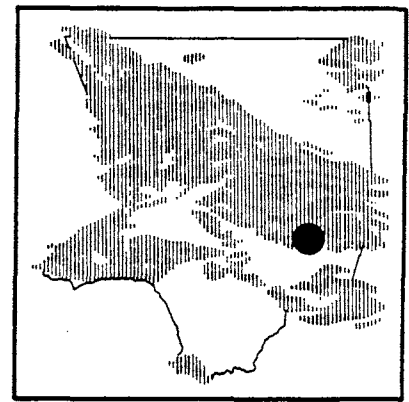
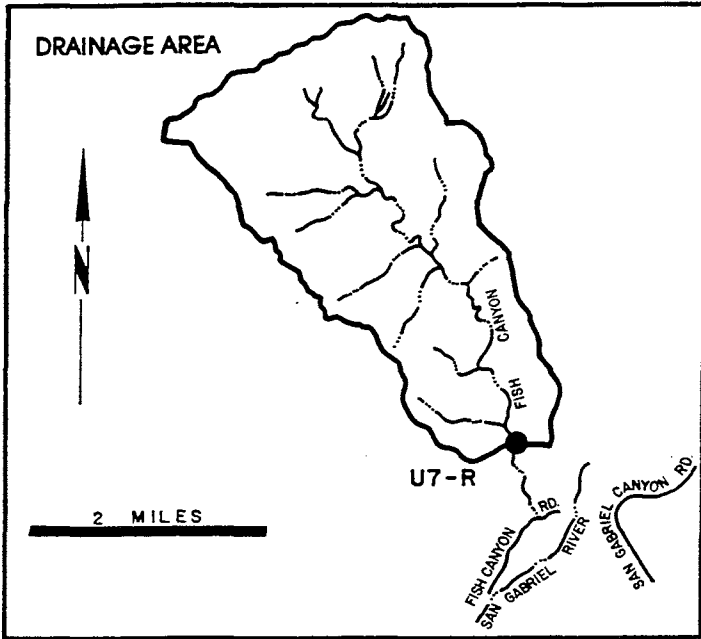

RECORDER- continuous water stage.
 METHOD OF MEASUREMENTS- wading.
 DRAINAGE AREA- 6.36 square miles.
 LOCATION - 0.8 miles upstream of mouth of canyon and 3.0 miles northeast of Duarte.
 REGULATION- none.
 CHANNEL- natural, rock and gravel.
 CONTROL- concrete control.
 LENGTH OF RECORD- July to September 1916. July 1917 to date.
 REMARKS- operated and maintained by USGS until October 1, 1971.

WATER YEAR 1992–1993 (DISCHARGE IN CFS)

STATION NO. : U7-R

DRAINAGE AREA : 6.36 SQ. MI.

MONTH	OCT	NOV	DEC	JAN	FEB	MAR	APR	MAY	JUN	JUL	AUG	SEP
MEAN	1.4	2.9	7.0	96.3	77.4	27.8	14.1	6.4	5.1	4.1	2.2	1.6
MAX	26.9	28.4	66.7	397.0	422.0	67.1	18.4	7.4	14.0	9.8	2.8	1.8
MIN.	0.3	1.2	1.0	3.8	27.2	12.6	10.2	5.6	4.0	2.8	1.9	1.4
TOTAL AF	88.0	174.0	432.0	5,919.0	4,301.0	1,709.0	840.0	393.0	301.0	250.0	135.0	95.0

SAN GABRIEL RIVER

below Morris Dam

STATION NO.U8-R

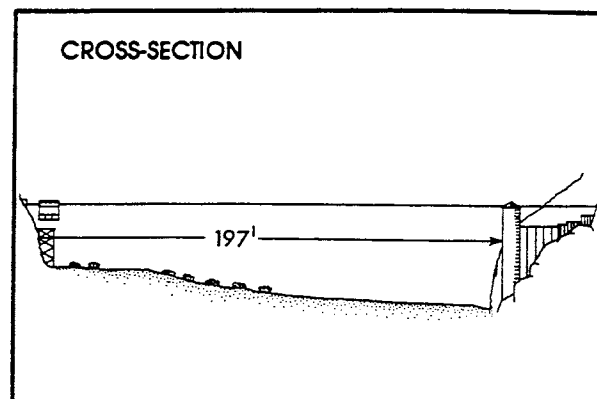
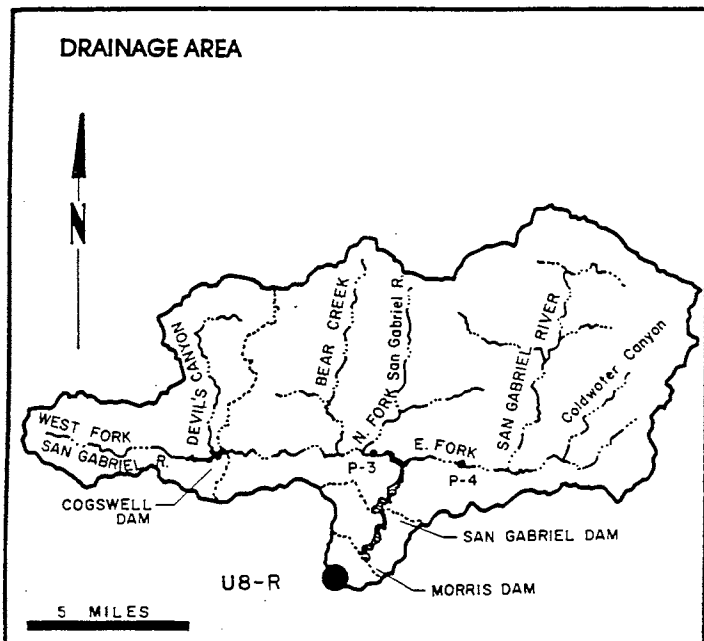
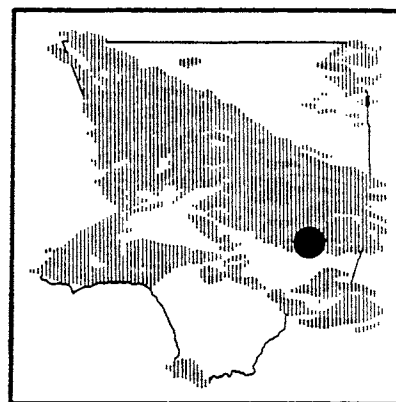

RECORDER- continuous water stage.

METHOD OF MEASUREMENTS- wading or from cable car.

DRAINAGE AREA- 212.4 square miles.

LOCATION- 1.1 miles downstream of Morris Dam, 2.7 miles northeast of Azusa.

REGULATION- all flows regulated by Cogswell, San Gabriel, and Morris Dams.

CHANNEL- gravel and boulders, natural section.

CONTROL- concrete control.

LENGTH OF RECORD- May 1894 to date.

REMARKS- flows up to 90 cfs are at times diverted past the station through the Azusa Conduit; flows at station may include imported water from the MWD outlet below Morris Dam.

WATER YEAR 1992-1993

(DISCHARGE IN CFS)

STATION NO. : U8-R

DRAINAGE AREA : 212.40 SQ. MI.

MONTH	OCT	NOV	DEC	JAN	FEB	MAR	APR	MAY	JUN	JUL	AUG	SEP
MEAN	223.0	308.0	261.0	2,062.0	2,487.0	729.0	698.0	508.0	167.0	191.0	187.0	177.0
MAX.	478.0	471.0	365.0	9,500.0	7,810.0	1,340.0	767.0	705.0	327.0	221.0	362.0	362.0
MIN.	75.5	266.0	169.0	0.0	294.0	599.0	641.0	0.5	0.5	4.1	8.0	3.7
TOTAL AF	13,720.0	18,340.0	16,030.0	126,800.0	138,100.0	44,850.0	41,510.0	31,230.0	9,965.0	11,750.0	11,470.0	10,560.0

LOS ANGELES RIVER below Firestone Boulevard STATION NO. F34D-R

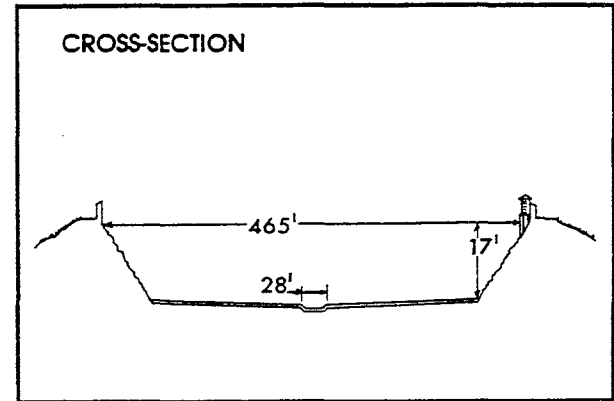
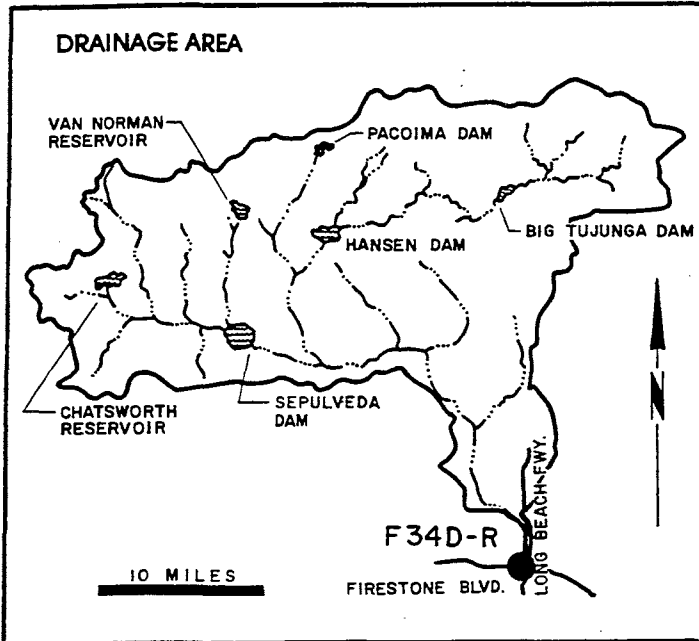
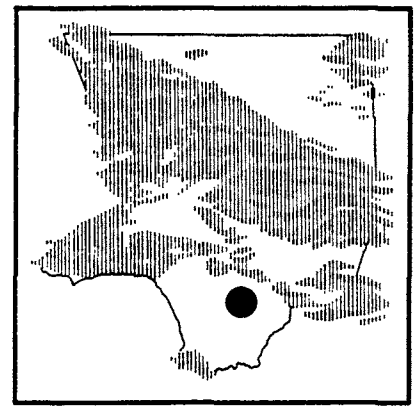

RECORDER- continuous water stage.

METHOD OF MEASUREMENTS- wading or from bridge.

DRAINAGE AREA- 596.0 square miles.

LOCATION- 472.0 feet downstream of Firestone Boulevard 3.0 miles west of Downey.

REGULATION- partially regulated by Sepulveda, Pacoima, Big Tujunga, Hansen, and Devil's Gate Dam; and by several spreading grounds, reservoirs, and debris basins.

CHANNEL- concrete, with rip-rap side slopes, trapezoidal in section, with trapezoidal low-flow channel.

CONTROL- channel forms control.

LENGTH OF RECORD- at Station F34-R. March 1, 1928 to April 11, 1938. at Station F34B-R, April 11, 1938 to November 3, 1949. at Station F34C-R November 4, 1949, to December 11, 1956. at Station F34D-R December 11, 1956 to date.

REMARKS- subject to diversions from Big Tujunga Creek, Arroyo Seco, and other domestic and irrigation diversions.

WATER YEAR 1992-1993 (DISCHARGE IN CFS)

STATION NO. : F34D-R

DRAINAGE AREA : 596.00 SQ. MI.

MONTH	OCT	NOV	DEC	JAN	FEB	MAR	APR	MAY	JUN	JUL	AUG	SEP
MEAN	189.0	155.0	811.0	3,081.0	3,053.0	786.0	187.0	155.0	237.0	140.0	125.0	118.0
MAX	1,490.0	216.0	14,500.0	17,000.0	14,500.0	6,410.0	199.0	170.0	2,430.0	150.0	130.0	121.0
MIN.	111.0	131.0	129.0	170.0	194.0	202.0	170.0	148.0	145.0	132.0	121.0	115.0
TOTAL AF	11,640.0	9,247.0	49,870.0	189,400.0	169,600.0	48,320.0	11,100.0	9,535.0	14,090.0	8,614.0	7,668.0	7,010.0

COMPTON CREEK

near Greenleaf Drive

STATION NO. F37B-R

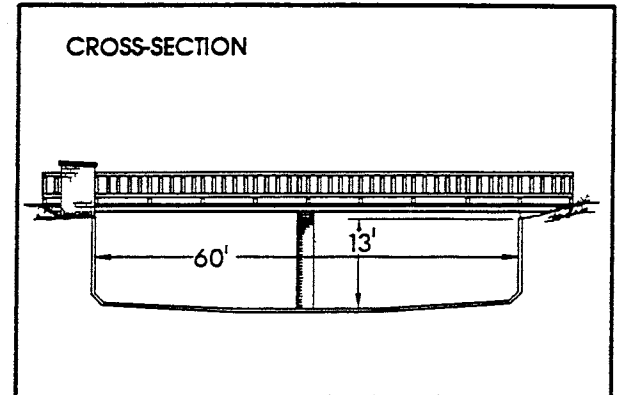
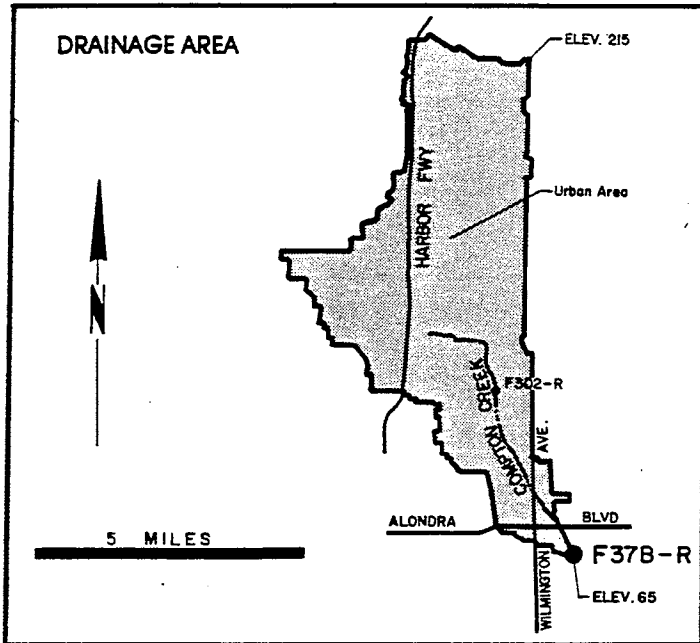
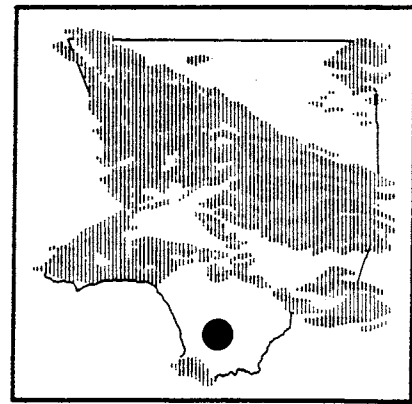

RECORDER- continuous water stage.

METHOD OF MEASUREMENTS- wading or from bridge.

DRAINAGE AREA- 22.6 square miles.

LOCATION- 120.0 feet above Greenleaf Boulevard, 1.5 miles south west of Compton.

REGULATION- none.

CHANNEL- concrete, rectangular in section, 60 feet wide by 13 feet deep.

CONTROL- channel forms control.

LENGTH OF RECORD- at Station F37-R January 22, 1928 to June 9, 1938. at Station F37B-R October 3, 1938 to date

WATER YEAR 1992-1993

(DISCHARGE IN CFS)

STATION NO. : F37B-R

DRAINAGE AREA : 22.60 SQ. MI.

MONTH	OCT	NOV	DEC	JAN	FEB	MAR	APR	MAY	JUN	JUL	AUG	SEP
MEAN	6.7	1.6	40.0	116.0	66.3	21.9	1.2	0.9	5.5	0.9	0.9	1.1
MAX.	73.9	2.9	700.0	717.0	499.0	365.0	2.9	1.3	122.0	1.2	1.2	1.5
MIN.	0.9	0.9	3.6	0.9	5.2	1.3	0.6	0.6	0.1	0.6	0.2	0.9
TOTAL AF	415.0	93.0	2,458.0	7,136.0	3,681.0	1,349.0	68.0	55.0	328.0	52.0	58.0	68.0

BALLONA CREEK above Sawtelle Boulevard STATION NO. F38C-R

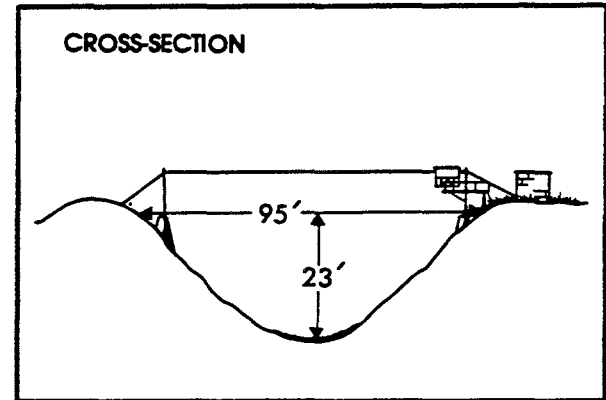
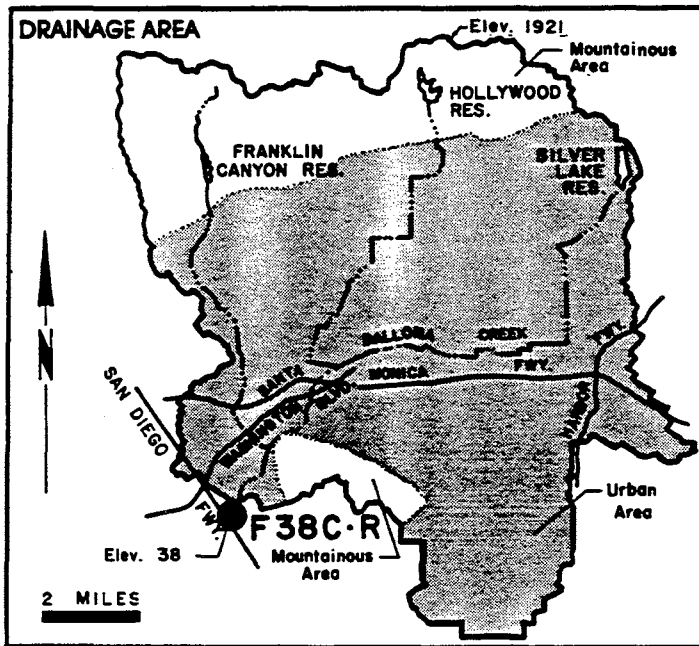
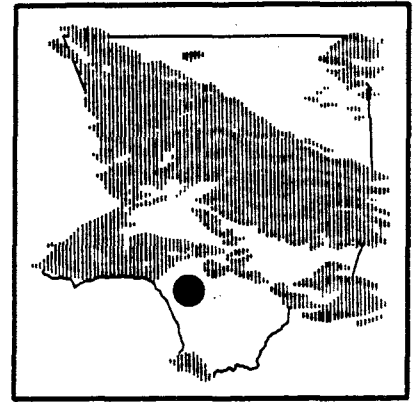

RECORDER- continuous water stage.

METHOD OF MEASUREMENTS- wading or from cable car.

DRAINAGE AREA- 88.6 square miles.

LOCATION- 530.0 feet above Sawtelle Boulevard, 1.5 miles southwest of Culver City.

REGULATION- Stone Canyon Reservoir prior to January, 1951. Upper and Lower Franklin Canyon Reservoir, Hollywood Reservoir, and Silverlake Reservoir.

CHANNEL- concrete rubble, trapezoidal in section.

CONTROL- channel forms control.

LENGTH OF RECORD- at Station F38-R February 27, 1928 to April 27, 1936. at Station F38B-R, May 14, 1936 to August 10, 1967. at Station F38C-R August 10, 1967, to date.

WATER YEAR 1992-1993 (DISCHARGE IN CFS)

STATION NO. : F38C-R

DRAINAGE AREA : 88.60 SQ. MI.

MONTH	OCT	NOV	DEC	JAN	FEB	MAR	APR	MAY	JUN	JUL	AUG	SEP
MEAN	35.6	7.6	150.0			106.0	31.4	16.5	40.7	11.3	10.1	13.9
MAX.	716.0	7.7	2,350.0	NO RECORDS		1,450.0	51.4	19.7	895.0	18.8	11.1	23.8
MIN.	7.0	7.2	7.0			21.7	19.7	13.1	9.9	9.9	8.7	9.5
TOTAL AF	2,190.0	452.0	9,196.0			6,531.0	1,871.0	1,014.0	2,421.0	697.0	619.0	830.0

SAN GABRIEL RIVER

above Spring Street

STATION NO. F42B-R

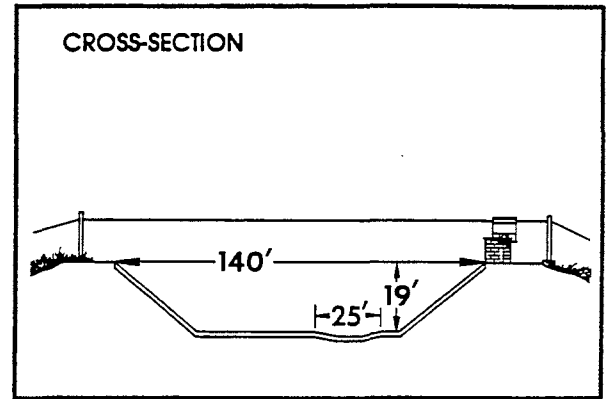
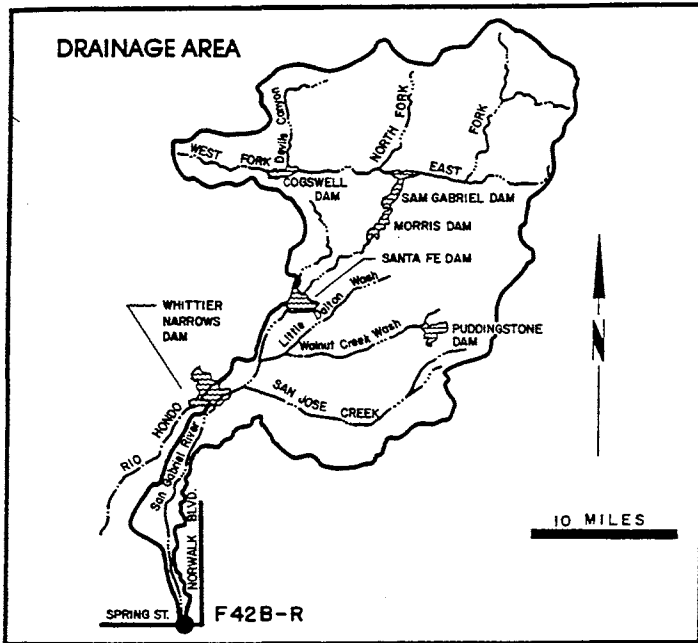
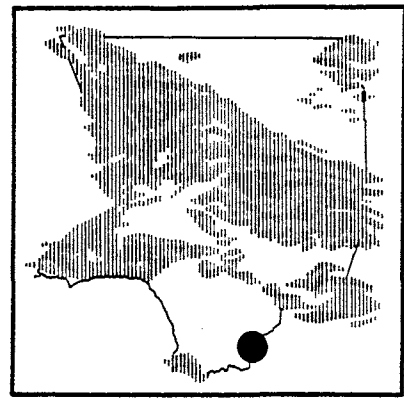

RECORDER- continuous water stage.

METHOD OF MEASUREMENTS- wading or from cable car.

DRAINAGE AREA- 231.0 square miles (excludes area above Santa Fe Dam).

LOCATION- 455.0 feet north of Spring Street, 4.0 miles east of Signal Hill, Long Beach.

REGULATION- partially regulated by Cogswell, San Gabriel, Morris, Santa Fe, Big Dalton, San Dimas, Puddingstone Diversion, Puddingstone, Live Oak, Thompson Creek, and Whittier Narrows Dams, several debris basins, MWD outlet, and several spreading grounds.

CHANNEL- concrete, trapezoidal section with a low-flow channel.

CONTROL- channel forms control.

LENGTH OF RECORD- at Station F42-R February 6, 1928 to May 26, 1964. at Station F42B-R, November 16, 1964 to date.

REMARKS- high flows into Whittier Narrows Reservoir are partially diverted to the Rio Hondo.

WATER YEAR 1992-1993

(DISCHARGE IN CFS)

STATION NO. : F42B-R

DRAINAGE AREA : 231.00 SQ. MI.

MONTH	OCT	NOV	DEC	JAN	FEB	MAR	APR	MAY	JUN	JUL	AUG	SEP
MEAN	40.7	80.7	183.0	1,945.0	1,331.0	452.0	156.0				36.1	58.2
MAX.	121.0	151.0	1,690.0	6,480.0	5,090.0	2,830.0	179.0		NO RECORDS		61.2	115.0
MIN.	30.0	37.6	37.0	115.0	156.0	111.0	112.0				22.9	22.6
TOTAL AF	2,506.0	4,801.0	11,240.0	119,600.0	73,900.0	27,760.0	9,299.0				2,218.0	3,462.0

RIO HONDO

above Stewart and Gray Road

STATION NO. F45B-R

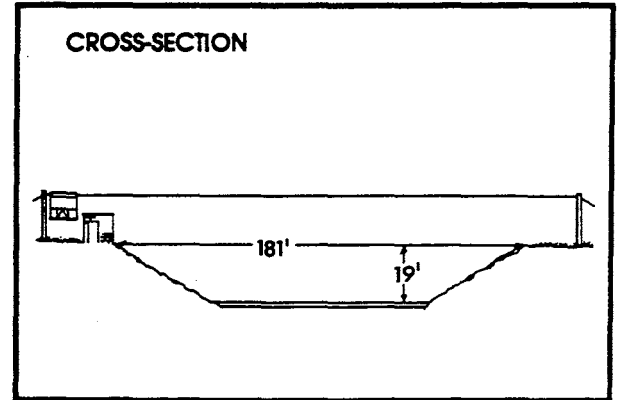
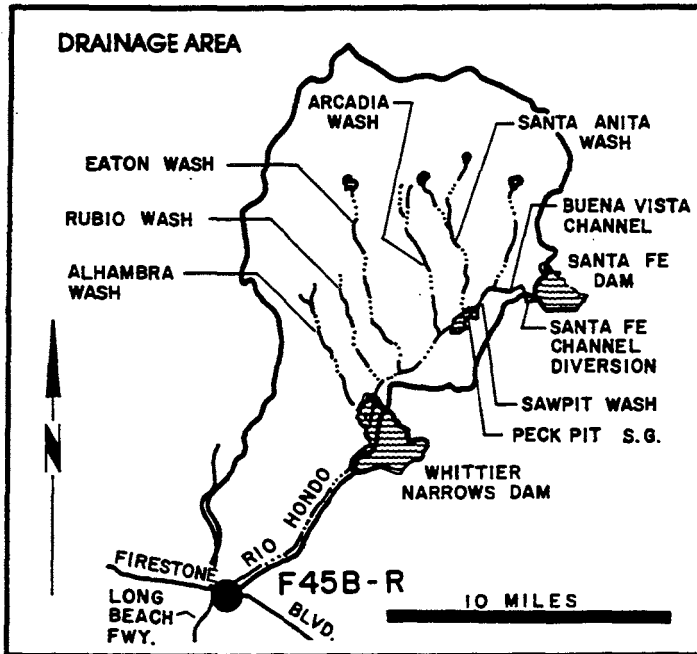
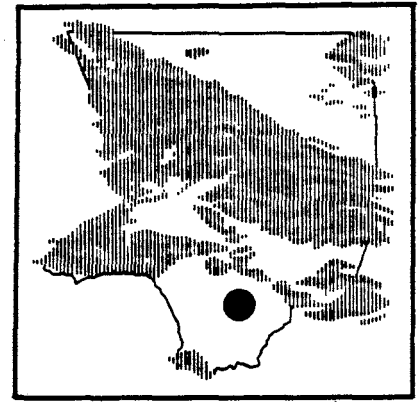

RECORDER- continuous water stage.

METHOD OF MEASUREMENTS- wading or from cable car.

DRAINAGE AREA- 140 square miles (excludes area above Santa Fe Dam).

LOCATION- 0.6 mile upstream of the confluence of Rio Hondo and Los Angeles River, 1.5 miles west of Downey.

REGULATION- partially regulated by Sierra Madre, Santa Anita, Sawpit, Eaton, Santa Fe, and Whittier Narrows Dams, several debris basins, and spreading grounds.

CHANNEL- concrete with rip-rap side slopes. trapezoidal in section.

CONTROL- channel forms control.

LENGTH OF RECORD- at Station F45-R March 1, 1928 to April 18, 1951. at Station F45B-R October 31, 1951 to date.

REMARKS- subject to diversions from Eaton Creek, Monrovia Creek, Sawpit Creek, Little Santa Anita Canyon and other locations for irrigation and spreading. High flows from San Gabriel River may flow into Rio Hondo above Whittier Narrows Dam.

WATER YEAR 1992-1993

(DISCHARGE IN CFS)

STATION NO. : F45B-R

DRAINAGE AREA : 140.00 SQ. MI.

MONTH	OCT	NOV	DEC	JAN	FEB	MAR	APR	MAY	JUN	JUL	AUG	SEP
MEAN	3.2	0.2	248.0	2,031.0	2,397.0	83.1	1.3	0.5	10.4	0.3	0.3	0.2
MAX.	60.1	0.6	7,040.0	11,200.0	9,770.0	1,370.0	7.7	0.8	243.0	0.5	0.5	0.6
MIN.	0.5	0.1	0.0	0.1	3.1	0.1	0.2	0.2	0.0	0.1	0.1	0.1
TOTAL AF	200.0	13.0	15,220.0	124,900.0	133,100.0	5,111.0	76.0	31.0	616.0	18.0	17.0	11.0

RIO HONDO above Mission Bridge STATION NO. F64-R

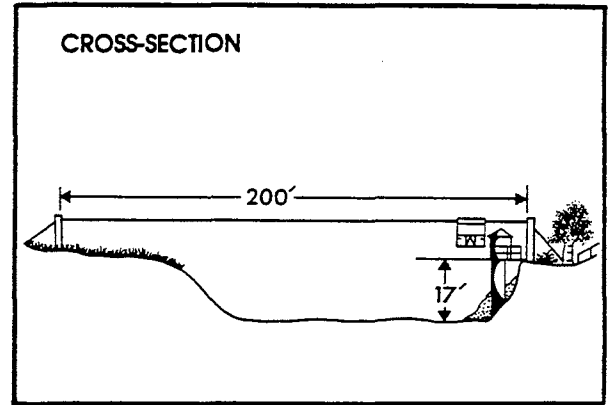
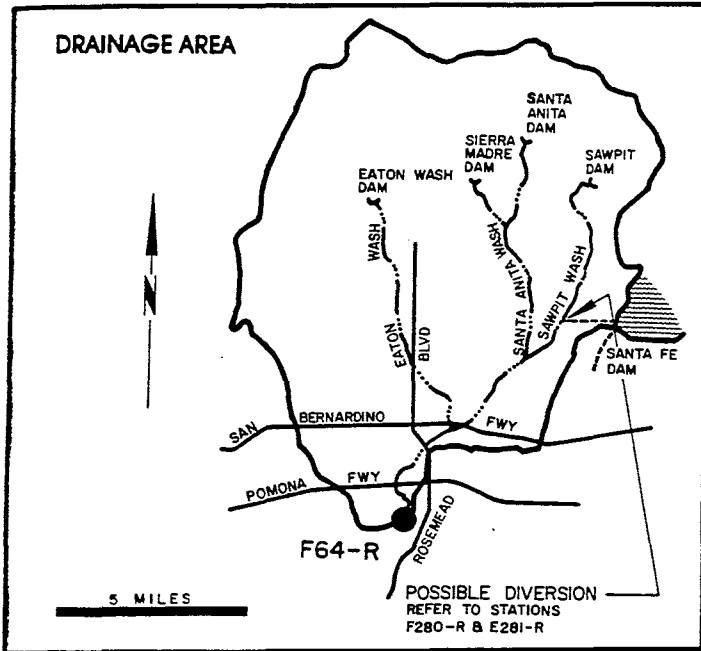
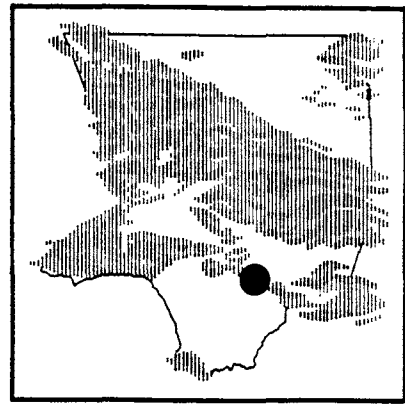

- RECORDER- continuous water stage.
- METHOD OF MEASUREMENTS- wading or from cable car.
- DRAINAGE AREA- 115 square miles (excludes area above Santa Fe Dam).
- LOCATION- 1,000 feet above San Gabriel Boulevard, west of Rosemead Boulevard, 2.0 miles northeast of Montebello.
- REGULATION- partially regulated by Sierra Madre, Santa Anita, Sawpit, Eaton, and Santa Fe Dams and several debris basins.
- CHANNEL- sand and silt, natural in section.
- CONTROL- none.
- LENGTH OF RECORD- July 1, 1928 to date.
- REMARKS- subject to diversions; water purchased from the MWD passes this station for spreading in the coastal basin.

WATER YEAR 1992-1993 (DISCHARGE IN CFS)

STATION NO. : F64-R

DRAINAGE AREA : 115.00 SQ. MI.

MONTH	OCT	NOV	DEC	JAN	FEB	MAR	APR	MAY	JUN	JUL	AUG	SEP
MEAN	142.0	46.1	*	*	*	*	46.2	12.4	*	79.7	66.8	45.4
MAX.	1,910.0	200.0	*	*	*	*	86.6	20.6	*	107.0	143.0	128.0
MIN.	35.4	20.9	*	*	*	*	6.3	4.9	*	19.2	5.1	27.6
TOTAL AF	8,748.0	2,740.0	*	*	*	*	2,746.0	760.0	*	4,899.0	4,110.0	2,704.0

LEGEND * - Data inaccurate due to back water condition.

ALHAMBRA WASH near Klingerman Street STATION NO. F81D-R

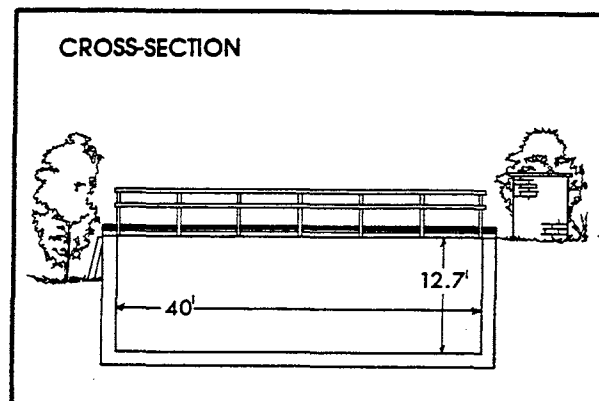
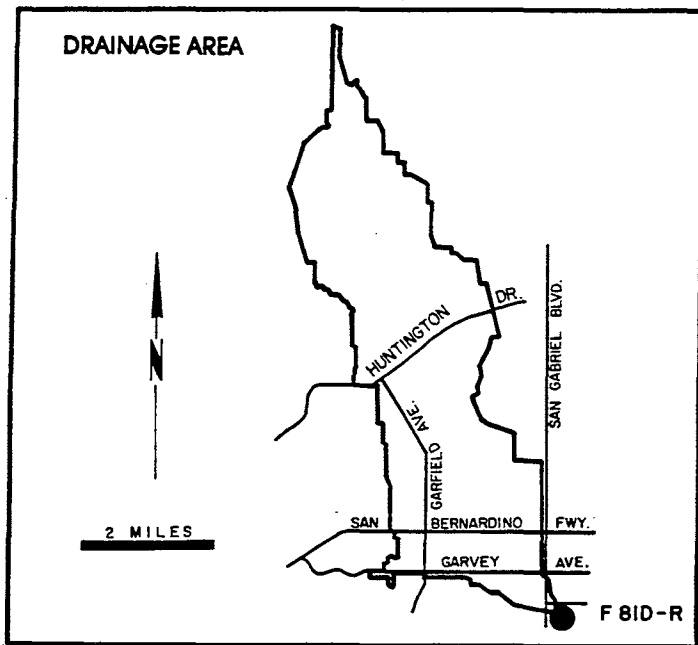
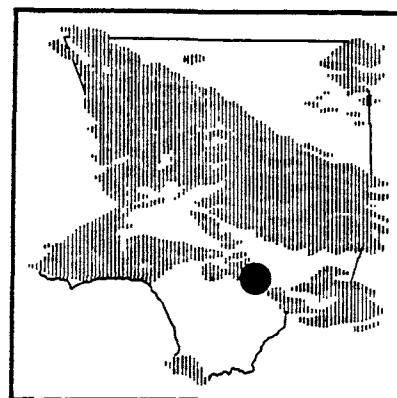

RECORDER- continuous water stage.

METHOD OF MEASUREMENTS- wading or from footbridge.

DRAINAGE AREA- 15.2 square miles.

LOCATION- 250± feet above Klingerman Street and 2,650.0 feet below Garvey Avenue, South San Gabriel.

REGULATION- none.

CHANNEL- concrete, rectangular in section, 40.0 feet wide by 12.7 feet deep.

CONTROL- channel forms control.

LENGTH OF RECORD- at Station F81- R January 14, 1930 to September 30, 1934. at Station F81B- R October 1, 1934 to February 25, 1935. at Station F81C- R February 25, 1935 to April 27, 1936. at Station F81B- R April 27, 1936 to May 22, 1936. at Station F81D- R September 2, 1936 to date.

WATER YEAR 1992-1993 (DISCHARGE IN CFS)

STATION NO. : F81D-R

DRAINAGE AREA : 15.20 SQ. MI.

MONTH	OCT	NOV	DEC	JAN	FEB	MAR	APR	MAY	JUN	JUL	AUG	SEP
MEAN	9.4	1.9	40.9	94.6	56.2	18.0	2.3	2.3	11.9	3.6	2.5	3.2
MAX	203.0	2.2	796.0	626.0	456.0	253.0	2.9	5.2	157.0	12.1	9.0	10.3
MIN	1.9	1.6	1.2	1.0	1.4	1.4	2.0	1.9	2.2	1.7	1.7	2.0
TOTAL AF	577.0	115.0	2,517.0	5,816.0	3,120.0	1,108.0	136.0	144.0	705.0	224.0	154.0	191.0

RUBIO WASH at Glendon Wash STATION NO. F82C-R

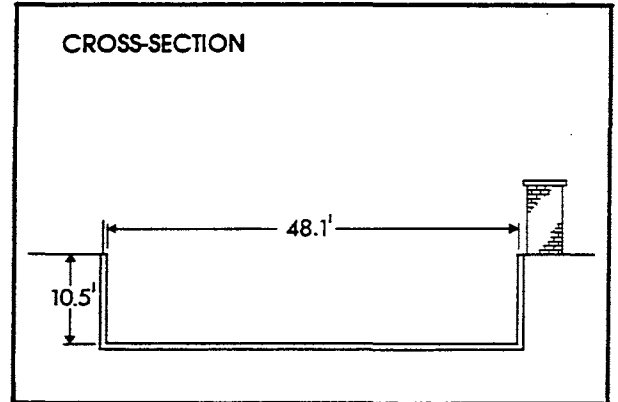
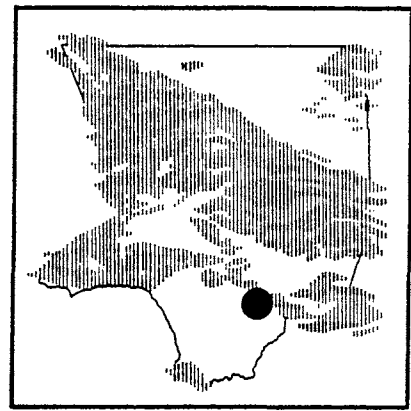
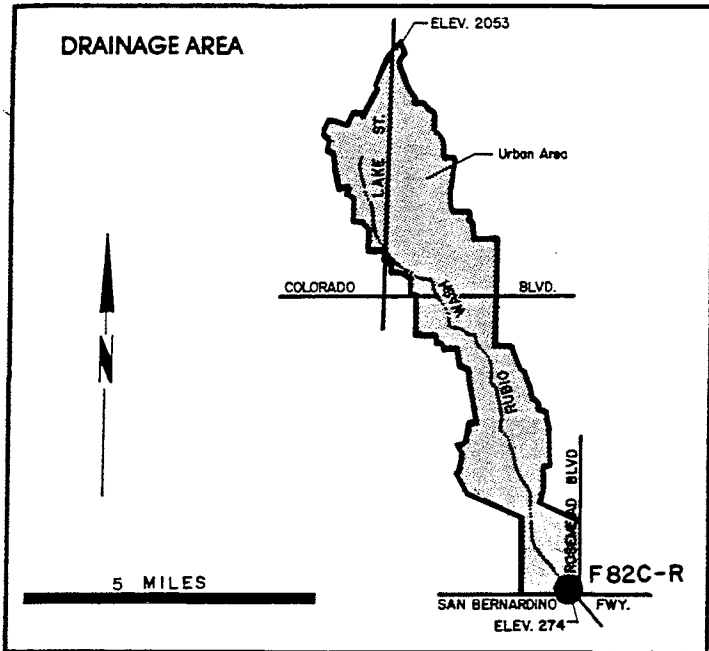

RECORDER- 15 minute punched tape.

METHOD OF MEASUREMENTS- low flows measured by wading. High flows measured from footbridge at station.

DRAINAGE AREA- 10.9 square miles.

LOCATION- on the east side of channel, 10 feet south of the westerly extension of Glendon Way, Rosemead.

REGULATION- flow partly regulated by Las Flores and Rubio debris basins.

CHANNEL- rectangular concrete.

CONTROL- channel forms control.

LENGTH OF RECORD- see station summary.

WATER YEAR 1992-1993 (DISCHARGE IN CFS)

STATION NO. : F82C-R

DRAINAGE AREA : 10.90 SQ. MI.

MONTH	OCT	NOV	DEC	JAN	FEB	MAR	APR	MAY	JUN	JUL	AUG	SEP
MEAN	3.4	0.0	16.9	40.9	22.5	8.0	0.1	0.2	2.8	0.2	0.2	0.1
MAX.	94.6	0.1	323.0	308.0	210.0	135.0	0.2	0.3	77.8	0.3	0.5	0.2
MIN.	0.1	0.0	0.0	0.1	0.1	0.1	0.1	0.1	0.1	0.1	0.1	0.1
TOTAL AF	211.0	2.0	1,039.0	2,515.0	1,252.0	489.0	8.0	12.0	165.0	13.0	11.0	9.0

SANTA CLARA RIVER

below Highway 5

STATION NO. F92C-R

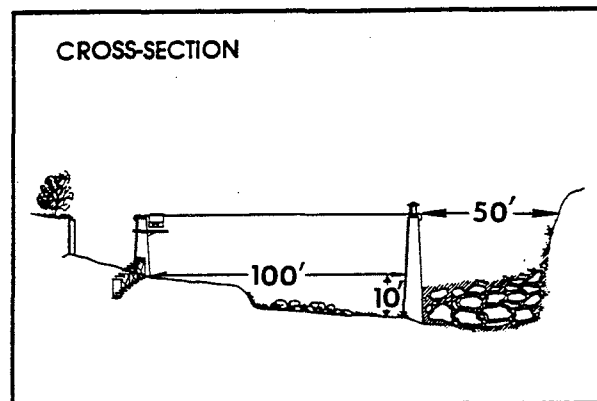
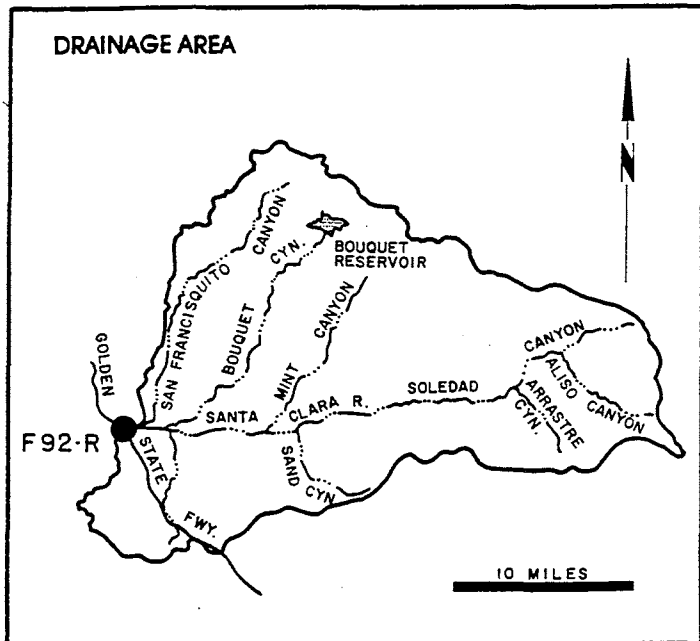
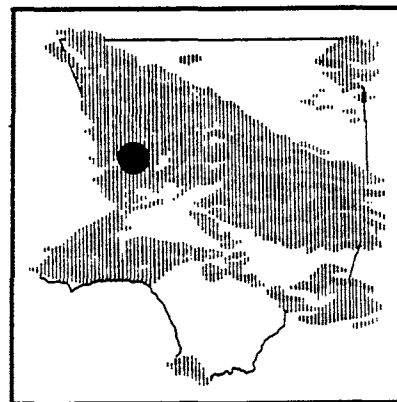

RECORDER- continuous water stage.

METHOD OF MEASUREMENTS- wading or from cable car.

DRAINAGE AREA- 410.4 square miles.

LOCATION- downstream side of Old Highway bridge, 3.0 miles west of Saugus.

REGULATION- partially regulated by Bouquet Canyon and Dry Canyon Reservoirs.

CHANNEL- sand and gravel with brush, natural section.

CONTROL- none.

LENGTH OF RECORD- at Station F92-R January 18, 1930 to March 28, 1938, and September 24, 1956 to date. at Station F92B-R, October 1, 1938 to September 24, 1956.

REMARKS- subject to diversions for irrigation.

WATER YEAR 1992-1993

(DISCHARGE IN CFS)

STATION NO.: F92C-R

DRAINAGE AREA: 410.40 SQ. MI.

MONTH	OCT	NOV	DEC	JAN	FEB	MAR	APR	MAY	JUN	JUL	AUG	SEP
MEAN				658.0	592.0	134.0	61.5	31.0	12.9			
MAX.	RECORDER INOPERATIVE			1,460.0	3,500.0	200.0	76.1	46.0	16.6	RECORDER INOPERATIVE		
MIN.				27.3	6.4	76.1	47.0	16.0	10.6			
TOTAL AF				40,460.0	32,850.0	8,253.0	3,660.0	1,906.0	770.0			

PALLETT CREEK at Valyermo Highway STATION NO. F122-R

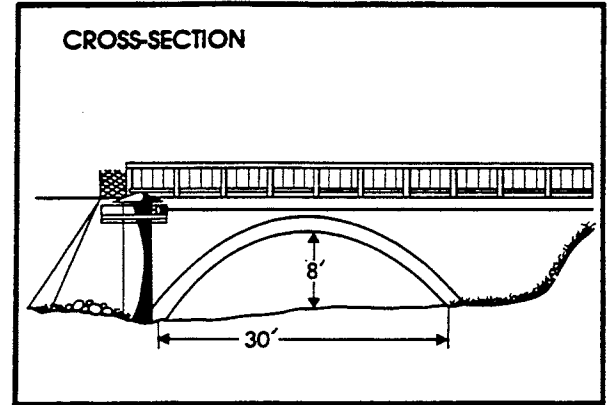
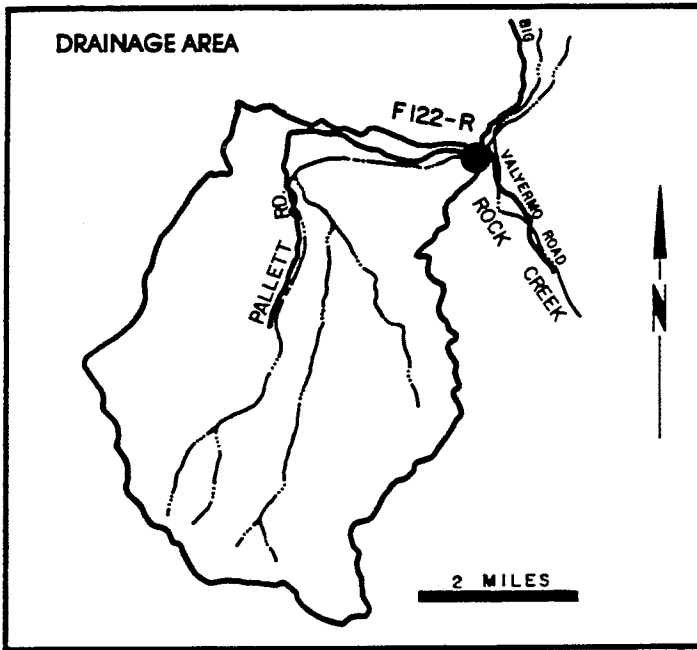
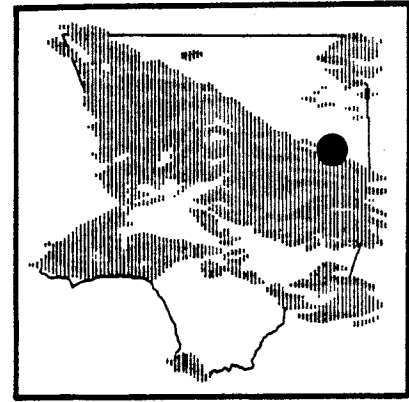

RECORDER- continuous water stage.

METHOD OF MEASUREMENTS- wading or from bridge.

DRAINAGE AREA- 15.8 square miles.

LOCATION- upstream side of Valyermo Highway bridge, 5.0 miles southeast of Pearblossom.

REGULATION- none.

CHANNEL- sand and gravel, natural section.

CONTROL- channel forms control for low flows; bridge culvert forms control for high flows.

LENGTH OF RECORD- at Station F122-S December 29, 1930 to October 31, 1961. at Station F122-R, October 31, 1961 to date.

WATER YEAR 1992-1993 (DISCHARGE IN CFS)

STATION NO. : F122-R

DRAINAGE AREA : 15.8 SQ. MI.

MONTH	OCT	NOV	DEC	JAN	FEB	MAR	APR	MAY	JUN	JUL	AUG	SEP
MEAN	1.1	1.5	7.0	11.0	106.0	22.7	19.6	8.5	6.3	2.9	1.8	1.5
MAX.	1.6	2.0	11.3	45.3	498.0	81.9	60.6	10.4	10.5	4.0	2.0	1.5
MIN.	0.4	0.9	2.0	5.8	5.0	6.9	5.0	5.7	4.0	2.0	1.5	1.3
TOTAL AF	69.0	89.0	433.0	676.0	5,875.0	1,396.0	1,167.0	523.0	375.0	181.0	111.0	87.0

SANTIAGO CREEK above Little Rock Creek STATION NO. F125-R

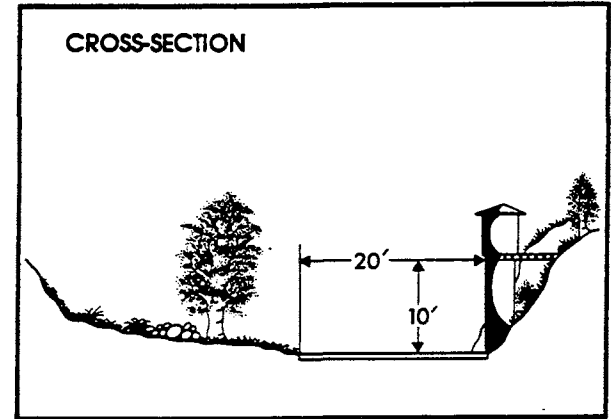
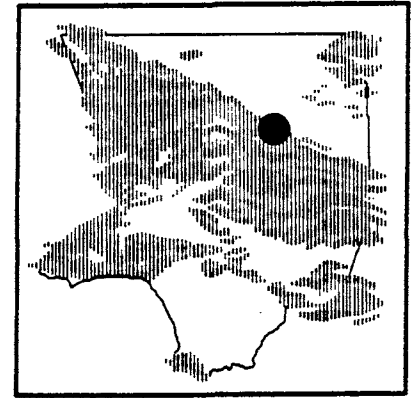
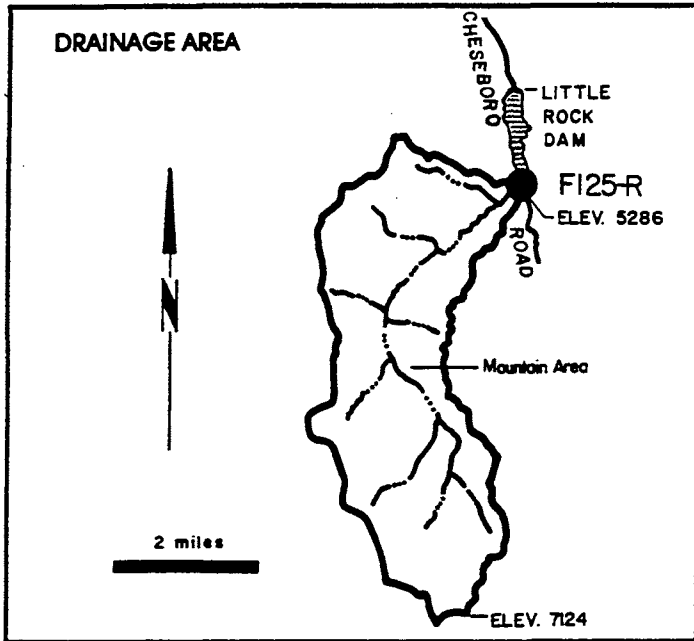

RECORDER- continuous water stage.
METHOD OF MEASUREMENTS- wading.
DRAINAGE AREA- 11.2 square miles.
LOCATION- 1,000 feet above Little Creek and 4.5 miles south of Little Rock.
REGULATION- none.
CHANNEL- sand, gravel and boulders.
CONTROL- concrete and rubble wall.
LENGTH OF RECORD- September 29, 1953 to date.
REMARKS- no high flow measurements.

WATER YEAR 1992-1993 (DISCHARGE IN CFS)

STATION NO. : F125-R

DRAINAGE AREA : 11.20 SQ. MI.

MONTH	OCT	NOV	DEC	JAN	FEB	MAR	APR	MAY	JUN	JUL	AUG	SEP
MEAN	0.0	0.0	0.1	20.0	32.3	7.9	7.0	3.0	2.1	0.4	0.0	0.0
MAX.	0.0	0.0	1.4	59.6	177.0	23.2	14.5	4.1	3.0	1.1	0.1	0.0
MIN.	0.0	0.0	0.0	0.0	8.6	3.2	3.0	2.3	0.7	0.1	0.0	0.0
TOTAL AF	0.0	0.0	3.0	1,231.0	1,796.0	485.0	416.0	187.0	123.0	22.0	2.0	0.0

MALIBU CREEK below Cold Creek STATION NO. F130-R

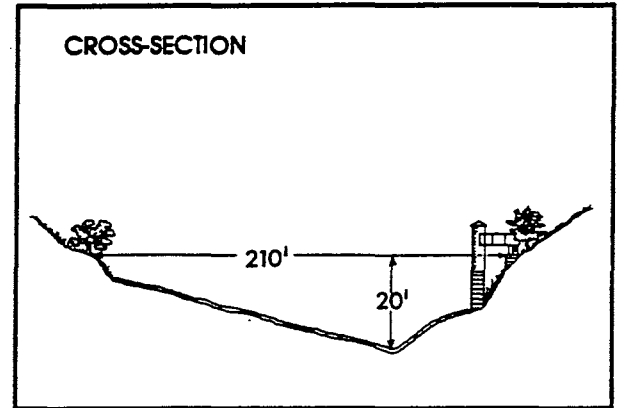
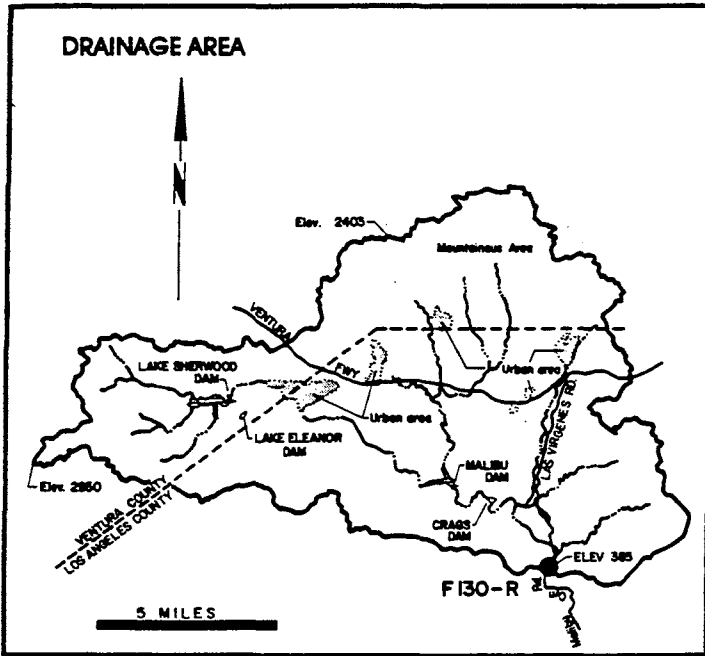
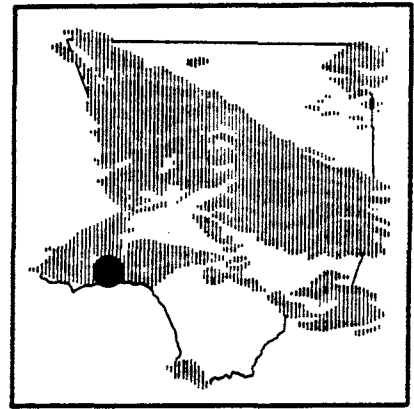

RECORDER- continuous water stage.

METHOD OF MEASUREMENTS- wading or from cable car.

DRAINAGE AREA- 104.96 square miles

LOCATION- 0.2± mile downstream of Cold Creek, 6.0 miles southwest of Calabasas.

REGULATION- Lake Sherwood Dam, Lake Eleanor Dam, Malibu Lake Dam, and Crag's Dam. Other small recreational dams affect low summer flows.

CHANNEL- coarse sand and gravel, lined with trees and brush, natural in section.

CONTROL- concrete stabilizer.

LENGTH OF RECORD- January 17, 1931 to date.

REMARKS- cableway washed out on January 25, 1969; no high flow measurements since that date.

WATER YEAR 1992-1993 (DISCHARGE IN CFS)

STATION NO.: F130-R

DRAINAGE AREA: 104.96 SQ. MI.

MONTH	OCT	NOV	DEC	JAN	FEB	MAR	APR	MAY	JUN	JUL	AUG	SEP
MEAN	8.6	9.3			440.0	187.0	68.0	45.0	24.0	14.1	4.7	6.3
MAX	29.5	13.1	NO RECORDS		1,820.0	800.0	130.0	61.4	77.0	21.1	9.5	11.9
MIN	3.5	7.2			45.4	65.9	46.0	23.2	10.6	8.2	2.2	2.3
TOTAL AF	528.0	551.0			24,450.0	11,510.0	4,044.0	2,766.0	1,426.0	868.0	288.0	376.0

MONTEBELLO STORM DRAIN

above Rio Hondo

STATION NO. F181-R

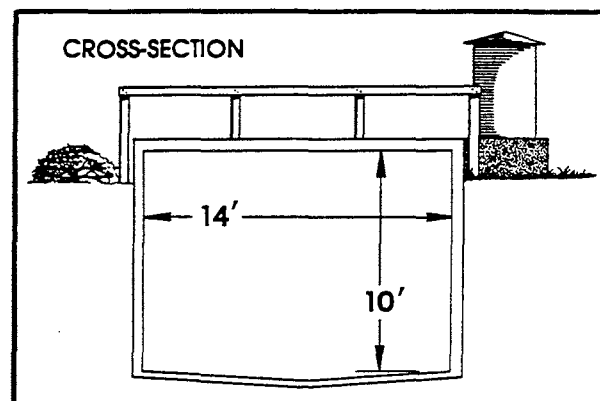
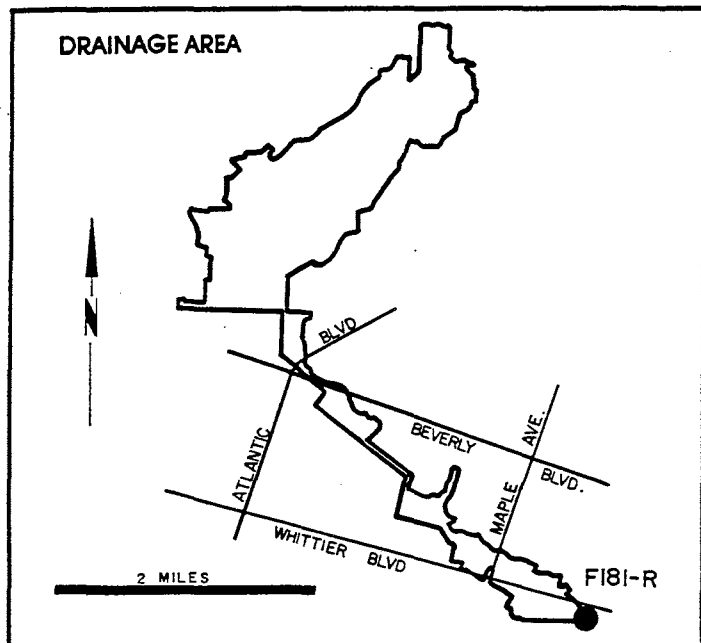
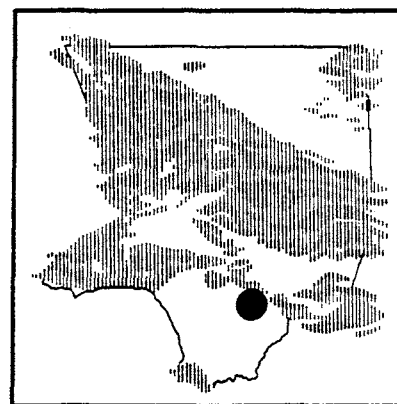

RECORDER- continuous water stage.
METHOD OF MEASUREMENTS- wading or from footbridge.
DRAINAGE AREA- 9.6 square miles.
LOCATION- 150.0 feet east of Mines Avenue and 500.0 feet west of Rio Hondo.
REGULATION- none.
CHANNEL- 14.0-foot by 10.0-foot concrete, box section.
CONTROL- channel forms control.
LENGTH OF RECORD- January 12, 1932 to date.
REMARKS- may be affected by backwater during flood flows.

WATER YEAR 1992-1993 (DISCHARGE IN CFS)

STATION NO.: F181-R

DRAINAGE AREA : 9.60 SQ. MI.

MONTH	OCT	NOV	DEC	JAN	FEB	MAR	APR	MAY	JUN	JUL	AUG	SEP
MEAN	0.9	0.3	8.4	27.3	16.0	2.0	0.1	0.2	0.7	0.1	0.1	0.2
MAX.	15.7	0.4	186.0	204.0	153.0	26.8	0.3	0.4	16.1	0.3	0.3	0.6
MIN.	0.2	0.2	0.2	0.4	0.3	0.2	0.0	0.0	0.0	0.0	0.0	0.1
TOTAL AF	54.0	18.0	518.0	1,678.0	889.0	123.0	8.0	12.0	40.0	6.0	8.0	10.0

SAN GABRIEL RIVER at Foothill Boulevard STATION NO. F190-R

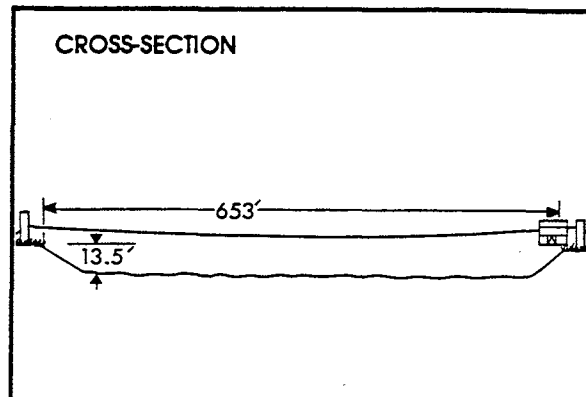
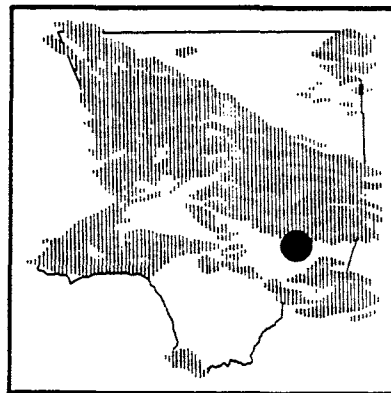
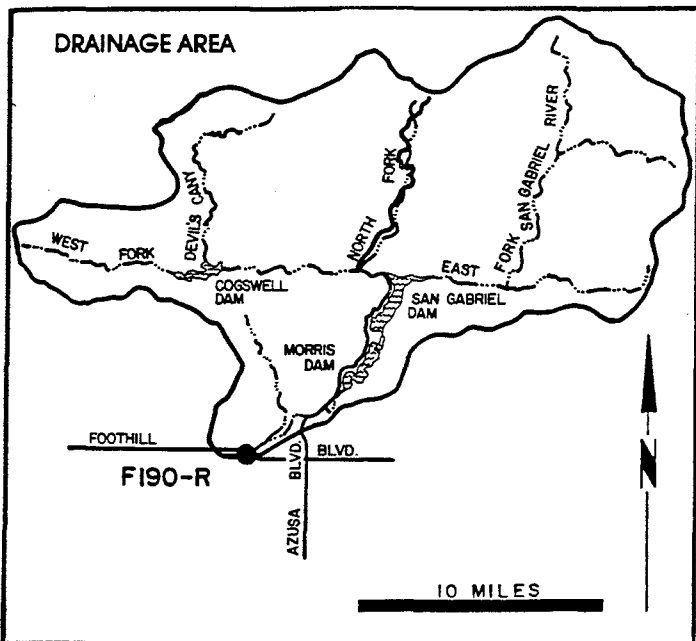

RECORDER- continuous water stage.

METHOD OF MEASUREMENTS- wading or from cable car.

DRAINAGE AREA- 230.0 square miles.

LOCATION- downstream side of Foothill Boulevard bridge, 2.0 miles west of Azusa.

REGULATION- partially regulated by Cogswell, San Gabriel, and Morris Dams.

CHANNEL- sand, gravel and rock, trapezoidal section with soft bottom.

CONTROL- gunited rock stabilizers.

LENGTH OF RECORD- February 22, 1932 to date.

REMARKS- flows may include imported water originating at the Metropolitan Water District outlet below Morris Dam.

WATER YEAR 1992-1993 (DISCHARGE IN CFS)

STATION NO. : F190-R

DRAINAGE AREA : 230.00 SQ. MI.

MONTH	OCT	NOV	DEC	JAN	FEB	MAR	APR	MAY	JUN	JUL	AUG	SEP
MEAN	134.0	191.0	165.0	2,049.0	2,466.0	670.0	632.0	353.0	167.0	166.0	155.0	163.0
MAX.	330.0	312.0	316.0	8,600.0	8,520.0	1,360.0	756.0	573.0	321.0	218.0	310.0	311.0
MIN.	49.7	134.0	69.6	20.4	369.0	4.7	527.0	14.0	4.2	6.3	0.0	0.0
TOTAL AF	8,233.0	11,360.0	10,170.0	126,000.0	137,000.0	41,210.0	37,580.0	21,720.0	9,929.0	10,210.0	9,502.0	9,722.0

RIO HONDO

below Lower Azusa Road

STATION NO. F192B-R

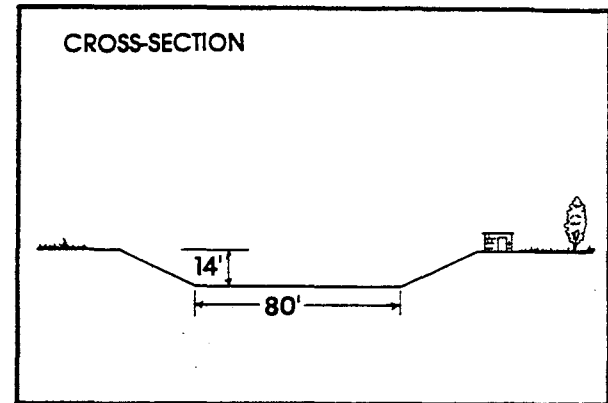
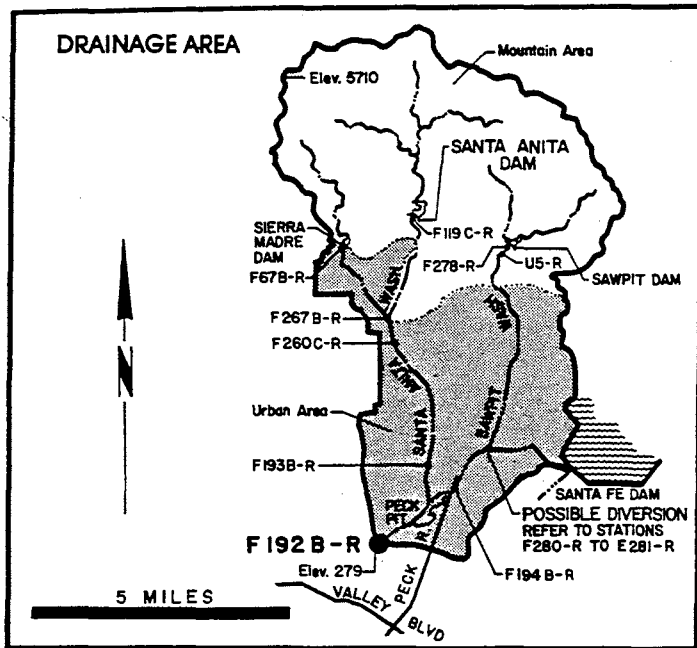
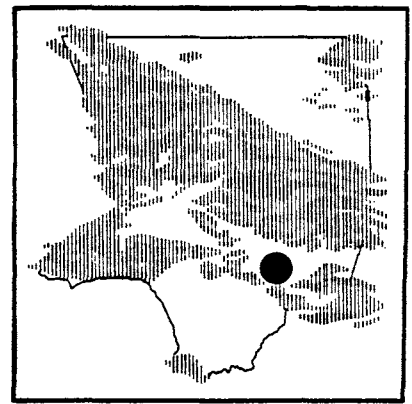

RECORDER- continuous water stage.

METHOD OF MEASUREMENTS- wading.

DRAINAGE AREA- 40.9 square miles (excludes area above Santa Fe Dam).

LOCATION- 300.0 feet downstream from Lower Azusa Road, 1.5 miles north of El Monte.

REGULATION- partially regulated by Sierra Madre Dam, Santa Anita Dam, Sawpit Dam, Santa Fe Dam, Peck Pit, Buena Vista Pit, and several debris basins.

CHANNEL- concrete, trapezoidal in section.

CONTROL- channel forms control.

LENGTH OF RECORD- at Station F192-R February 22, 1932 to May 7, 1958. at Station F192B-R May 7, 1958 to date.

REMARKS- subject to diversions from Monrovia, Sawpit, and Little Santa Anita Creeks. Also from the San Gabriel River below Santa Fe Dam; and for irrigation and spreading.

WATER YEAR 1992-1993

(DISCHARGE IN CFS)

STATION NO. : F192B-R

DRAINAGE AREA : 40.90 SQ. MI.

MONTH	OCT	NOV	DEC	JAN	FEB	MAR	APR	MAY	JUN	JUL	AUG	SEP
MEAN	43.6	17.5	6.2	205.0	191.0	90.4	32.2	1.6	69.0	64.8	61.2	12.8
MAX	169.0	133.0	79.0	1,010.0	984.0	271.0	59.8	7.1	119.0	97.5	151.0	48.3
MIN	0.0	0.0	0.0	0.1	0.6	27.0	0.1	0.0	0.8	0.7	0.7	0.4
TOTAL AF	2,682.0	1,041.0	382.0	12,590.0	10,590.0	5,561.0	1,914.0	101.0	4,104.0	3,986.0	3,765.0	761.0

SANTA ANITA WASH

at Longden Avenue

STATION NO. F193B-R

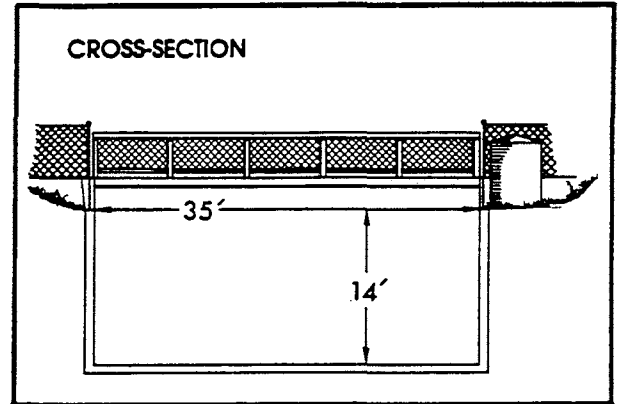
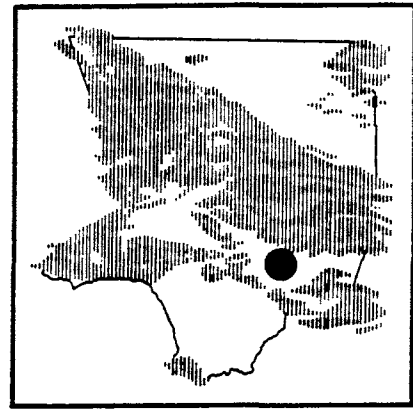
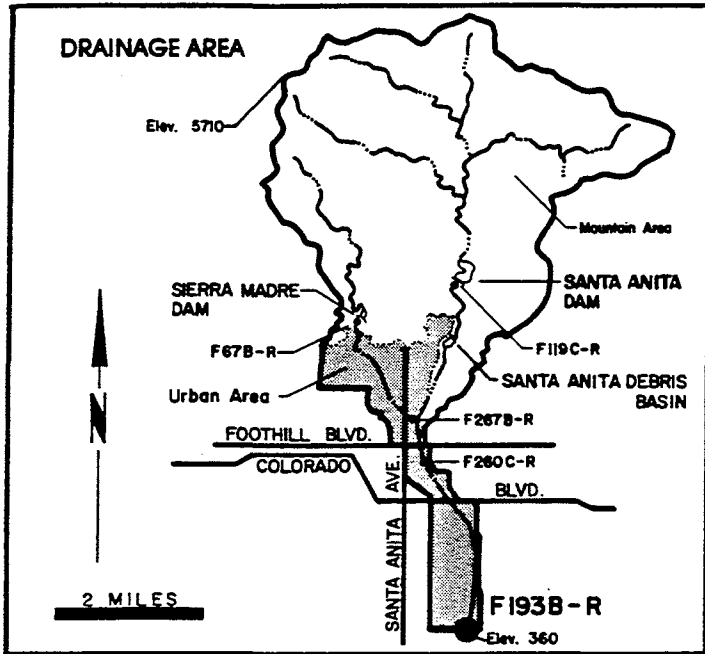

RECORDER - continuous water stage.

METHOD OF MEASUREMENTS- wading or from bridge.

DRAINAGE AREA- 18.8 square miles.

LOCATION - 30.0 feet above Longden Avenue, 1.5 miles south of Arcadia.

REGULATION - regulated by Santa Anita and Sierra Madre Dams, and Santa Anita Debris Basin.

CHANNEL - concrete rectangular section.

CONTROL- channel forms control.

LENGTH OF RECORD- at Station F193-R, April 25, 1932 to March 1, 1938. at Station F193B-R, January 5, 1960 to date.

WATER YEAR 1992-1993

(DISCHARGE IN CFS)

STATION NO. : F193B-R

DRAINAGE AREA : 18.80 SQ. MI.

MONTH	OCT	NOV	DEC	JAN	FEB	MAR	APR	MAY	JUN	JUL	AUG	SEP
MEAN	2.0	0.1	10.3	161.0	144.0	73.7	27.2	8.4	3.9	4.2	0.0	0.7
MAX.	47.7	0.9	157.0	552.0	350.0	238.0	59.7	22.6	45.4	12.8	0.3	3.0
MIN.	0.0	0.0	0.0	2.3	46.0	1.2	0.0	0.0	0.0	0.0	0.0	0.0
TOTAL AF	124.0	4.0	634.0	9,890.0	8,002.0	4,529.0	1,618.0	516.0	232.0	260.0	1.0	44.0

SAWPIT WASH

below Live Oak Avenue
STATION NO. F194B-R

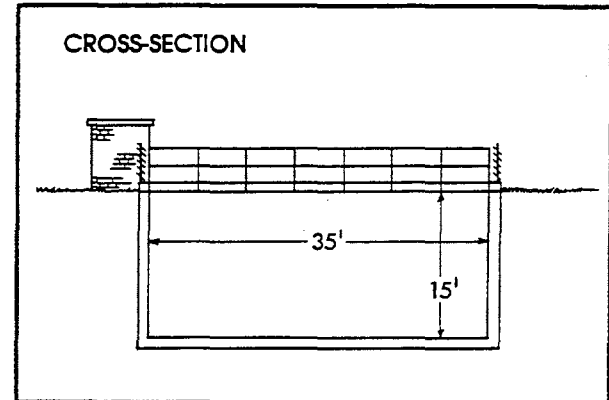
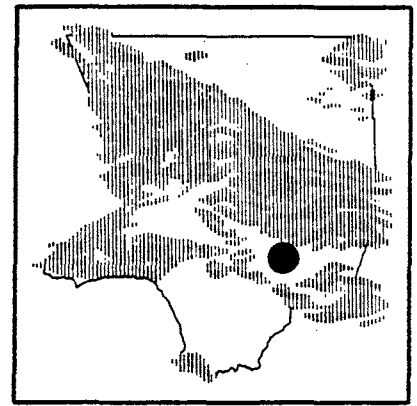
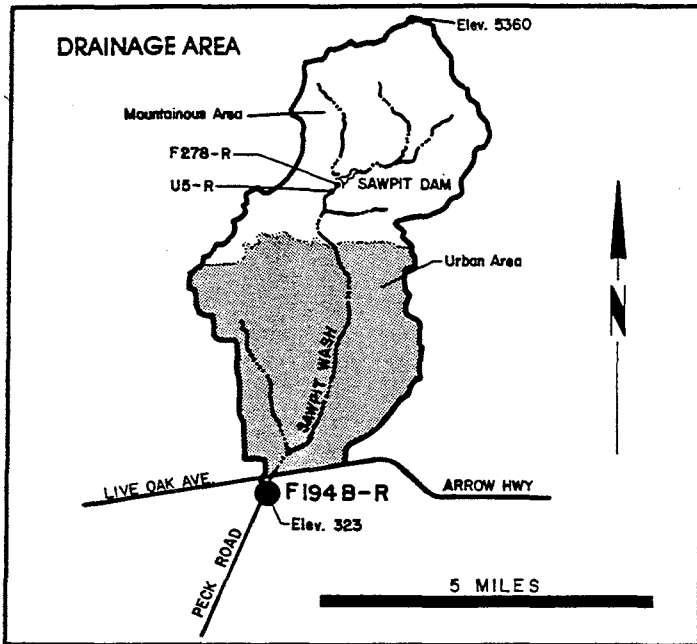

RECORDER- continuous water stage.

METHOD OF MEASUREMENTS- wading or from footbridge.

DRAINAGE AREA- 16.1 square miles.

LOCATION- 1,500 feet below Arrow Highway, 3.0 miles south of Monrovia.

REGULATION- partially regulated by Sawpit and Santa Fe Dams, and by several debris basins.

CHANNEL- concrete, rectangular section.

CONTROL- channel forms control.

LENGTH OF RECORD- at Station F194-R February 22, 1932 to September 1, 1935. at Station F194B-R December 5, 1960 to date.

WATER YEAR 1992-1993 (DISCHARGE IN CFS)

STATION NO. : F194B-R

DRAINAGE AREA : 16.10 SQ. MI.

MONTH	OCT	NOV	DEC	JAN	FEB	MAR	APR	MAY	JUN	JUL	AUG	SEP
MEAN	60.7	15.3	15.5	61.1	48.5	47.1	41.0	9.6	67.7	73.2	58.6	10.1
MAX.	183.0	98.8	289.0	318.0	352.0	94.5	57.6	25.4	128.0	98.3	139.0	60.0
MIN.	0.0	0.0	0.0	0.3	2.0	7.0	12.7	0.7	0.5	4.5	0.2	0.0
TOTAL AF	3,730.0	908.0	950.0	3,755.0	2,696.0	2,897.0	2,441.0	588.0	4,027.0	4,500.0	3,602.0	600.0

SAN GABRIEL-AZUSA CONDUIT

at 25 ft. Weir below San Gabriel Dam

STATION NO. F250-R

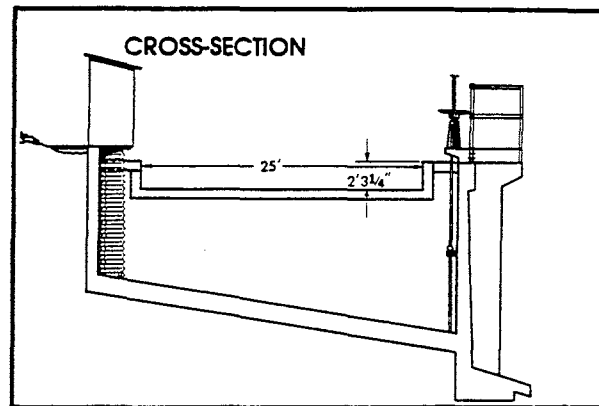
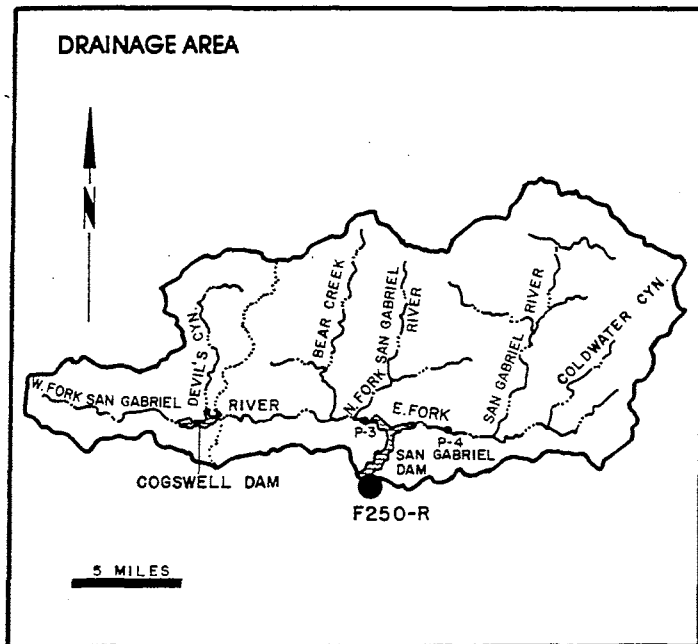
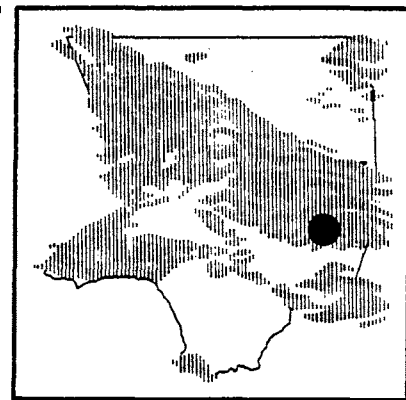

RECORDER- continuous water stage.
 METHOD OF MEASUREMENTS- weir formula with gage height observation.
 DRAINAGE AREA- none.
 LOCATION- on the concrete conduit which diverts from San Gabriel Dam, 160 feet below the Dam.
 REGULATION- regulated in section.
 CONTROL- 25-foot concrete weir.
 LENGTH OF RECORD- February 26, 1933, to date.
 REMARKS- approximate capacity 95 second-feet.

WATER YEAR 1992-1993 (DISCHARGE IN CFS)

STATION NO. : F250-R

DRAINAGE AREA : NONE SQ. MI.

MONTH	OCT	NOV	DEC	JAN	FEB	MAR	APR	MAY	JUN	JUL	AUG	SEP
MEAN	0.0	0.0	0.0	13.3	53.0	66.9	68.7	77.3	77.3	78.4	81.8	81.4
MAX.	0.0	0.0	0.0	53.1	83.7	83.2	79.4	79.5	77.9	81.1	84.0	82.5
MIN.	0.0	0.0	0.0	0.0	0.0	13.8	57.5	70.2	76.5	74.1	79.9	79.9
TOTAL AF	0.0	0.0	0.0	818.0	2,941.0	4,113.0	4,090.0	4,755.0	4,602.0	4,820.0	5,030.0	4,842.0

VERDUGO WASH at Estelle Avenue STATION NO. F252-R

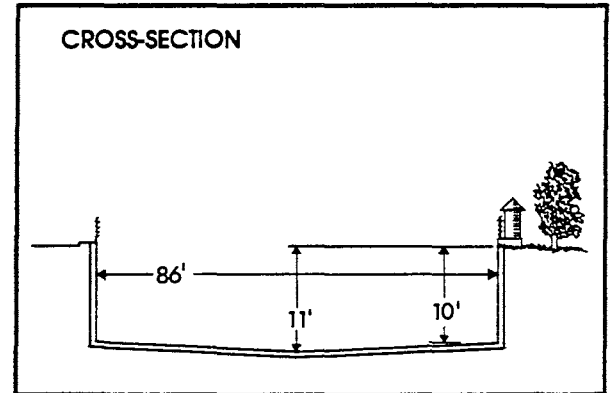
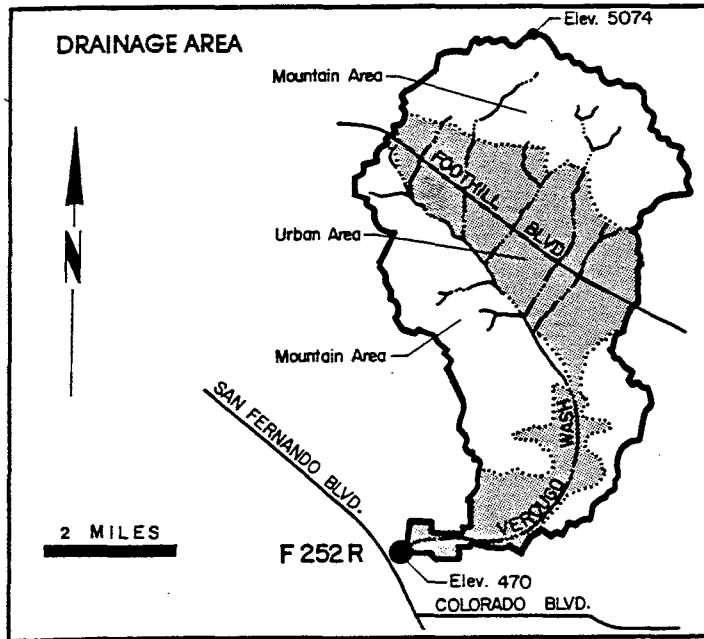
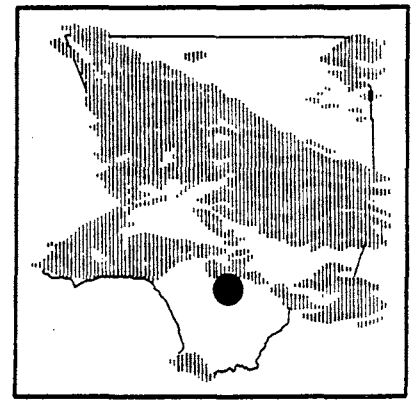

RECORDER- continuous water stage.
METHOD OF MEASUREMENTS- wading or from Concord Street Bridge.
DRAINAGE AREA- 26.8 square miles.
LOCATION- 800.0 feet east of San Fernando Road, 2.0 miles northwest of Glendale.
REGULATION- partially regulated by several debris basins.
CHANNEL- concrete, rectangular in section.
CONTROL- channel forms control.
LENGTH OF RECORD- December 2, 1935 to date.

WATER YEAR 1992-1993 (DISCHARGE IN CFS)

STATION NO.: F252-R

DRAINAGE AREA: 26.80 SQ. MI.

MONTH	OCT	NOV	DEC	JAN	FEB	MAR	APR	MAY	JUN	JUL	AUG	SEP
MEAN	15.6	2.7	41.8	146.0	122.0	28.2	8.0	9.8	11.1	3.7	3.3	3.3
MAX	363.0	4.3	548.0	733.0	675.0	333.0	10.5	11.7	216.0	5.6	6.2	6.2
MIN	2.3	2.3	1.7	3.2	6.2	7.2	7.2	6.3	2.5	2.3	1.7	2.3
TOTAL AF	960.0	158.0	2,573.0	8,966.0	6,759.0	1,735.0	478.0	601.0	660.0	230.0	202.0	198.0

SAN GABRIEL RIVER

below Valley Boulevard

STATION NO. F261C-R

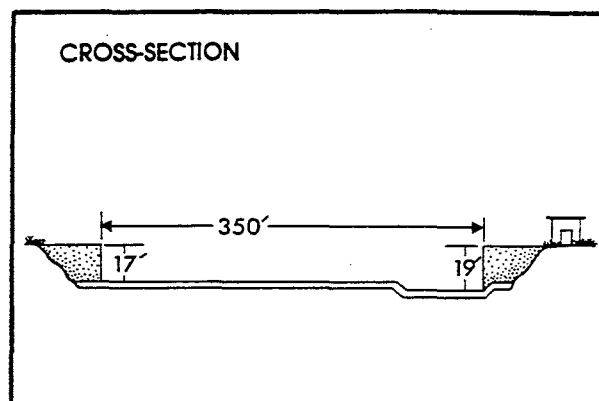
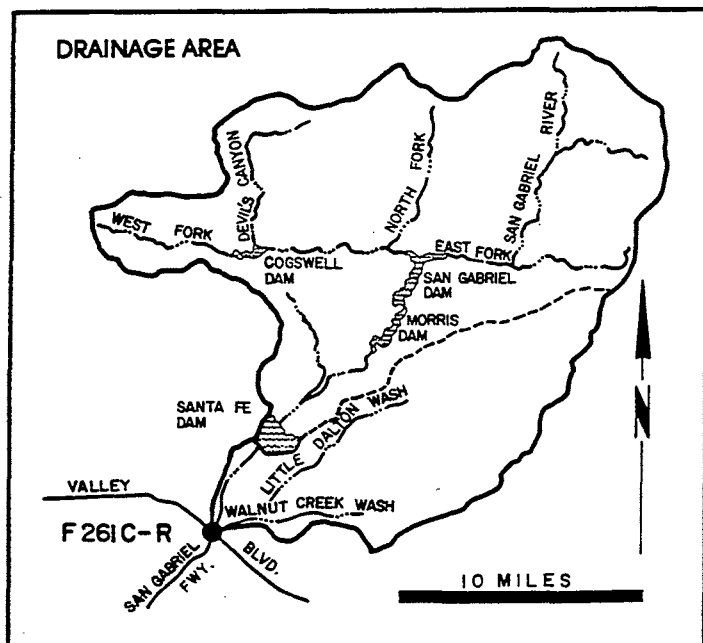
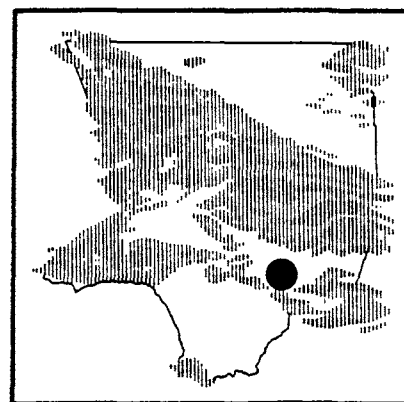

RECORDER- continuous water stage.

METHOD OF MEASUREMENTS- wading.

DRAINAGE AREA- 118.0 square miles (excludes area above Santa Fe Dam).

LOCATION- 1,150.0 feet below Valley Boulevard, 2.5 miles east of El Monte.

REGULATION- partly regulated by Santa Fe, Big Dalton, Puddingstone Diversion, and Puddingstone Dams.

CHANNEL- sand and gravel bottom with rip-rap side slopes; trapezoidal section.

CONTROL- concrete stabilizer with low-flow notch.

LENGTH OF RECORD- at Station F261-R March 11, 1937 to September 30, 1941. at Station F261B-R October 1, 1941 to April 23, 1946. at Station F261C-R November 29, 1960 to date.

REMARKS- flows may include imported water originating at Metropolitan Water District outlets at San Dimas Canyon and below San Bernardino Road.

WATER YEAR 1992-1993

(DISCHARGE IN CFS)

STATION NO. : F261C-R

DRAINAGE AREA : 118.00 SQ. MI.

MONTH	OCT	NOV	DEC	JAN	FEB	MAR	APR	MAY	JUN	JUL	AUG	SEP
MEAN	71.8	33.4	121.0	2,308.0	2,542.0	418.0	75.7	50.2	20.8	1.3	3.3	0.9
MAX.	487.0	58.1	1,700.0	10,400.0	8,840.0	2,050.0	206.0	93.0	447.0	5.8	17.8	2.0
MIN.	0.0	0.0	0.0	36.7	123.0	70.2	11.6	0.7	0.0	0.0	0.0	0.0
TOTAL AF	4,413.0	1,988.0	7,461.0	141,900.0	141,200.0	25,700.0	4,502.0	3,087.0	1,235.0	82.0	201.0	52.0

SAN GABRIEL RIVER above Florence Avenue STATION NO. F262C-R

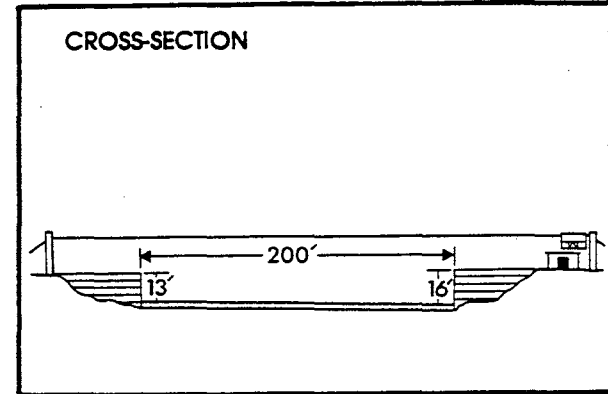
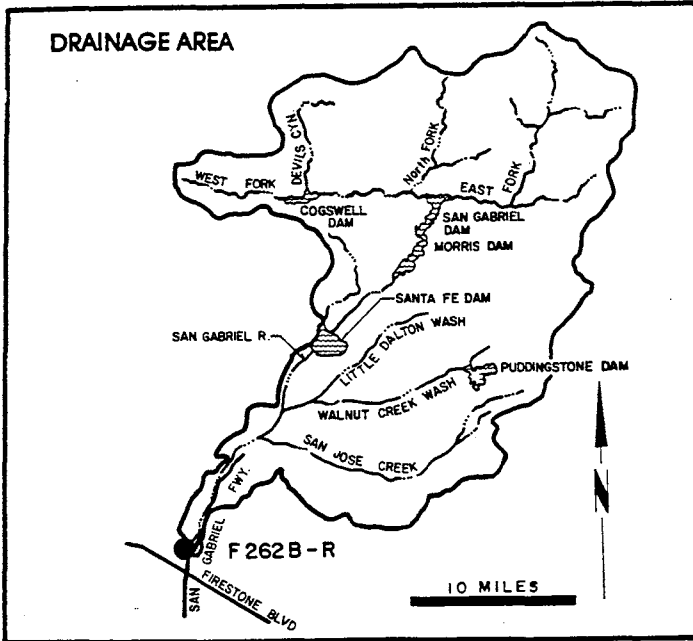
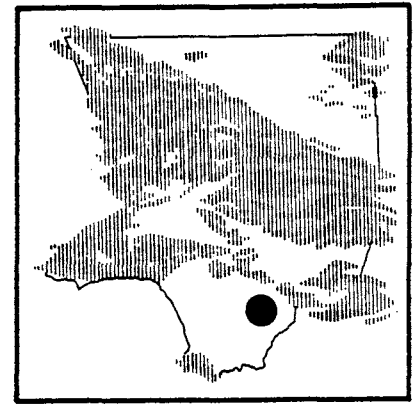

RECORDER- continuous water stage.

METHOD OF MEASUREMENTS- wading or from cable car.

DRAINAGE AREA- 215.8 square miles (excludes area above Santa Fe Dam).

LOCATION- 1,400 feet above Florence Avenue, 2.0 miles east of Downey.

REGULATION- partially regulated by Cogswell, San Gabriel, Morris, Santa Fe, Big Dalton, San Dimas, Puddingstone Diversion, Puddingstone, Live Oak, Thompson Creek and Whittier Narrows Dams, several debris basins, MWD outlets, and several spreading grounds.

CHANNEL- sand bottom with rip-rap slopes, trapezoidal section.

CONTROL- concrete stabilizer.

LENGTH OF RECORD- at Station F267-R February 27, 1937 to September 30, 1967. at Station F262B-R August 6, 1968 to date.

REMARKS- no record during 1967-1968 season due to channel construction.

WATER YEAR 1992-1993 (DISCHARGE IN CFS)

STATION NO. : F262C-R

DRAINAGE AREA : 215.8 SQ. MI.

MONTH	OCT	NOV	DEC	JAN	FEB	MAR	APR	MAY	JUN	JUL	AUG	SEP
MEAN	0.0	0.6	23.0	1,799.0	1,120.0	409.0	1.5	0.0	0.0	0.0	0.0	0.0
MAX.	0.0	18.4	669.0	6,990.0	4,170.0	2,790.0	41.4	0.0	0.0	0.0	0.0	0.0
MIN.	0.0	0.0	0.0	0.0	0.0	0.0	0.0	0.0	0.0	0.0	0.0	0.0
TOTAL AF	0.0	36.0	1,414.0	110,600.0	62,210.0	25,150.0	87.0	0.0	0.0	0.0	0.0	0.0

SAN GABRIEL RIVER

below San Gabriel River Parkway

STATION NO. F263C-R

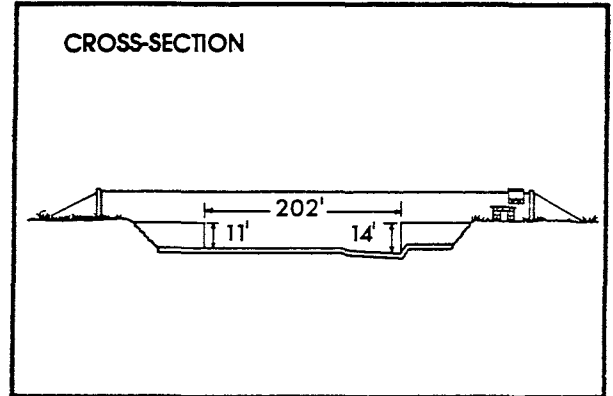
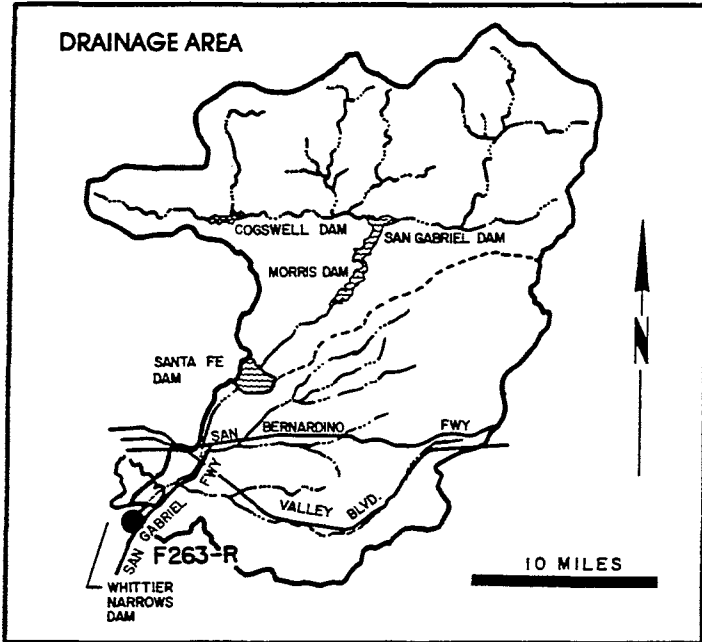
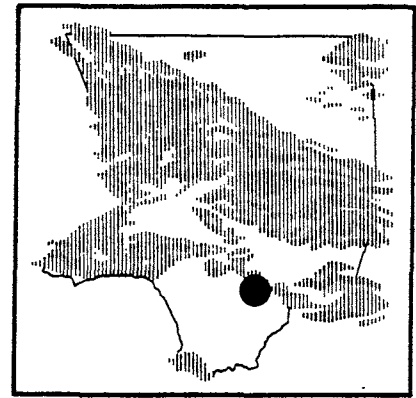

RECORDER- continuous water stage.

METHOD OF MEASUREMENTS- wading or from cable car.

DRAINAGE AREA- 206.3 square miles (excludes area above Santa Fe Dam).

LOCATION- 462.0 feet below San Gabriel River Parkway, 1.4 miles northeast of Pico Rivera.

REGULATION- partly regulated by Santa Fe, Big Dalton, Puddingstone Diversion, Puddingstone, and Thompson Creek Dams. Flows may include imported water from several Metropolitan Water District outlets. Water is at times diverted to the Zone I ditch upstream of Whittier Narrows Dam.

CHANNEL- rip-rap slopes with sand bottom trapezoidal section.

CONTROL- concrete stabilizer.

LENGTH OF RECORD - at Station F263-R February 4, 1937 to March 6, 1952. at Station F263B-R March 6, 1952 to August 9, 1968. at Station F263C-R August 9, 1968 to date.

WATER YEAR 1992-1993

(DISCHARGE IN CFS)

STATION NO. : F263C-R

DRAINAGE AREA : 206.30 SQ. MI.

MONTH	OCT	NOV	DEC	JAN	FEB	MAR	APR	MAY	JUN	JUL	AUG	SEP
MEAN	24.1	51.7	121.0	2,110.0	1,459.0	555.0	60.6	48.0	70.6	38.1	27.9	24.3
MAX.	589.0	135.0	1,270.0	6,460.0	5,050.0	3,080.0	109.0	92.0	634.0	82.3	61.2	55.5
MIN.	0.0	0.0	0.0	43.6	72.6	73.2	32.0	17.8	18.2	5.0	3.1	4.8
TOTAL AF	1,480.0	3,076.0	7,464.0	129,800.0	81,010.0	34,150.0	3,606.0	2,954.0	4,203.0	2,341.0	1,716.0	1,446.0

DALTON WASH at Merced Avenue STATION NO. F274B-R

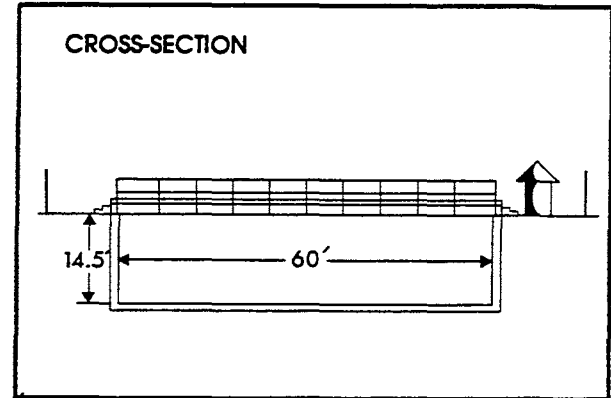
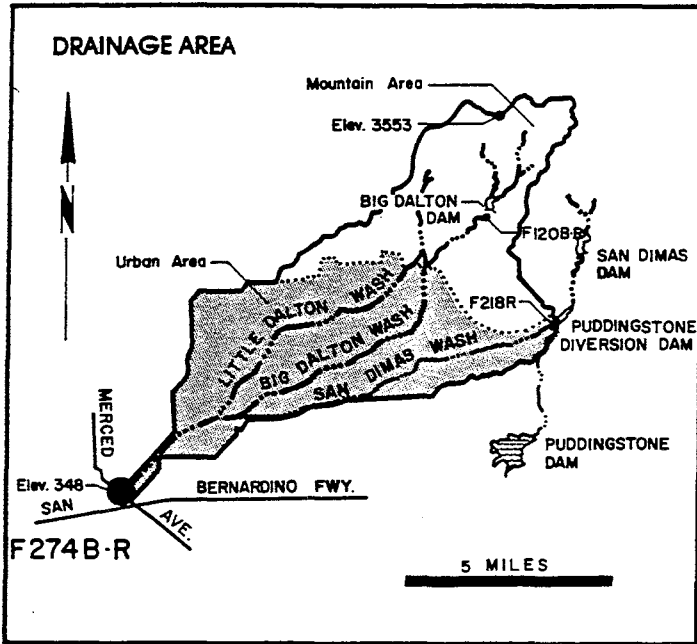
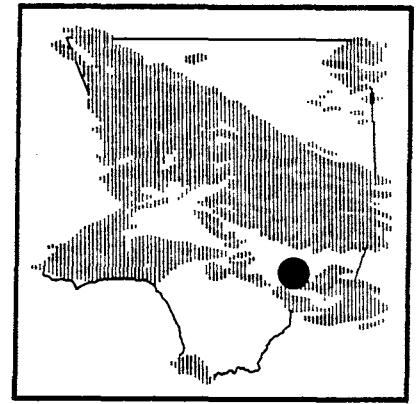

RECORDER- 15 minute punched tape.

METHOD OF MEASUREMENTS- low flows measured by wading. High flows measured from footbridge 100 feet upstream from station.

DRAINAGE AREA- 36.0 square miles, not including the area above Puddingstone Diversion Dam.

LOCATION- on the west bank and upstream of Merced Avenue about 150 feet, about one-half mile above the junction with Walnut Wash and about one mile south of Baldwin Park.

REGULATION- partly regulated by Big Dalton Dam, San Dimas Dam, Puddingstone Diversion Dam, Big Dalton Spreading Grounds, Little Dalton Spreading Grounds, Big Dalton Debris Basin, Little Dalton Debris Basin, and Irwindale Spreading Grounds.

REMARKS- flow may include imported water originating at San Dimas.

WATER YEAR 1992-1993 (DISCHARGE IN CFS)

STATION NO. : F274B-R

DRAINAGE AREA : 36.00 SQ. MI.

MONTH	OCT	NOV	DEC	JAN	FEB	MAR	APR	MAY	JUN	JUL	AUG	SEP
MEAN	52.1	35.4	78.8	153.0	78.7	8.5	4.3	11.5	12.5	4.0	6.9	8.7
MAX.	154.0	58.1	660.0	790.0	557.0	145.0	17.3	36.3	242.0	6.5	15.7	11.8
MIN.	0.0	0.5	0.1	0.0	0.0	0.1	0.1	0.1	0.2	2.1	3.0	4.7
TOTAL AF	3,201.0	2,106.0	4,847.0	9,418.0	4,370.0	525.0	258.0	707.0	745.0	247.0	425.0	518.0

SANTA FE CHANNEL

below Santa Fe Dam

STATION NO. F280-R

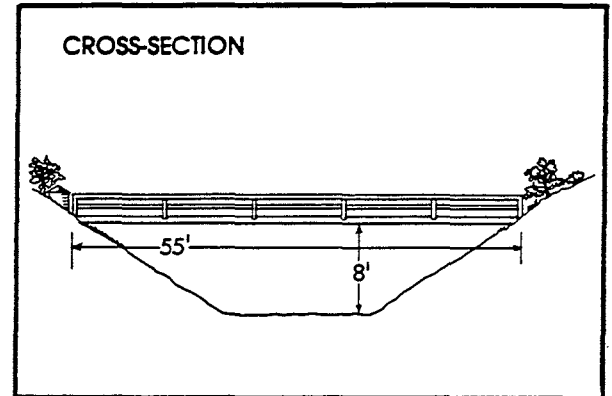
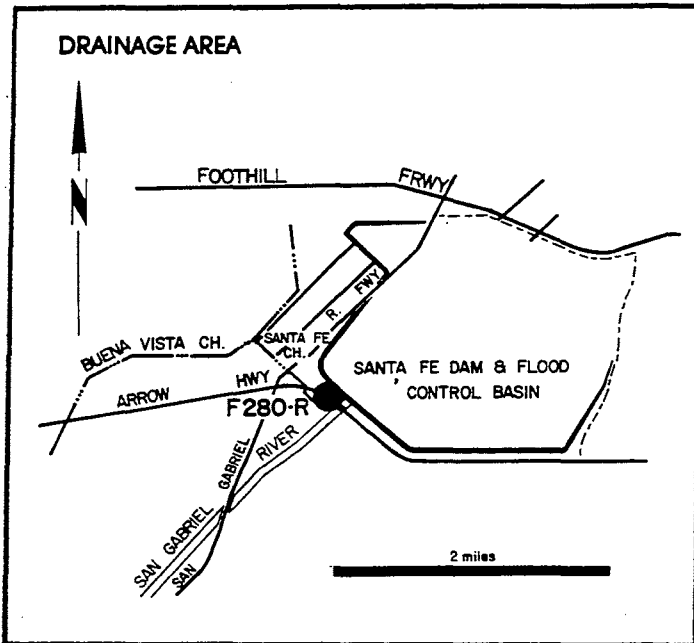
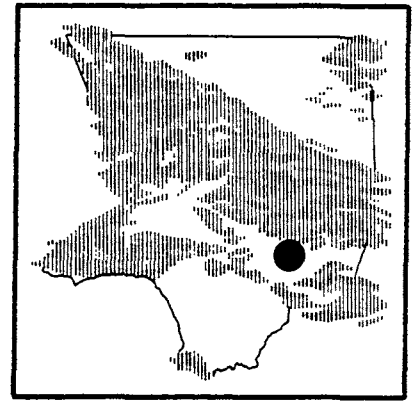

RECORDER- continuous water stage.
 METHOD OF MEASUREMENTS- wading or from footbridge.
 DRAINAGE AREA- controlled.
 LOCATION- 400.0 feet downstream of Santa Fe Dam outlet and 1.5 miles north of Baldwin Park.
 REGULATION- flow regulated by five gates of stilling basin outlet of Santa Fe Dam.
 CHANNEL- sand and gravel, natural section.
 CONTROL- concrete stabilizer.
 LENGTH OF RECORD- at Station F280-S October 1, 1942 to May 12, 1944. at Station F280-R May 12, 1944 to date.

WATER YEAR 1992-1993

(DISCHARGE IN CFS)

STATION NO. : F280-R

DRAINAGE AREA : CONTROLLED

MONTH	OCT	NOV	DEC	JAN	FEB	MAR	APR	MAY	JUN	JUL	AUG	SEP
MEAN	97.4	26.1	0.0	0.1	0.1	60.4	40.9	3.8	87.4	89.3	78.8	15.1
MAX.	181.0	170.0	0.8	1.5	3.7	165.0	62.1	12.5	193.0	125.0	168.0	97.1
MIN.	0.0	0.0	0.0	0.0	0.0	0.0	8.3	0.0	0.0	0.0	0.0	0.0
TOTAL AF	5,989.0	1,555.0	2.0	6.0	8.0	3,714.0	2,431.0	231.0	5,200.0	5,493.0	4,847.0	897.0

BURBANK-WESTERN ST. DR. at Riverside Drive STATION NO. E 285-R

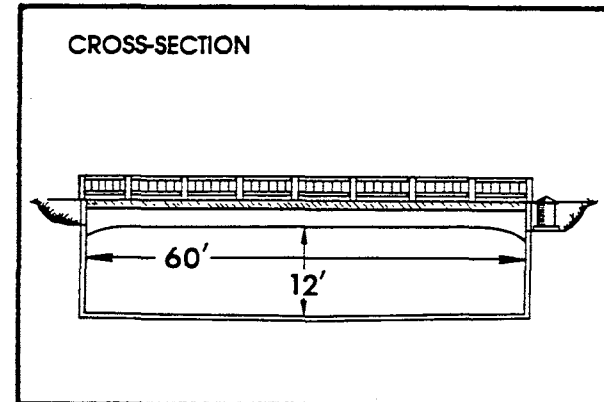
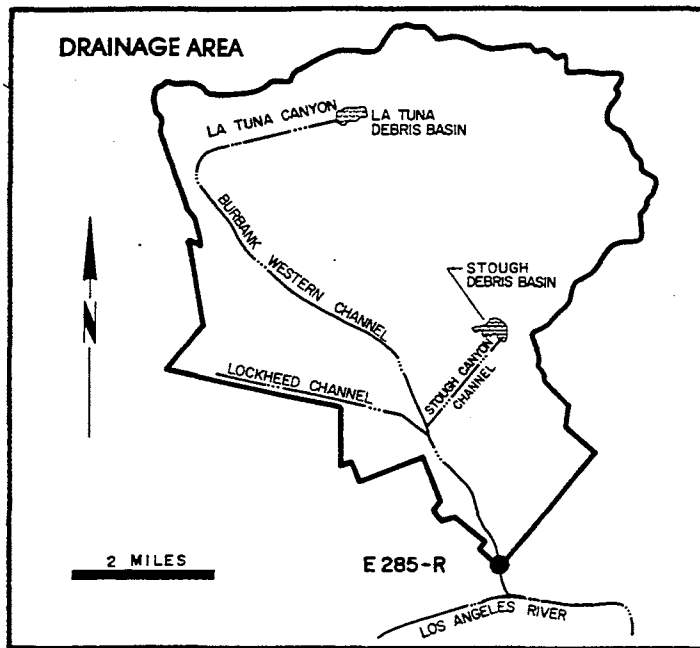
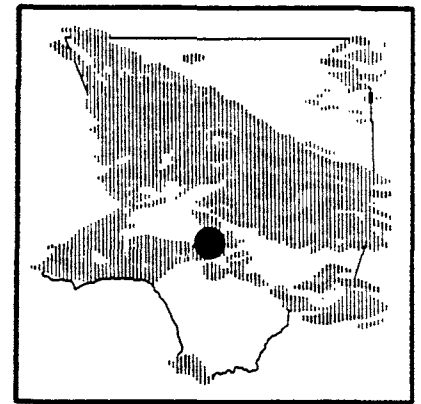

RECORDER- continuous water stage.
 METHOD OF MEASUREMENTS- wading and from bridge.
 DRAINAGE AREA- 25.0 square miles.
 LOCATION- 20.0 feet upstream from Riverside Drive bridge, Glendale.
 REGULATION- Several debris basins on tributaries.
 CHANNEL- concrete, rectangular section.
 CONTROL- channel forms control.
 LENGTH OF RECORD- October 1, 1949 to date.
 REMARKS- operated in cooperation with the USCE.

WATER YEAR 1992-1993 (DISCHARGE IN CFS)

STATION NO. : E285-R

DRAINAGE AREA : 25.00 SQ. MI.

MONTH	OCT	NOV	DEC	JAN	FEB	MAR	APR	MAY	JUN	JUL	AUG	SEP
MEAN	17.4	8.9	60.6	94.4	114.0	49.2	13.0	9.0	15.3	11.6	9.6	8.7
MAX.	150.0	14.1	523.0	403.0	564.0	437.0	15.8	12.3	146.0	13.5	11.7	10.5
MIN.	8.8	6.7	12.9	14.2	13.0	12.1	10.4	6.0	8.9	9.1	8.6	6.7
TOTAL AF	1,068.0	532.0	3,725.0	5,802.0	6,357.0	3,028.0	772.0	555.0	909.0	711.0	588.0	520.0

LOS ANGELES RIVER at Tujunga Avenue STATION NO. F300-R

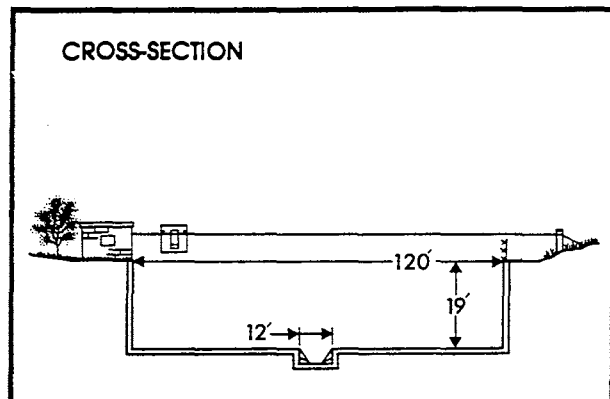
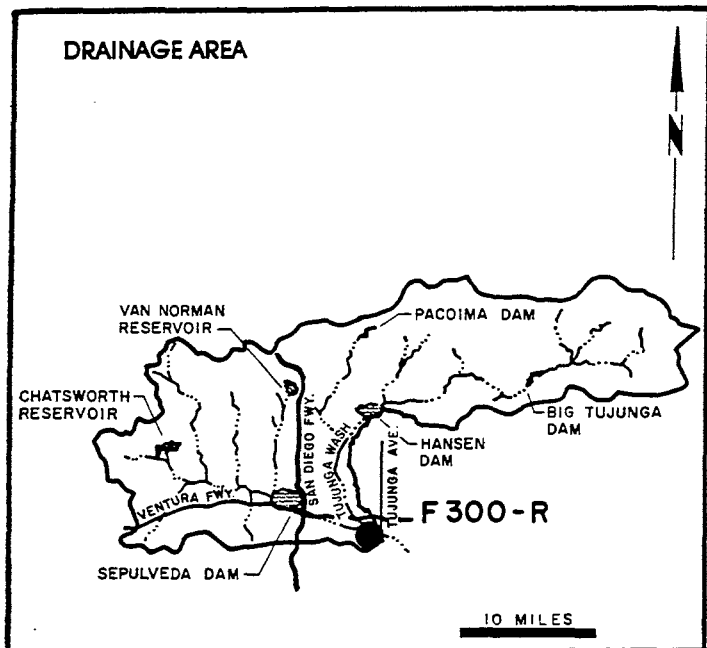
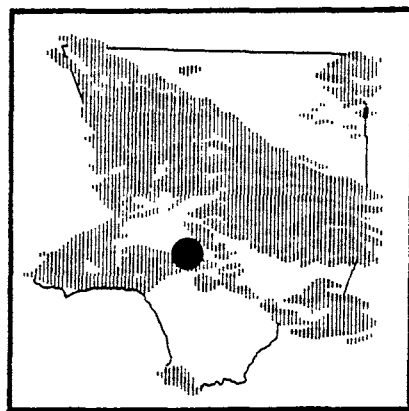

RECORDER- continuous water stage.

METHOD OF MEASUREMENTS- wading or from cable car.

DRAINAGE AREA- 401.0 square miles.

LOCATION- 200.0 feet above Tujunga Avenue bridge, Studio City.

REGULATION- flow regulated by Sepulveda, Big Tujunga, Hansen, and Pacoima Dams, Lopez Debris Dam, and Project No. 85 Diversion.

CHANNEL- concrete, rectangular section, 120 feet wide by 19 feet deep.

CONTROL- channel forms control.

LENGTH OF RECORD- May 8, 1950, to date.

REMARKS- subject to diversions at mouth of Big Tujunga and Pacoima Canyons for irrigation, at Big Tujunga, Branford, Hansen, and Pacoima Spreading Grounds.

WATER YEAR 1992-1993 (DISCHARGE IN CFS)

STATION NO. : F300-R

DRAINAGE AREA : 401.00 SQ. MI.

MONTH	OCT	NOV	DEC	JAN	FEB	MAR	APR	MAY	JUN	JUL	AUG	SEP
MEAN	87.6	62.5	362.0	1,517.0	2,076.0	520.0	132.0	75.9	96.9	63.5	58.4	60.2
MAX.	502.0	119.0	5,730.0	7,190.0	10,600.0	2,840.0	221.0	91.8	615.0	67.6	61.1	70.6
MIN.	58.3	51.9	63.8	96.2	134.0	168.0	92.6	65.2	61.1	59.2	54.8	55.0
TOTAL AF	5,389.0	3,722.0	22,250.0	93,270.0	115,300.0	31,970.0	7,861.0	4,664.0	5,768.0	3,904.0	3,593.0	3,580.0

WALNUT CREEK above Puente Avenue STATION NO. F304-R

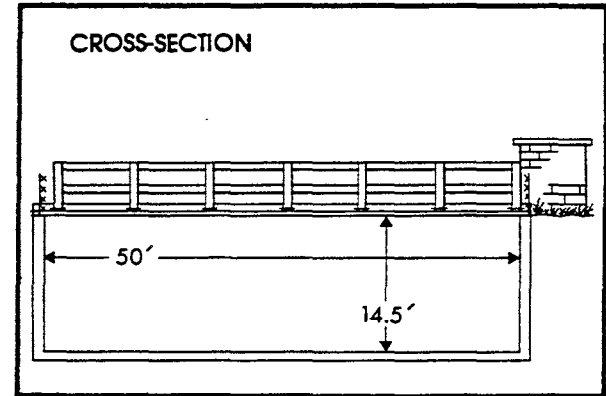
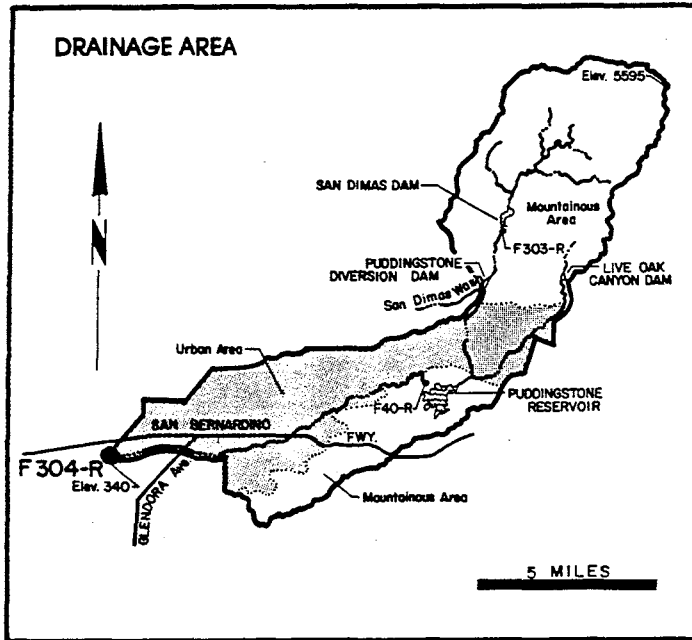
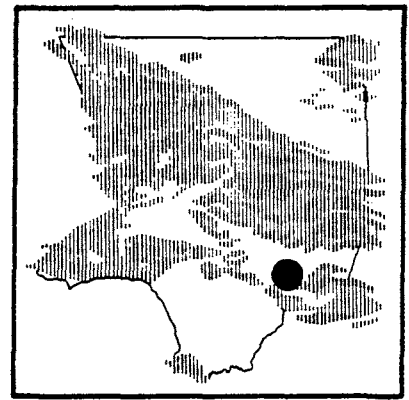

RECORDER- continuous water stage.
METHOD OF MEASUREMENTS- wading or from footbridge.
DRAINAGE AREA- 57.6 square miles.
LOCATION- 845.0 feet upstream of Puente Avenue bridge, Baldwin Park.
REGULATION- partially regulated by San Dimas, Puddingstone Diversion, Puddingstone, and Live Oak Dams.
CHANNEL- concrete, rectangular in section.
CONTROL- channel forms control.
LENGTH OF RECORD- October 14, 1952 to April 11, 1961, January 3, 1962 to date.
REMARKS- no record during April 11, 1961 to January 3, 1962 due to channel construction.

WATER YEAR 1992-1993 (DISCHARGE IN CFS)

STATION NO. : F304-R

DRAINAGE AREA : 57.60 SQ. MI.

MONTH	OCT	NOV	DEC	JAN	FEB	MAR	APR	MAY	JUN	JUL	AUG	SEP
MEAN	5.2	0.1	38.1	394.0	338.0	49.0	11.3	1.3	5.5	0.7	0.8	0.6
MAX.	113.0	0.5	295.0	1,470.0	1,090.0	205.0	32.4	4.6	135.0	2.1	2.7	1.5
MIN.	0.0	0.0	0.0	11.6	20.1	6.2	0.6	0.2	0.0	0.0	0.2	0.2
TOTAL AF	320.0	4.0	2,340.0	24,210.0	18,750.0	3,015.0	672.0	79.0	330.0	43.0	50.0	36.0

SAN JOSE CHANNEL above Workman Mill Road STATION NO. F312-R

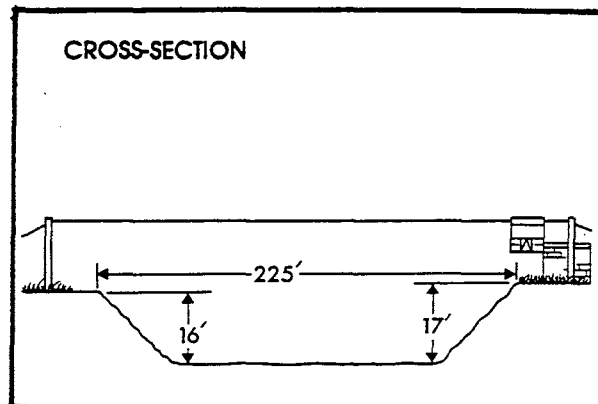
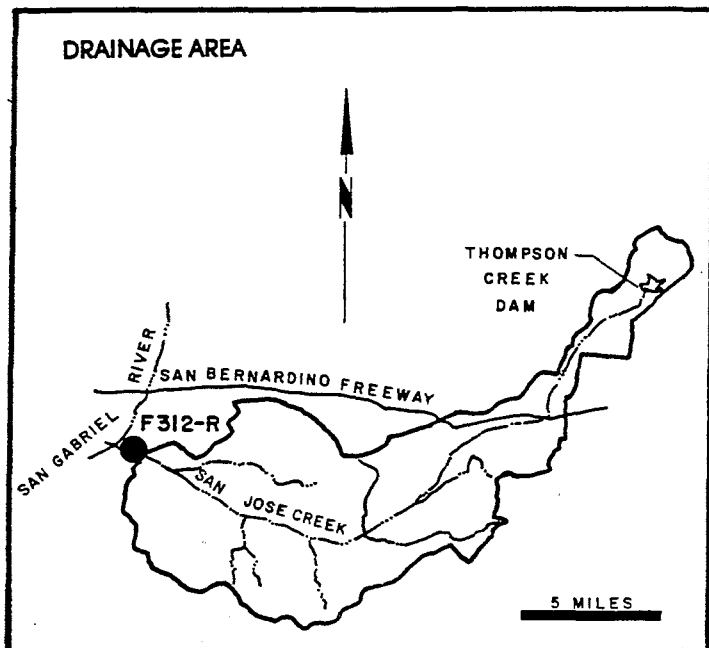
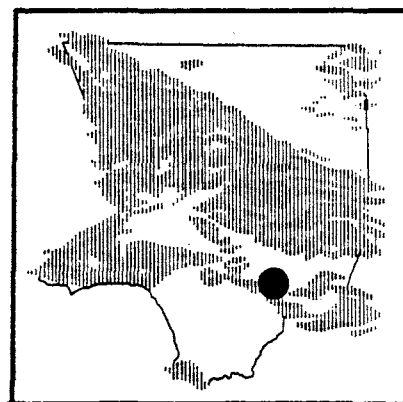

RECORDER- continuous water stage.

METHOD OF MEASUREMENTS- wading or from cable car.

DRAINAGE AREA- 83.4 square miles.

LOCATION- 1,650 feet above Workman Mill Road, 3.0 miles southeast of El Monte.

REGULATION- partially regulated by Thompson Creek Dam and Pomona Sewage Treatment Plant.

CHANNEL- grouted rip-rap side slopes with natural bottom, trapezoidal section.

CONTROL- rock stabilizer.

LENGTH OF RECORD- September 13, 1955 to date.

WATER YEAR 1992-1993 (DISCHARGE IN CFS)

STATION NO. : F312-R

DRAINAGE AREA : 83.40 SQ. MI.

MONTH	OCT	NOV	DEC	JAN	FEB	MAR	APR	MAY	JUN	JUL	AUG	SEP
MEAN	54.8	65.7	221.0	606.0	358.0	70.1	30.8	21.6	38.3		21.4	21.2
MAX.	841.0	157.0	3,430.0	4,370.0	2,670.0	583.0	39.3	28.0	606.0	NO	24.8	28.0
MIN.	7.0	17.1	15.2	16.5	20.9	29.2	24.2	17.1	11.2	RECORDS	17.1	17.7
TOTAL AF	3,371.0	3,911.0	13,610.0	37,250.0	19,910.0	4,308.0	1,834.0	1,328.0	2,281.0		1,316.0	1,264.0

ARCADIA WASH below Grand Avenue STATION NO. F 317-R

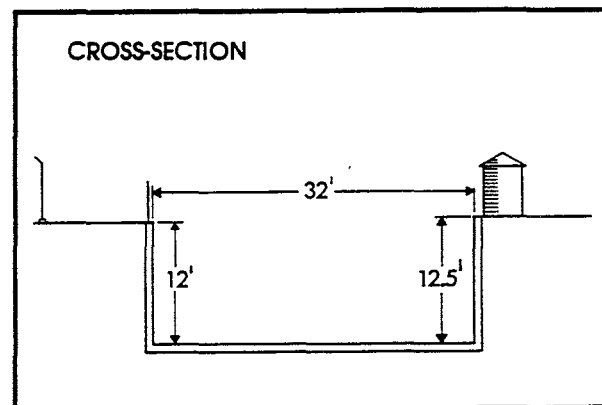
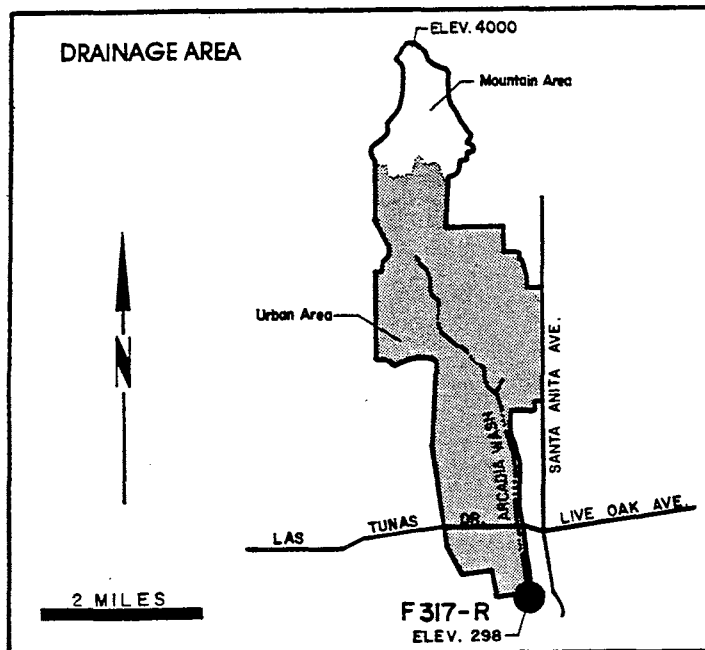
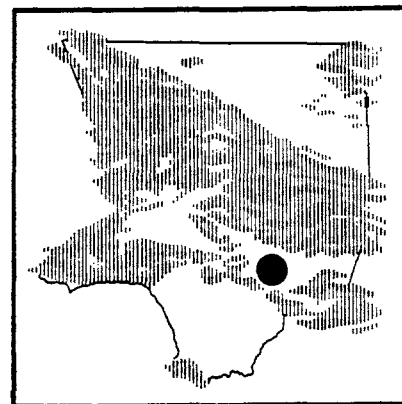

RECORDER- 15 minute punched tape.

METHOD OF MEASUREMENTS- low flows measured by wading. High flows measured from upstream side of Grand Avenue bridge.

DRAINAGE AREA- 8.5 square miles.

LOCATION- on the west wall of Arcadia Wash about 75 feet downstream from centerline of Grand Avenue.

REGULATION- several debris basins located upstream.

CHANNEL- rectangular concrete.

LENGTH OF RECORD- December 12, 1955 to date.

WATER YEAR 1992-1993 (DISCHARGE IN CFS)

STATION NO. : F317-R

DRAINAGE AREA : 8.50 SQ. MI.

MONTH	OCT	NOV	DEC	JAN	FEB	MAR	APR	MAY	JUN	JUL	AUG	SEP
MEAN	12.4	0.5	34.5	57.1	76.0	14.8	8.1	0.7	5.5	1.1	0.7	0.7
MAX.	160.0	0.8	586.0	309.0	349.0	112.0	12.2	1.0	126.0	7.5	1.2	1.0
MIN.	4.6	0.3	0.3	0.4	0.9	2.0	0.9	0.4	0.6	0.5	0.5	0.5
TOTAL AF	760.0	31.0	2,123.0	3,511.0	4,219.0	907.0	483.0	45.0	327.0	69.0	43.0	43.0

EATON WASH at Loftus Drive STATION NO. F318-R

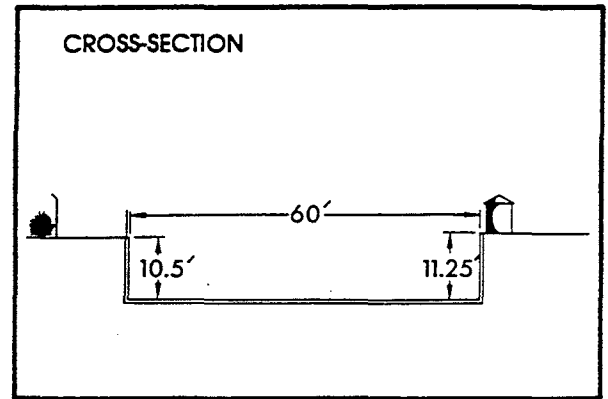
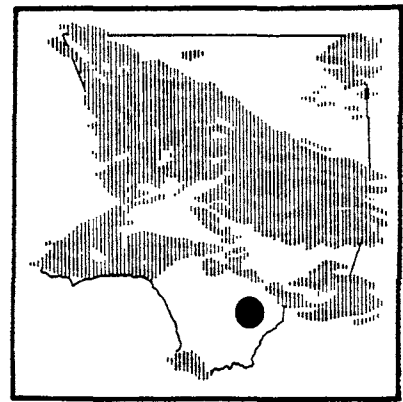
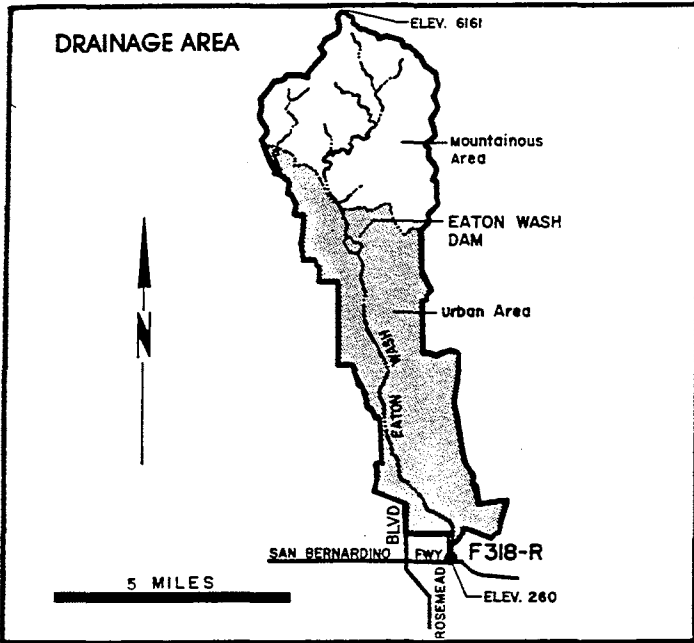

RECORDER- 15 minute punched tape.

METHOD OF MEASUREMENTS- low flows measured by wading. High flows measured from upstream side of East Loftus Drive bridge.

DRAINAGE- 22.8 square miles.

LOCATION- on the west wall of the channel 52 feet above the centerline of East Loftus Drive bridge, 1.3 miles west of El Monte.

REGULATION- partly regulated by Eaton Dam.

DIVERSIONS- the Pasadena Water Department diverts some water just above the mouth of Eaton Canyon. The Flood Control District diverts water to spreading grounds below Eaton Dam and below Huntington Drive.

CHANNEL- rectangular concrete, 60 feet wide, 11.3 feet.

CONTROL- channel forms control.

LENGTH OF RECORD- 1956 to date.

WATER YEAR 1992-1993 (DISCHARGE IN CFS)

STATION NO. : F318-R

DRAINAGE AREA : 22.80 SQ. MI.

MONTH	OCT	NOV	DEC	JAN	FEB	MAR	APR	MAY	JUN	JUL	AUG	SEP
MEAN	5.8	0.1	41.4	134.0	128.0	38.1	0.0	5.1	9.4	1.0	0.3	0.3
MAX.	158.0	0.2	664.0	622.0	467.0	142.0	0.3	12.5	127.0	3.0	0.9	1.1
MIN.	0.0	0.0	0.0	0.5	12.0	0.0	0.0	0.0	1.2	0.1	0.1	0.1
TOTAL AF	357.0	4.0	2,545.0	8,245.0	7,107.0	2,344.0	2.0	316.0	561.0	61.0	18.0	20.0

LOS ANGELES RIVER below Wardlow Road STATION NO. F319-R

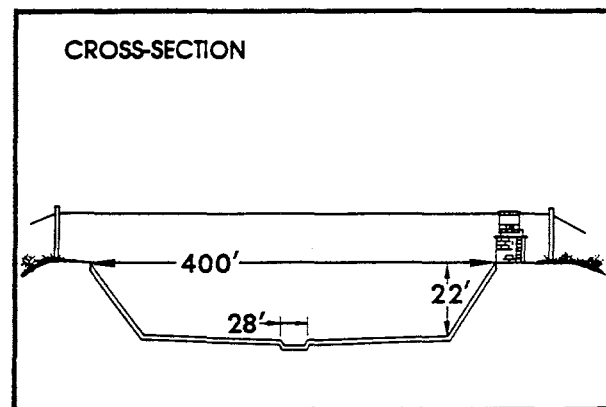
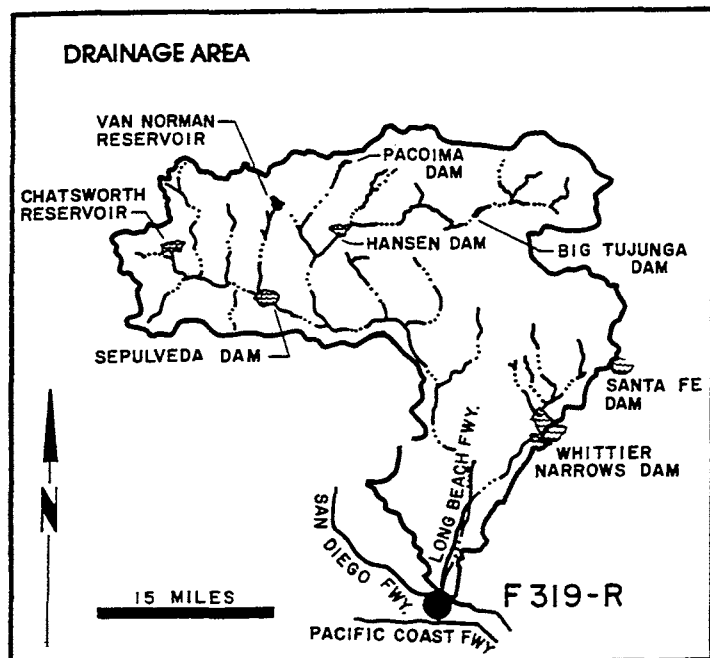
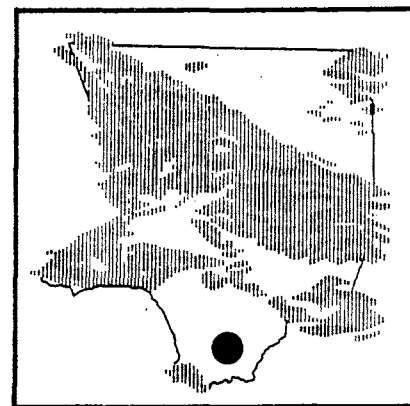

RECORDER- continuous water stage.

METHOD OF MEASUREMENTS- wading or from cable car.

DRAINAGE AREA- 815.0 square miles (excludes area above Santa Fe Dam).

LOCATION- 900.0 feet below Wardlow Road, Long Beach.

REGULATION- flow is subject to the same regulation as Stations F34D-R and P45B-R.

DIVERSIONS- flows diverted to Dominguez Gap Spreading Grounds.

CHANNEL- trapezoidal, concrete, 302.0 feet wide at bottom with 2.25:1 side slopes. Low flow channel 28.0 feet wide by 1.0 foot deep in center of channel.

CONTROL- channel forms control.

LENGTH OF RECORD- at Station F180-R October 31, 1931 to January 13, 1956. at Station F319-R January 13, 1956 to date.

REMARKS- prior to 1931, see Station F36-R.

WATER YEAR 1992-1993 (DISCHARGE IN CFS)

STATION NO. : F319-R

DRAINAGE AREA : 815.00 SQ. MI.

MONTH	OCT	NOV	DEC	JAN	FEB	MAR	APR	MAY	JUN	JUL	AUG	SEP
MEAN	313.0	229.0	1,487.0	7,022.0	6,870.0	1,676.0	234.0	176.0	447.0	165.0	165.0	159.0
MAX.	3,550.0	257.0	27,200.0	35,000.0	24,500.0	12,800.0	281.0	216.0	7,270.0	180.0	175.0	188.0
MIN.	140.0	204.0	226.0	374.0	412.0	341.0	203.0	160.0	167.0	123.0	153.0	146.0
TOTAL AF	19,240.0	13,640.0	91,430.0	431,800.0	381,500.0	103,000.0	13,920.0	10,810.0	26,590.0	10,120.0	10,140.0	9,481.0

MINT CANYON CREEK

at Finch Avenue

STATION NO. F328-R

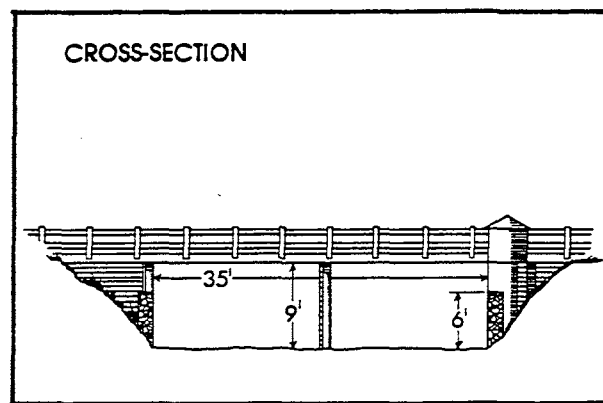
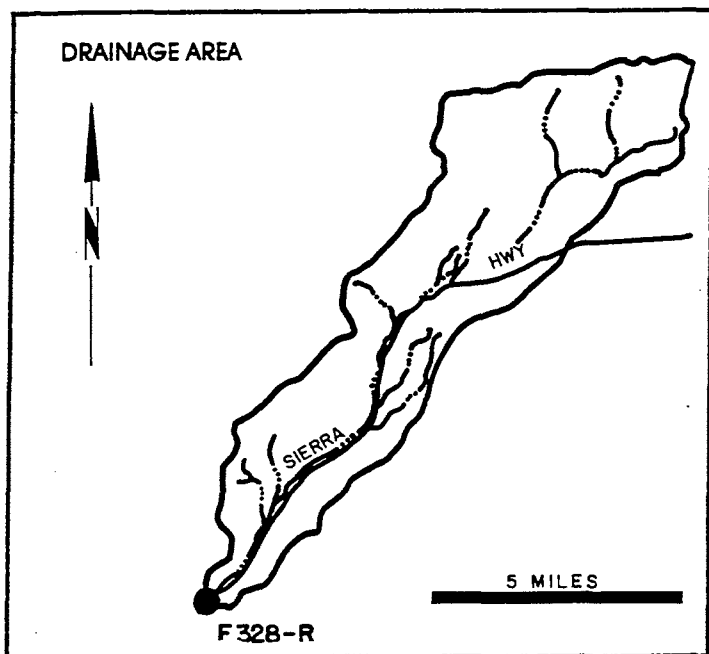
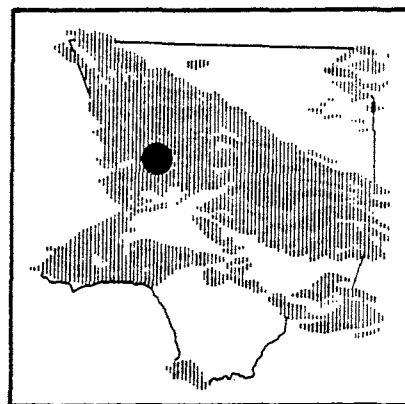

RECORDER- continuous water stage.
 METHOD OF MEASUREMENTS- wading or from bridge.
 DRAINAGE AREA- 26.9 square miles.
 LOCATION- 8.5 miles northeast of Saugus on west end of Finch Avenue bridge.
 REGULATION- none.
 CHANNEL- natural, sand and gravel.
 CONTROL- concrete control at downstream end of bridge.
 LENGTH OF RECORD- October 26, 1956 to date.

WATER YEAR 1992-1993 (DISCHARGE IN CFS)

STATION NO. : F328-R

DRAINAGE AREA : 26.90 SQ. MI.

MONTH	OCT	NOV	DEC	JAN	FEB	MAR	APR	MAY	JUN	JUL	AUG	SEP
MEAN	0.0	0.0	0.0	13.4	3.1	26.7	0.1	1.9	1.2	0.6	0.6	0.4
MAX.	0.0	0.0	0.0	26.0	16.4	77.1	1.3	2.2	5.3	1.2	1.2	0.6
MIN.	0.0	0.0	0.0	1.6	0.0	2.0	0.0	1.6	0.2	0.0	0.0	0.3
TOTAL AF	0.0	0.0	0.0	825.0	171.0	1,640.0	8.0	117.0	72.0	35.0	37.0	24.0

BRADBURY CHANNEL

below Central Avenue

STATION NO. F329-R

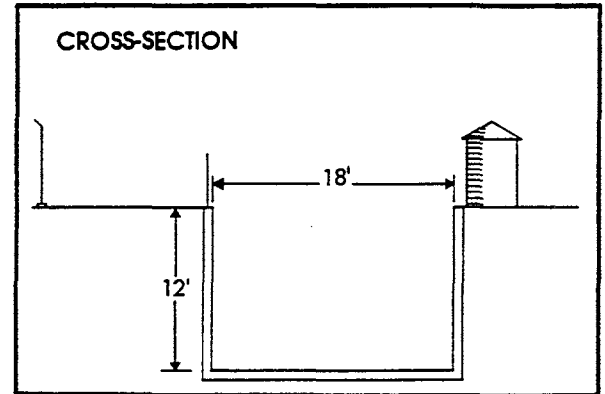
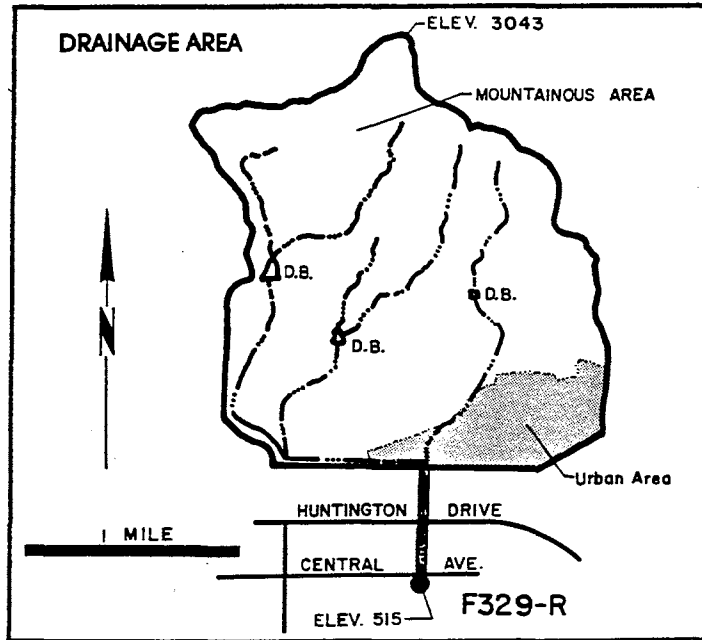
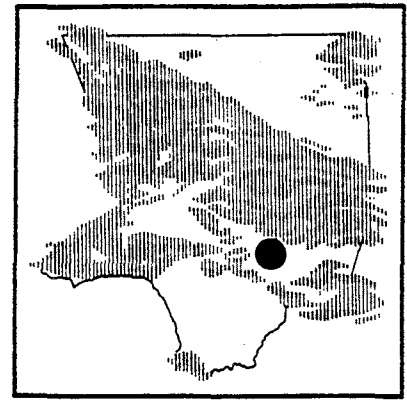

RECORDER- 15 minute punched tape.

METHOD OF MEASUREMENT- low flows measured by wading. High flows measured from footbridge four feet downstream from recorder.

DRAINAGE AREA- 3.3 square miles.

LOCATION- on the east wall of Bradbury Channel, 200 feet downstream from the centerline of Central Avenue, one mile east of Duarte.

REGULATION- two debris basins located upstream.

CHANNEL- rectangular concrete, 18 feet wide, 12 feet deep.

CONTROL- channel forms control.

LENGTH OF RECORD- June 14, 1957 to present.

WATER YEAR 1992-1993

(DISCHARGE IN CFS)

STATION NO.: F329-R

DRAINAGE AREA: 3.30 SQ. MI.

MONTH	OCT	NOV	DEC	JAN	FEB	MAR	APR	MAY	JUN	JUL	AUG	SEP
MEAN	0.6	0.0	3.1	15.6	6.9	1.8	1.0	6.8	1.0	1.1	0.1	0.2
MAX	11.6	0.1	44.9	83.6	58.3	8.7	3.1	16.7	10.3	6.6	0.6	0.4
MIN	0.0	0.0	0.0	0.3	0.0	0.7	0.5	0.9	0.6	0.2	0.1	0.1
TOTAL AF	35.0	0.0	190.0	959.0	385.0	113.0	60.0	416.0	62.0	70.0	8.0	12.0

RUBIO DIVERSION CHANNEL

below Goosebury Inlet

STATION NO. F338-R

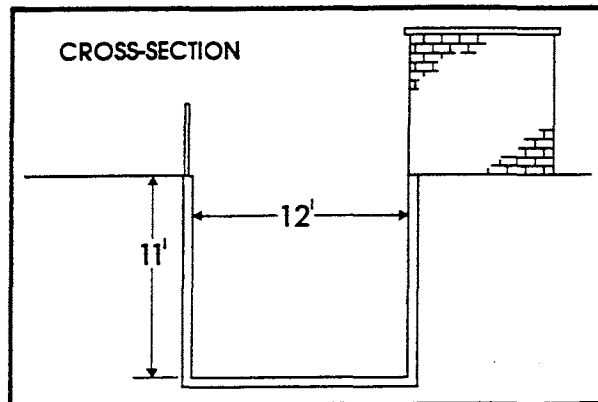
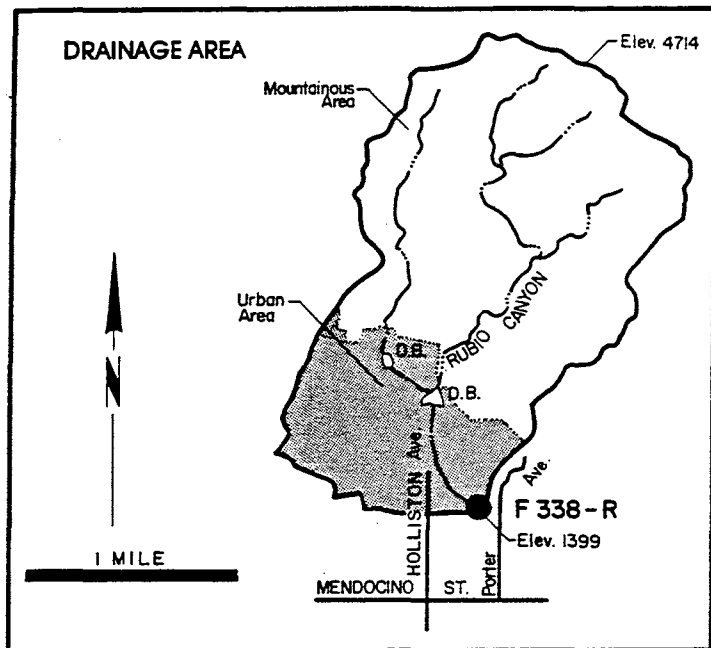
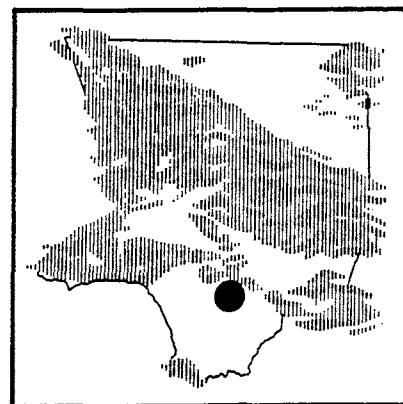

RECORDER- 15 minute punched tape.
METHOD OF MEASUREMENTS- low flows measured by wading. High flows measured from steel footbridge 27 feet above station.
DRAINAGE AREA- 2.1 square miles.
LOCATION- on the north bank, 375 feet upstream of Crest Drive, three and one-half miles northeast of Pasadena.
REGULATION- flow partially regulated by Rubio and Gooseberry Debris Basins.
DIVERSIONS- Rubio Canyon Land and Water Association diverts low flows in Rubio Canyon.
CHANNEL- rectangular concrete, 12 feet wide and 11 feet deep.
CONTROL- channel forms control.
LENGTH OF RECORD- December 16, 1959 to date.

WATER YEAR 1992-1993 (DISCHARGE IN CFS)

STATION NO. : F338-R

DRAINAGE AREA : 2.10 SQ. MI.

MONTH	OCT	NOV	DEC	JAN	FEB	MAR	APR	MAY	JUN	JUL	AUG	SEP
MEAN	0.6	0.2	1.0		4.6	8.8	7.0	3.5	2.6			
MAX.	4.1	0.8	8.7	NO	19.4	24.8	9.3	7.7	11.5	NO RECORDS		
MIN.	0.0	0.0	0.0	RECORDS	1.8	2.0	6.2	1.8	1.2			
TOTAL AF	35.0	12.0	60.0		255.0	544.0	418.0	216.0	154.0			

BRANFORD STREET CHANNEL

below Sharp Avenue
STATION NO. F342-R

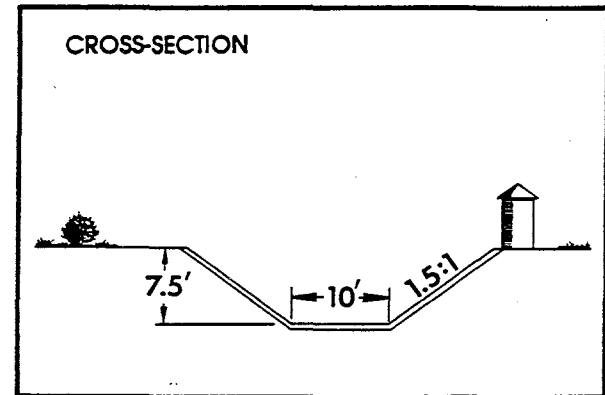
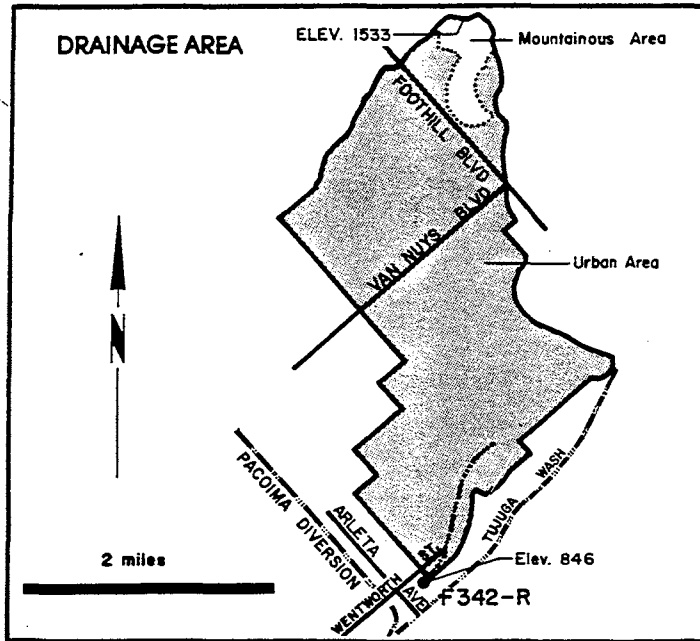
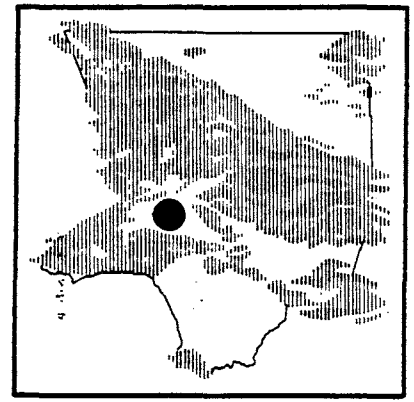

RECORDER- 15 minute punched tape.

METHOD OF MEASUREMENTS- low flows measured by wading. High flows measured by floats.

DRAINAGE AREA- 5.01 square miles.

LOCATION- on the south bank of channel, 125 feet downstream from Sharp Avenue, about 3.6 miles south of San Fernando.

REGULATION- flow from Lopez Creek is diverted to Hansen Dam at the mouth of Lopez Canyon.

CHANNEL- trapezoidal, 10 feet wide at bottom and 7.5 feet deep with 1.5 to 1 side slopes.

CONTROL- channel forms control.

LENGTH OF RECORD- January 12, 1962 to date.

WATER YEAR 1992-1993 (DISCHARGE IN CFS)

STATION NO. : F342-R

DRAINAGE AREA : 5.01 SQ. MI.

MONTH	OCT	NOV	DEC	JAN	FEB	MAR	APR	MAY	JUN	JUL	AUG	SEP
MEAN	1.5	0.0	5.4	14.5				0.0	0.8	0.0	0.0	0.0
MAX.	30.3	0.1	107.0	86.8	NO RECORDS			0.0	24.2	0.0	0.1	0.0
MIN.	0.0	0.0	0.0	0.0				0.0	0.0	0.0	0.0	0.0
TOTAL AF	95.0	0.0	329.0	895.0				0.0	48.0	0.0	0.0	0.0

COYOTE CREEK

below Spring Street

STATION NO. F354-R

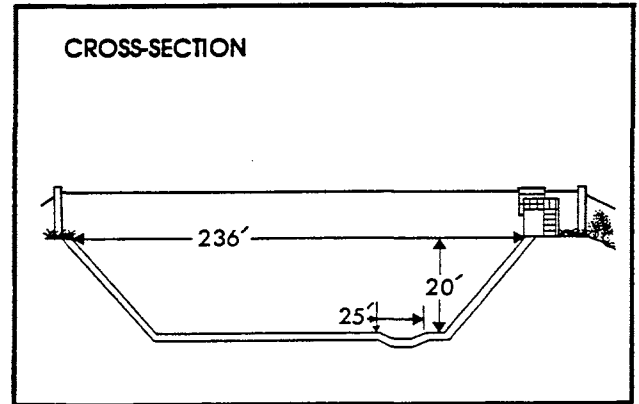
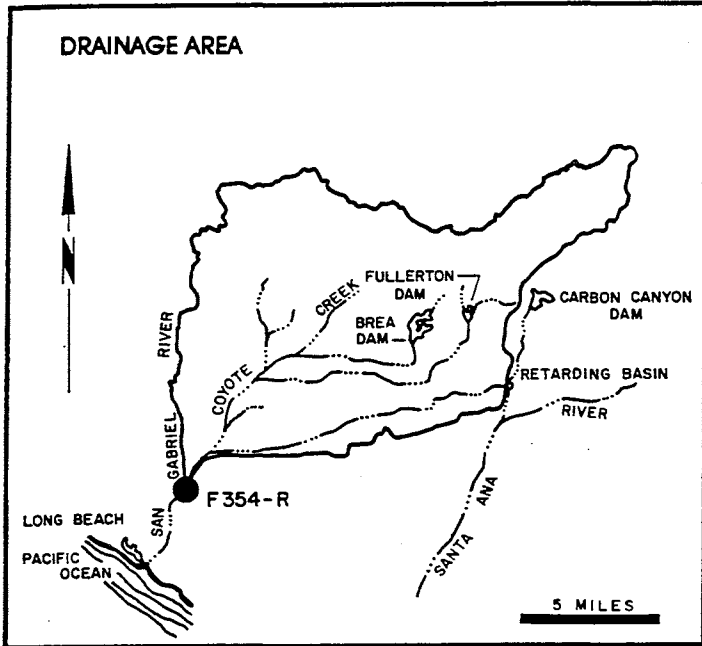
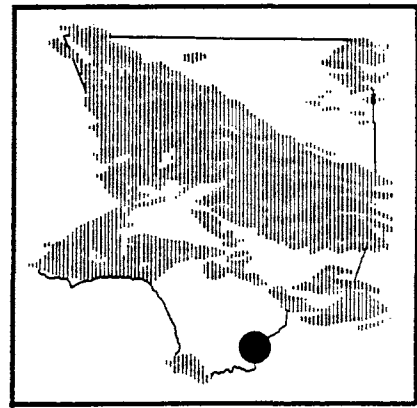

RECORDER- continuous water stage.

METHOD OF MEASUREMENTS- wading or from cable car.

DRAINAGE AREA- 185.0 square miles.

LOCATION- 241.0 feet below Spring Street, 7.5 miles northeast of Long Beach.

REGULATION- partially regulated by Fullerton Dam, Brea Dam, and Carbon Canyon Dam.

CHANNEL- concrete, trapezoidal in section.

CONTROL- channel forms control.

LENGTH OF RECORD - December 17, 1963 to date.

REMARKS - previous gaging stations for record correlation: Station F41 - S December 1, 1928 to January 14, 1930. Station F41 - R January 14, 1930 to October 30, 1936. Station F41B - R October 30, 1936 to February 17, 1937. Station F41C - R February 18, 1937 to February 8, 1956. Station F320 - R February 9, 1956 to July 2, 1965.

WATER YEAR 1992-1993

(DISCHARGE IN CFS)

STATION NO. : F354-R

DRAINAGE AREA : 185.00 SQ. MI.

MONTH	OCT	NOV	DEC	JAN	FEB	MAR	APR	MAY	JUN	JUL	AUG	SEP
MEAN	65.5	13.6	251.0	608.0	656.0	102.0	13.5	9.6	44.5	13.5	10.3	9.3
MAX.	1,410.0	127.0	5,030.0	3,590.0	3,150.0	1,220.0	19.1	17.6	981.0	18.2	14.3	13.7
MIN.	3.8	3.9	14.2	18.6	21.7	19.1	8.8	4.8	7.7	10.2	8.5	6.3
TOTAL AF	4,029.0	811.0	15,410.0	37,400.0	36,460.0	6,269.0	805.0	590.0	2,648.0	832.0	631.0	550.0

BOUQUET CANYON CREEK

at Urbandale Avenue

STATION NO. F377-R

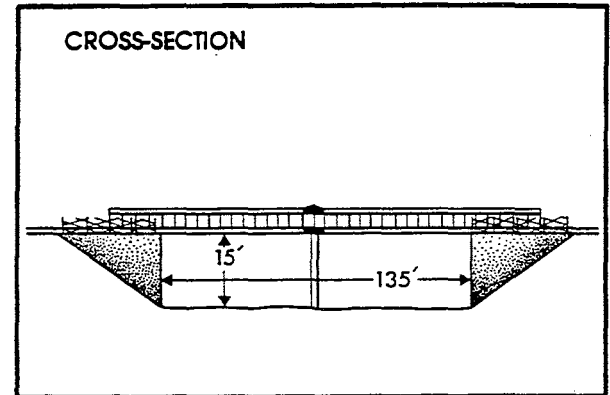
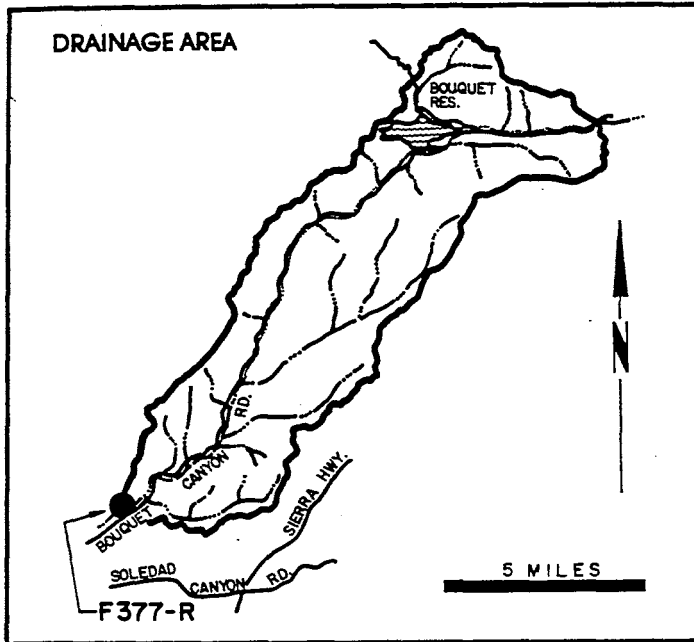
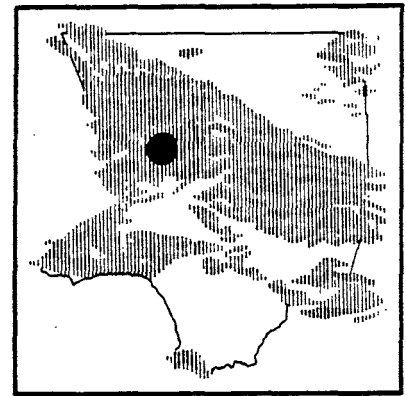

RECORDER- continuous water stage.
 METHOD OF MEASUREMENTS- wading or from bridge.
 DRAINAGE AREA- 51.9 square miles.
 LOCATION- Bouquet Canyon Creek at Urbandale Avenue, 3.5 miles northeast of Saugus.
 REGULATION- Bouquet Reservoir.
 CHANNEL- concrete sides with natural bottom, trapezoidal in section.
 CONTROL- concrete stabilizer.
 LENGTH OF RECORD- October 11, 1967 to date.

WATER YEAR 1992-1993 (DISCHARGE IN CFS)

STATION NO. : F377-R

DRAINAGE AREA : 51.90 SQ. MI.

MONTH	OCT	NOV	DEC	JAN	FEB	MAR	APR	MAY	JUN	JUL	AUG	SEP
MEAN	0.0							1.0	1.0	0.9	0.5	0.3
MAX.	0.0	RECORDER INOPERATIVE FOR THIS PERIOD						1.0	1.0	1.3	0.8	1.0
MIN.	0.0							1.0	1.0	0.8	0.2	0.0
TOTAL AF	0.0							61.0	60.0	58.0	28.0	20.0

RESERVOIRS

RESERVOIRS

Following the damaging flood of 1914 and creation of the Los Angeles County Flood Control District in 1915, a program of flood control and water conservation was initiated. Part of this program included the construction of 14 dams which were completed between 1920 and 1939. These dams were operated by the Department during the period covered by this report. In addition, five Corps of Engineers' dams, Lopez, Hansen, Santa Fe, Sepulveda and Whittier Narrows Dams, and Morris Dam owned by The Metropolitan Water District were operated in conjunction with the Department dams to achieve flood control and/or water conservation.

OPERATION

The reservoirs are operated to control flood waters during storm periods. Post storm releases are made, when feasible, in amounts which can be conserved in downstream spreading grounds and by channel percolation. Cleanouts are done to regain storage capacity in reservoirs (see Erosion Control for cleanout data).

RECORDS

The storage and flow records at the 14 Department reservoirs are summarized on the Dam Operation Record Sheets. The sheets show:

1. Daily reservoir water surface elevations. Elevations are obtained from water stage recorder graphs or interpolation from staff gage readings and recorded as of midnight of each day. Only maximum and minimum water surface elevations for each year are shown.
2. Available storage in acre-feet based on the most recent topographic surveys. Annual storage volumes are shown.
3. Stream inflow rates in cubic feet per second. This is usually calculated from storage change and known outflow.
4. Outflow in cubic feet per second. These values are determined from gaging station records, or when these are not available, from valve and spillway rating curves. Only the maximum and minimum of the daily outflow rates for the year and the instantaneous peak outflow rate are shown.
5. Discrepancies between outflow and storage losses at certain dams are attributable to evaporation and/or percolation losses. Total monthly evaporation losses are determined from the measurements made on land evaporation pans. In those cases where no allowances were made for evaporation, the amounts are necessarily included in the flow values. Accuracy of flow records computed from storage records is dependent on the frequency with which storage data are revised to keep in step with the physical change in reservoirs due to sediment deposition, accumulation and removal.

SEDIMENT REMOVAL FROM RESERVOIRS

Sediment deposition in reservoirs reduces the storage capacities and adversely affects flood control and water conservation efforts. Sediment removal is periodically necessary and is generally an expensive effort due to large quantities, the need to deal with water inflows, and in several cases, remote locations and limited accessibility for equipment.

Where practical, the Department encourages sediment removal by permittees at no cost to the Department such as at Eaton Wash and Devil's Gate Dams. During the 1992-93 water year the Department completed cleanouts in San Gabriel, San Dimas, Eaton Wash, and Santa Anita Reservoirs.

San Gabriel Reservoir cleanout consisted of an emergency sluicing operation that lasted from August through December 1992, removing approximately 2.0 million cy of sediment. Eaton Wash Reservoir cleanout removed 314,500 cy of sediment and was completed in November 1993. San Dimas and Santa Anita Reservoirs removed approximately 87,000 cy and 72,000 cy respectively. San Dimas Reservoir cleanout was completed in July 1993, and Santa Anita cleanout was completed in September 1993.

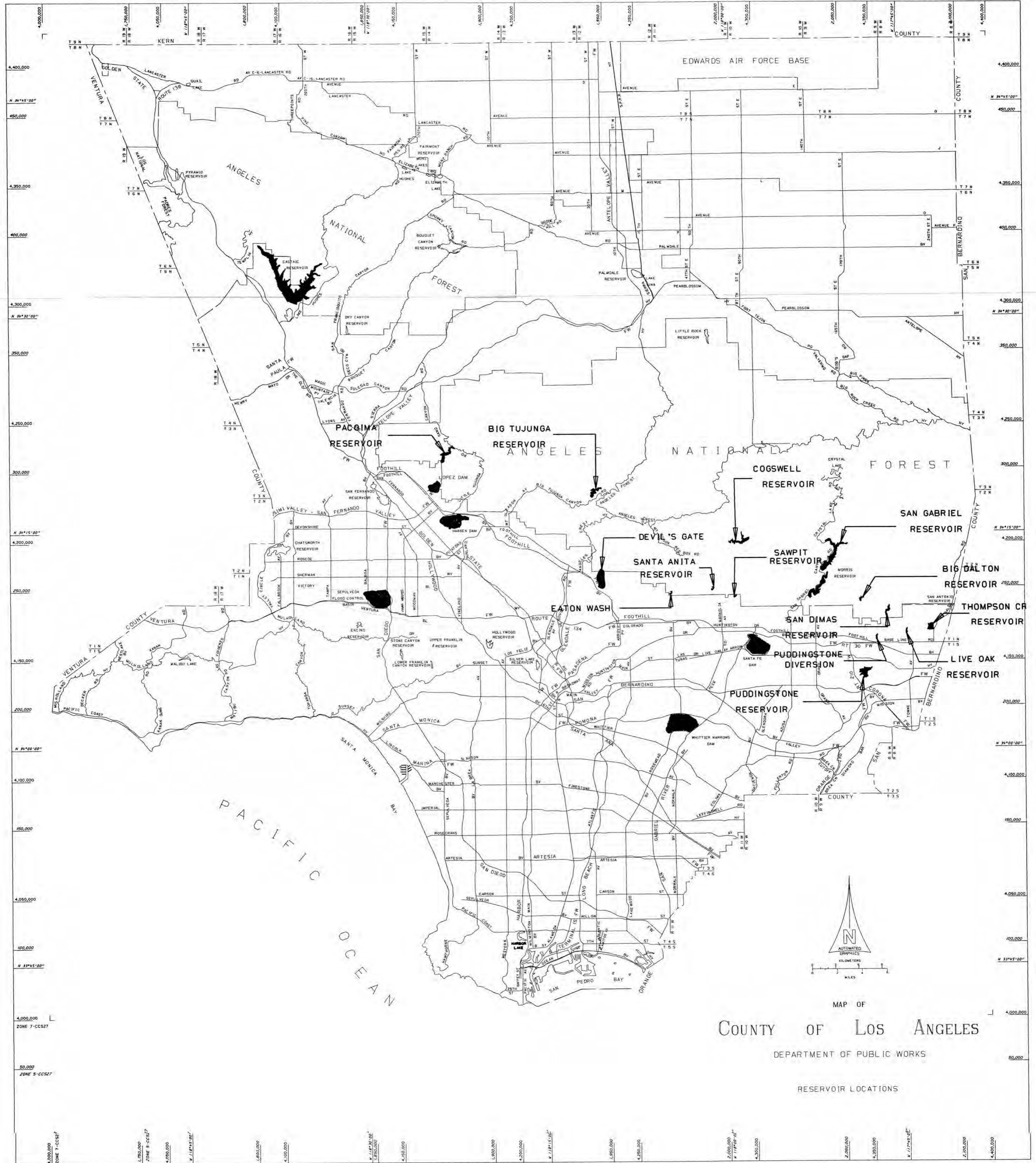

PACIFIC OCEAN

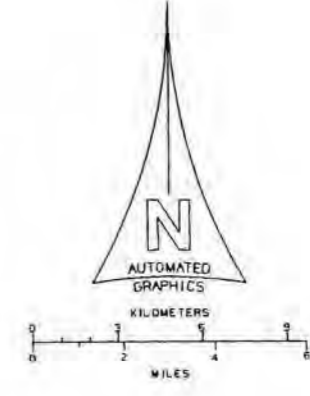

MAP OF
COUNTY OF LOS ANGELES

DEPARTMENT OF PUBLIC WORKS

RESERVOIR LOCATIONS

4,000,000
 ZONE 7-CC527
 4,950,000
 ZONE 5-CC527
 4,900,000
 ZONE 5-CC527
 4,850,000
 ZONE 5-CC527
 4,800,000
 ZONE 5-CC527
 4,750,000
 ZONE 5-CC527
 4,700,000
 ZONE 5-CC527
 4,650,000
 ZONE 5-CC527
 4,600,000
 ZONE 5-CC527
 4,550,000
 ZONE 5-CC527
 4,500,000
 ZONE 5-CC527
 4,450,000
 ZONE 5-CC527
 4,400,000
 ZONE 5-CC527
 4,350,000
 ZONE 5-CC527
 4,300,000
 ZONE 5-CC527
 4,250,000
 ZONE 5-CC527
 4,200,000
 ZONE 5-CC527
 4,150,000
 ZONE 5-CC527
 4,100,000
 ZONE 5-CC527
 4,050,000
 ZONE 5-CC527
 4,000,000
 ZONE 5-CC527
 3,950,000
 ZONE 5-CC527
 3,900,000
 ZONE 5-CC527
 3,850,000
 ZONE 5-CC527
 3,800,000
 ZONE 5-CC527
 3,750,000
 ZONE 5-CC527
 3,700,000
 ZONE 5-CC527
 3,650,000
 ZONE 5-CC527
 3,600,000
 ZONE 5-CC527
 3,550,000
 ZONE 5-CC527
 3,500,000
 ZONE 5-CC527
 3,450,000
 ZONE 5-CC527
 3,400,000
 ZONE 5-CC527
 3,350,000
 ZONE 5-CC527
 3,300,000
 ZONE 5-CC527
 3,250,000
 ZONE 5-CC527
 3,200,000
 ZONE 5-CC527
 3,150,000
 ZONE 5-CC527
 3,100,000
 ZONE 5-CC527
 3,050,000
 ZONE 5-CC527
 3,000,000
 ZONE 5-CC527
 2,950,000
 ZONE 5-CC527
 2,900,000
 ZONE 5-CC527
 2,850,000
 ZONE 5-CC527
 2,800,000
 ZONE 5-CC527
 2,750,000
 ZONE 5-CC527
 2,700,000
 ZONE 5-CC527
 2,650,000
 ZONE 5-CC527
 2,600,000
 ZONE 5-CC527
 2,550,000
 ZONE 5-CC527
 2,500,000
 ZONE 5-CC527
 2,450,000
 ZONE 5-CC527
 2,400,000
 ZONE 5-CC527
 2,350,000
 ZONE 5-CC527
 2,300,000
 ZONE 5-CC527
 2,250,000
 ZONE 5-CC527
 2,200,000
 ZONE 5-CC527
 2,150,000
 ZONE 5-CC527
 2,100,000
 ZONE 5-CC527
 2,050,000
 ZONE 5-CC527
 2,000,000
 ZONE 5-CC527
 1,950,000
 ZONE 5-CC527
 1,900,000
 ZONE 5-CC527
 1,850,000
 ZONE 5-CC527
 1,800,000
 ZONE 5-CC527
 1,750,000
 ZONE 5-CC527
 1,700,000
 ZONE 5-CC527
 1,650,000
 ZONE 5-CC527
 1,600,000
 ZONE 5-CC527
 1,550,000
 ZONE 5-CC527
 1,500,000
 ZONE 5-CC527
 1,450,000
 ZONE 5-CC527
 1,400,000
 ZONE 5-CC527
 1,350,000
 ZONE 5-CC527
 1,300,000
 ZONE 5-CC527
 1,250,000
 ZONE 5-CC527
 1,200,000
 ZONE 5-CC527
 1,150,000
 ZONE 5-CC527
 1,100,000
 ZONE 5-CC527
 1,050,000
 ZONE 5-CC527
 1,000,000
 ZONE 5-CC527
 950,000
 ZONE 5-CC527
 900,000
 ZONE 5-CC527
 850,000
 ZONE 5-CC527
 800,000
 ZONE 5-CC527
 750,000
 ZONE 5-CC527
 700,000
 ZONE 5-CC527
 650,000
 ZONE 5-CC527
 600,000
 ZONE 5-CC527
 550,000
 ZONE 5-CC527
 500,000
 ZONE 5-CC527
 450,000
 ZONE 5-CC527
 400,000
 ZONE 5-CC527
 350,000
 ZONE 5-CC527
 300,000
 ZONE 5-CC527
 250,000
 ZONE 5-CC527
 200,000
 ZONE 5-CC527
 150,000
 ZONE 5-CC527
 100,000
 ZONE 5-CC527
 50,000
 ZONE 5-CC527
 0
 ZONE 5-CC527

BIG DALTON DAM AND RESERVOIR

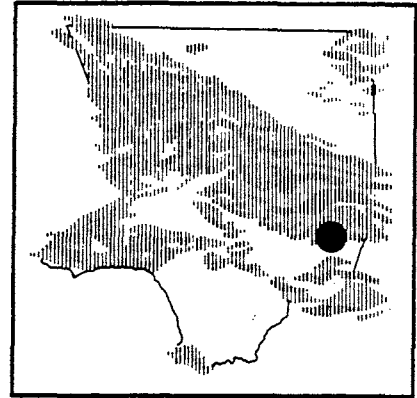
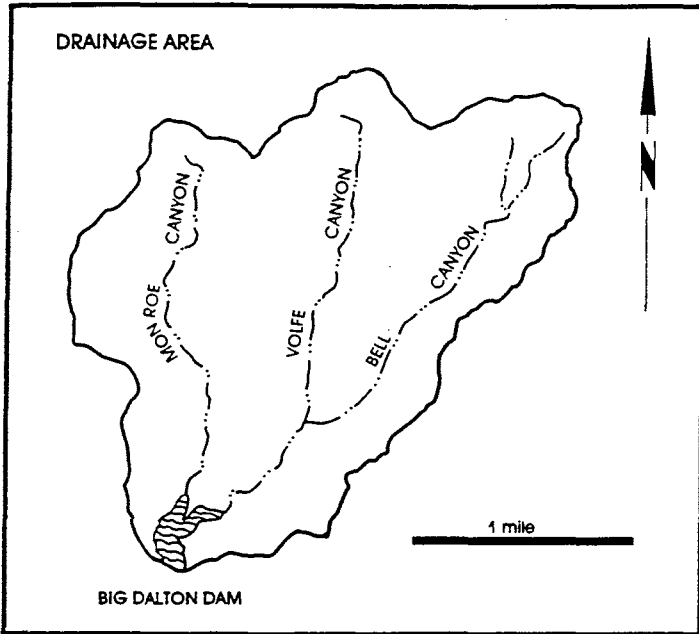

PURPOSE - Flood Control and Conservation.
 DATE CONSTRUCTED - Started December 1927. Completed August 1929.
 LOCATION - Big Dalton Canyon, 4.0 miles northeast of Glendora.
 DRAINAGE AREA - 4.5 square miles.
 CAPACITY - 963 acre - feet.
 SPILLWAY ELEVATION - 1,706.0 feet.

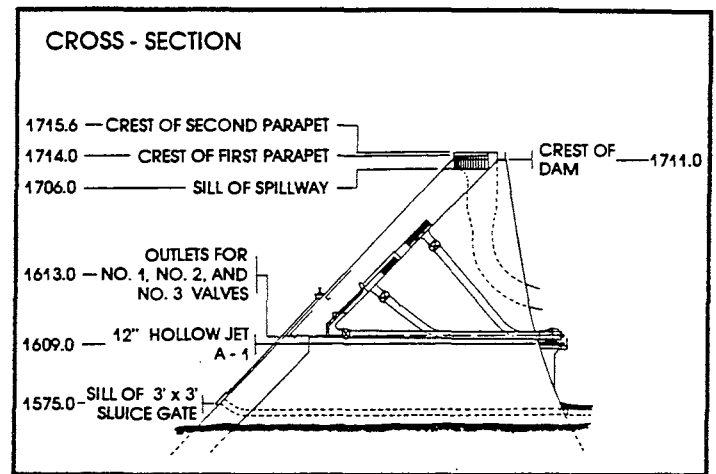

DAM OPERATION RECORD SUMMARY

MAX. PEAK INFLOW	384.54 CFS from 0300 on 01-18-93 to 0400 on 01-18-93
MAX. PEAK OUTFLOW	415.00 CFS from 1930 on 01-16-93 to 1945 on 01-16-93
MAX. W.S. ELEVATION	1683.50 feet on 01-16-93 STORAGE 479.20 ACRE-FEET
MIN. W.S. ELEVATION	1617.00 feet on Varies STORAGE 26.60 ACRE-FEET

BIG DALTON DAM OPERATION RECORD SUMMARY

WATER YEAR 1992-1993	OCTOBER	NOVEMBER	DECEMBER	JANUARY
TOTAL MONTHLY INFLOW (AF)	15.90	4.40	52.00	3,408.10
TOTAL MONTHLY OUTFLOW (AF)	29.40	0.00	42.10	3,357.80
MAX. MEAN DAILY INFLOW (CFS)	1.20	0.30	6.10	322.10
TOTAL MONTHLY LOSSES (AF)	1.00	2.50	0.40	0.60
MIN. MEAN DAILY INFLOW (CFS)	0.00	0.00	0.10	1.10
MONTHLY STORAGE CHANGE	-14.50	1.90	9.50	49.70

WATER YEAR 1992-1993	FEBRUARY	MARCH	APRIL	MAY
TOTAL MONTHLY INFLOW (AF)	2,030.40	904.90	301.10	93.20
TOTAL MONTHLY OUTFLOW (AF)	2,065.60	922.10	303.90	117.00
MAX. MEAN DAILY INFLOW (CFS)	123.90	33.00	9.30	3.10
TOTAL MONTHLY LOSSES (AF)	1.20	0.70	1.10	1.20
MIN. MEAN DAILY INFLOW (CFS)	7.80	6.70	1.20	0.90
MONTHLY STORAGE CHANGE	-36.40	-17.90	-3.90	-25.00

WATER YEAR 1992-1993	JUNE	JULY	AUGUST	SEPTEMBER
TOTAL MONTHLY INFLOW (AF)	135.30	63.20	53.30	40.10
TOTAL MONTHLY OUTFLOW (AF)	152.50	63.50	52.20	40.10
MAX. MEAN DAILY INFLOW (CFS)	4.90	1.30	1.10	0.90
TOTAL MONTHLY LOSSES (AF)	1.10	0.80	0.70	0.00
MIN. MEAN DAILY INFLOW (CFS)	0.80	0.80	0.60	0.00
MONTHLY STORAGE CHANGE	-18.30	-1.10	0.40	0.00

BIG TUJUNGA DAM AND RESERVOIR

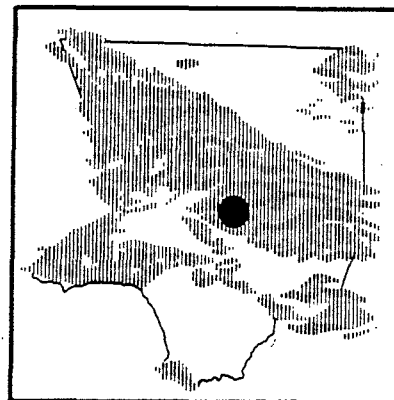
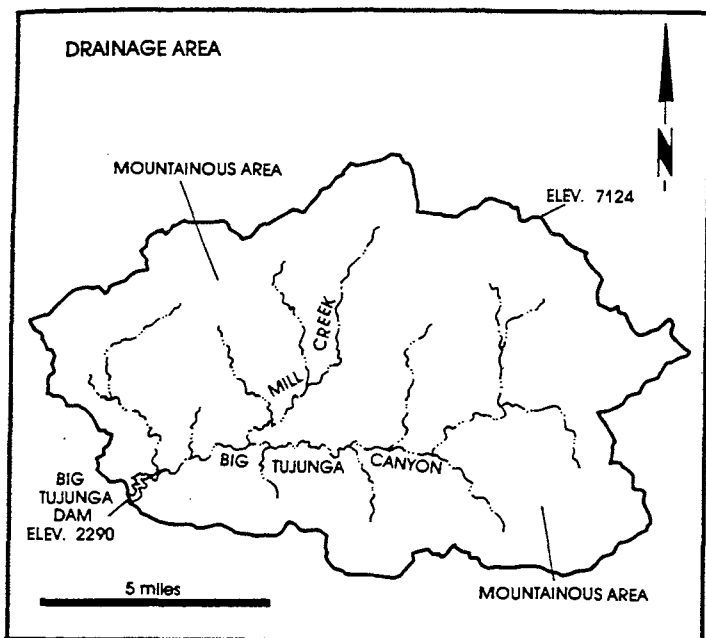

PURPOSE - Flood Control Conservation.
 DATE CONSTRUCTED - Started January 1930. Completed July 1931.
 LOCATION - Big Tujunga Canyon, 10.0 miles northeast of Sunland.
 DRAINAGE AREA - 82.3 square miles.
 CAPACITY - 6,027 acre - feet.
 SPILLWAY ELEVATION - 2,290.0 feet.

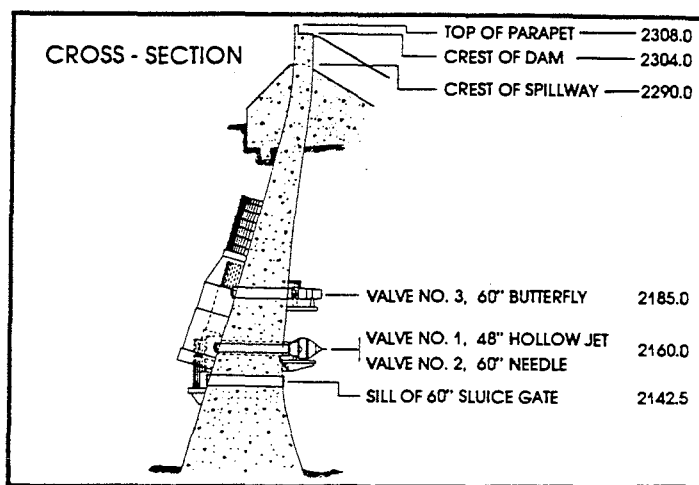

DAM OPERATION RECORD SUMMARY

MAX. PEAK INFLOW	7773.79 CFS from 0000 on 02-19-93 to 0100 on 02-19-93
MAX. PEAK OUTFLOW	3620.00 CFS from 0800 on 02-19-93 to 0815 on 02-19-93
MAX. W.S. ELEVATION	2294.30 feet on 02-19-93 STORAGE 6055.50 ACRE-FEET
MIN. W.S. ELEVATION	2198.60 feet on 12-21-92 STORAGE 892.30 ACRE-FEET

BIG TUJUNGA DAM OPERATION RECORD SUMMARY

WATER YEAR 1992-1993	OCTOBER	NOVEMBER	DECEMBER	JANUARY
TOTAL MONTHLY INFLOW (AF)	178.80	355.50	1,742.70	29,306.70
TOTAL MONTHLY OUTFLOW (AF)	269.70	269.40	1,724.40	25,717.50
MAX. MEAN DAILY INFLOW (CFS)	14.30	9.70	171.30	1,842.80
TOTAL MONTHLY LOSSES (AF)	17.50	11.40	10.60	9.60
MIN. MEAN DAILY INFLOW (CFS)	1.00	0.20	6.10	7.70
MONTHLY STORAGE CHANGE	-108.40	74.70	7.70	3,579.60

WATER YEAR 1992-1993	FEBRUARY	MARCH	APRIL	MAY
TOTAL MONTHLY INFLOW (AF)	30,934.30	13,606.40	5,058.50	2,519.60
TOTAL MONTHLY OUTFLOW (AF)	32,016.40	11,624.70	8,398.20	3,722.70
MAX. MEAN DAILY INFLOW (CFS)	3,489.50	375.40	209.50	58.40
TOTAL MONTHLY LOSSES (AF)	15.20	25.00	50.30	20.20
MIN. MEAN DAILY INFLOW (CFS)	101.90	118.40	27.60	12.80
MONTHLY STORAGE CHANGE	-1,097.30	1,956.70	-3,390.00	-1,223.30

WATER YEAR 1992-1993	JUNE	JULY	AUGUST	SEPTEMBER
TOTAL MONTHLY INFLOW (AF)	2,971.00	1,439.50	756.70	622.30
TOTAL MONTHLY OUTFLOW (AF)	3,036.70	1,340.40	719.60	471.30
MAX. MEAN DAILY INFLOW (CFS)	78.50	44.70	15.10	12.40
TOTAL MONTHLY LOSSES (AF)	19.90	19.00	23.60	21.50
MIN. MEAN DAILY INFLOW (CFS)	30.00	2.70	10.80	8.10
MONTHLY STORAGE CHANGE	-85.60	80.10	13.50	129.50

COGSWELL DAM AND RESERVOIR

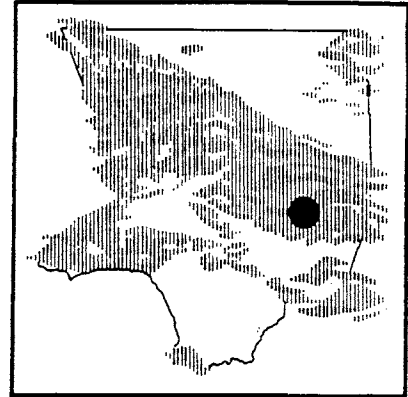
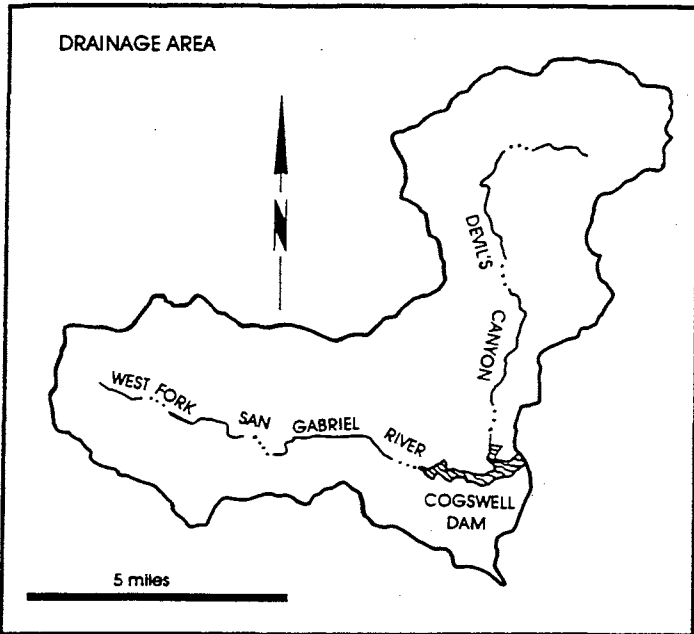

PURPOSE - Flood Control, Conservation, and Recreation.
 DATE CONSTRUCTED - Started March 1932. Completed April 1934.
 LOCATION - 22.0 miles north of Azusa.
 DRAINAGE AREA - 39.2 square miles.
 CAPACITY - 9,339 acre - feet.
 SPILLWAY ELEVATION - 2,385.0 feet.

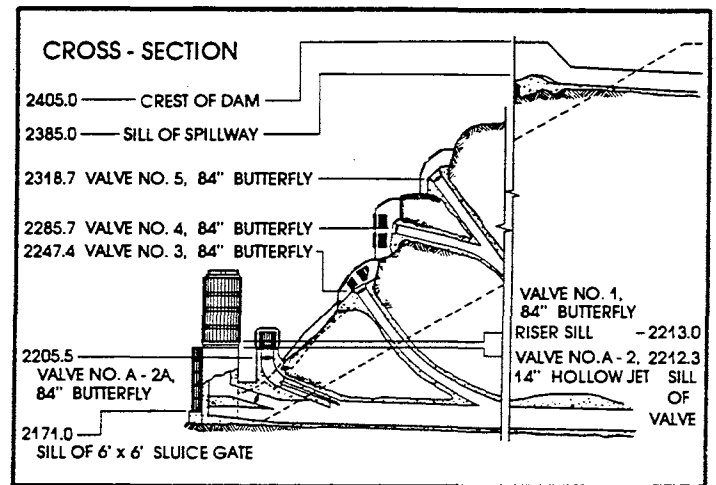

DAM OPERATION RECORD SUMMARY

MAX. PEAK INFLOW	4135.19 CFS from 0000 on 02-19-93 to 0100 on 02-19-93
MAX. PEAK OUTFLOW	1550.00 CFS from 1545 on 01-14-93 to 1600 on 01-14-93
MAX. W.S. ELEVATION	2386.00 feet on 03-22-93 STORAGE 9114.10 ACRE- FEET
MIN. W.S. ELEVATION	2221.30 feet on 12-17-92 STORAGE 54.70 ACRE- FEET

COGSWELL DAM OPERATION RECORD SUMMARY

WATER YEAR 1992-1993	OCTOBER	NOVEMBER	DECEMBER	JANUARY
TOTAL MONTHLY INFLOW (AF)	146.00	93.40	1,849.20	30,579.40
TOTAL MONTHLY OUTFLOW (AF)	121.80	116.60	1,803.20	26,343.10
MAX. MEAN DAILY INFLOW (CFS)	16.10	3.60	243.20	2,028.90
TOTAL MONTHLY LOSSES (AF)	4.20	2.50	0.90	4.60
MIN. MEAN DAILY INFLOW (CFS)	0.70	0.40	0.00	23.60
MONTHLY STORAGE CHANGE	20.00	-25.70	45.10	4,231.70

WATER YEAR 1992-1993	FEBRUARY	MARCH	APRIL	MAY
TOTAL MONTHLY INFLOW (AF)	28,014.30	11,691.80	4,370.40	3,064.40
TOTAL MONTHLY OUTFLOW (AF)	28,897.20	6,189.40	4,330.30	2,911.90
MAX. MEAN DAILY INFLOW (CFS)	2,330.00	320.20	107.20	95.60
TOTAL MONTHLY LOSSES (AF)	7.20	22.70	50.20	71.40
MIN. MEAN DAILY INFLOW (CFS)	102.10	103.70	52.40	29.20
MONTHLY STORAGE CHANGE	-890.10	5,479.70	-10.10	81.10

WATER YEAR 1992-1993	JUNE	JULY	AUGUST	SEPTEMBER
TOTAL MONTHLY INFLOW (AF)	1,717.40	1,068.30	399.40	614.30
TOTAL MONTHLY OUTFLOW (AF)	1,865.50	1,643.30	2,032.70	2,681.30
MAX. MEAN DAILY INFLOW (CFS)	64.70	21.30	13.20	27.70
TOTAL MONTHLY LOSSES (AF)	84.90	94.30	81.80	56.90
MIN. MEAN DAILY INFLOW (CFS)	13.40	11.70	1.80	6.20
MONTHLY STORAGE CHANGE	-233.00	-669.30	-1,715.10	-2,123.90

DEVIL'S GATE DAM AND RESERVOIR

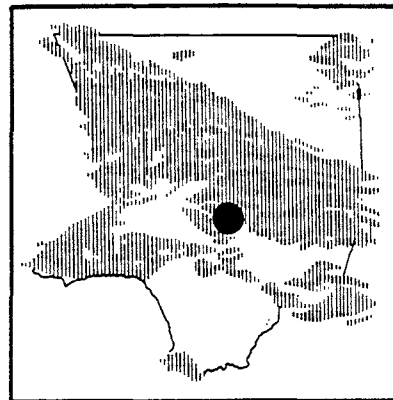
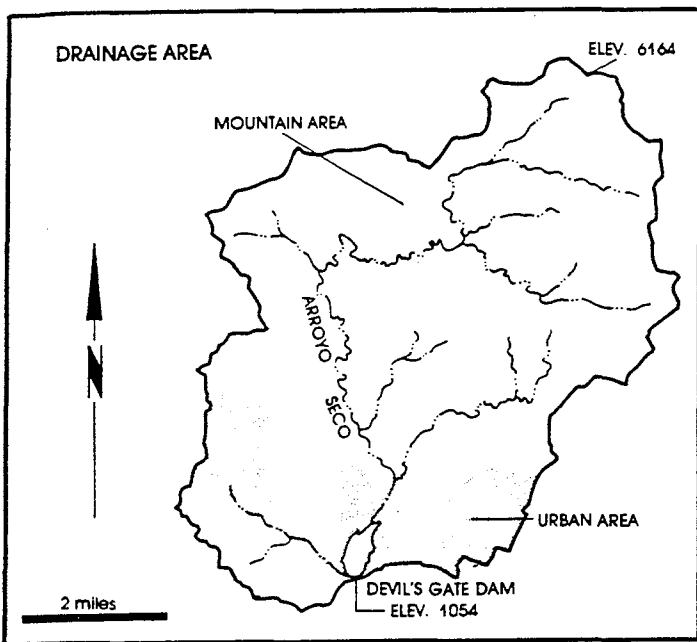

PURPOSE - Flood Control and Conservation.
 DATE CONSTRUCTED - Started May 1919. Completed June 1920.
 LOCATION - On Aroyo Seco, northwest of Pasadena.
 DRAINAGE AREA - 31.9 square miles.
 CAPACITY - 1,928 acre - feet.
 SPILLWAY ELEVATION - 1,054.0 feet.

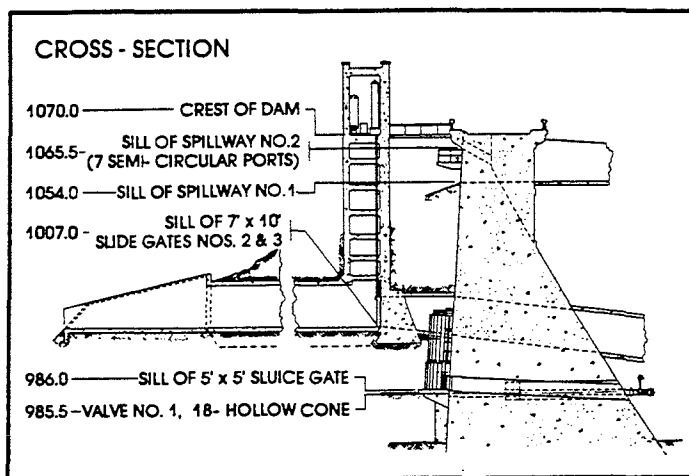

DAM OPERATION RECORD SUMMARY †

MAX. PEAK INFLOW	2212.80 CFS from 1700 on 01-17-93 to 1800 on 01-17-93
MAX. PEAK OUTFLOW	1200.00 CFS from 1030 on 03-26-93 to 1045 on 03-26-93
MAX. W.S. ELEVATION	1042.70 feet on 01-17-93 STORAGE 1548.50 ACRE-FEET
MIN. W.S. ELEVATION	992.00 feet on Varies STORAGE 0.00 ACRE-FEET

† - Values estimated due to incomplete records

DEVIL'S GATE DAM OPERATION RECORD SUMMARY †

WATER YEAR 1992-1993	OCTOBER	NOVEMBER	DECEMBER	JANUARY
TOTAL MONTHLY INFLOW (AF)	528.00	0.00	1,916.20	22,235.20
TOTAL MONTHLY OUTFLOW (AF)	528.00	0.00	1,916.20	22,234.50
MAX. MEAN DAILY INFLOW (CFS)	111.00	0.00	335.60	1,009.70
TOTAL MONTHLY LOSSES (AF)	0.00	0.00	0.00	0.00
MIN. MEAN DAILY INFLOW (CFS)	2.00	0.00	4.30	74.00
MONTHLY STORAGE CHANGE	0.00	0.00	0.00	0.70

WATER YEAR 1992-1993	FEBRUARY	MARCH	APRIL	MAY
TOTAL MONTHLY INFLOW (AF)	18,905.40	12,777.10	2,901.40	1,168.60
TOTAL MONTHLY OUTFLOW (AF)	18,887.20	12,771.60	2,894.80	1,199.60
MAX. MEAN DAILY INFLOW (CFS)	1,134.00	520.80	75.00	45.00
TOTAL MONTHLY LOSSES (AF)	0.00	0.00	0.00	0.00
MIN. MEAN DAILY INFLOW (CFS)	39.70	30.00	0.00	0.00
MONTHLY STORAGE CHANGE	18.20	5.50	6.60	-31.00

WATER YEAR 1992-1993	JUNE	JULY	AUGUST	SEPTEMBER
TOTAL MONTHLY INFLOW (AF)	90.00	99.80	92.20	80.00
TOTAL MONTHLY OUTFLOW (AF)	89.30	99.80	92.20	80.10
MAX. MEAN DAILY INFLOW (CFS)	1.90	2.10	1.50	1.40
TOTAL MONTHLY LOSSES (AF)	0.00	0.00	0.00	0.00
MIN. MEAN DAILY INFLOW (CFS)	0.00	1.50	1.50	1.30
MONTHLY STORAGE CHANGE	0.70	0.00	0.00	-0.10

EATON WASH DAM AND RESERVOIR

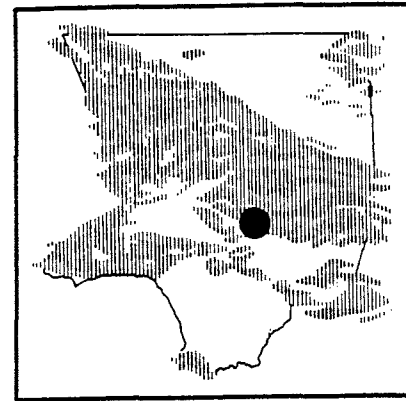
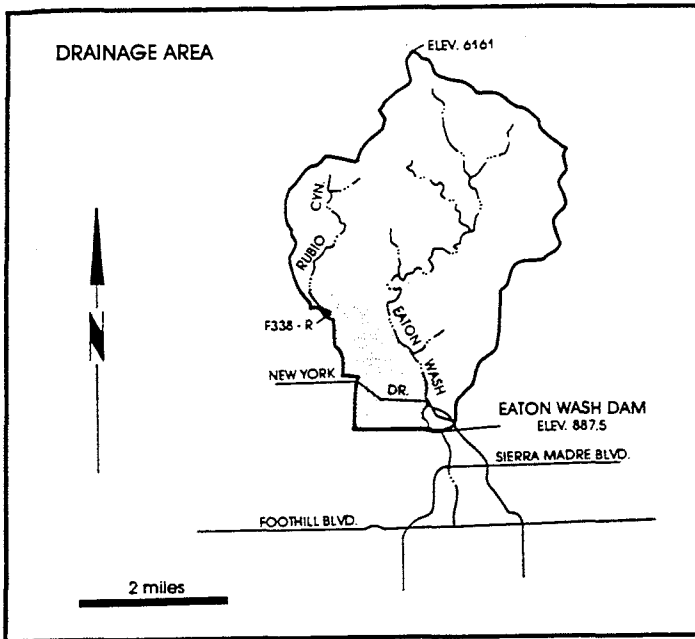

PURPOSE - Debris Storage and Conservation.
DATE CONSTRUCTED - Started January 1936 . Completed February 1937.
LOCATION - Eaton Wash, northeast of Pasadena.
DRAINAGE AREA - 12.4 square miles.
CAPACITY - 879 acre - feet.
SPILLWAY ELEVATION - 887.5 feet.

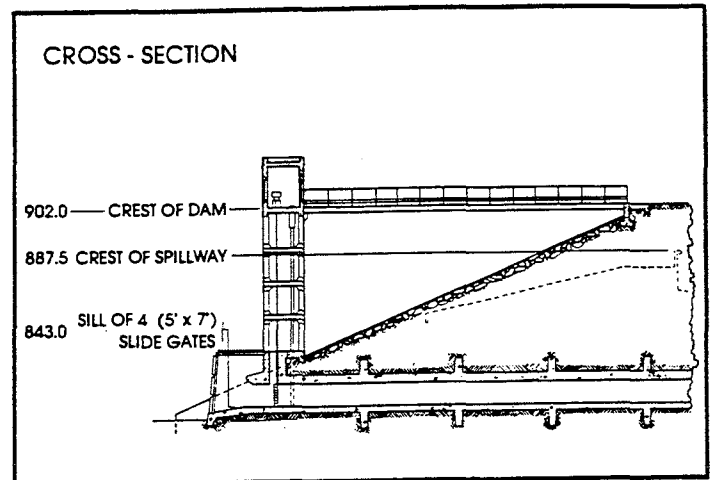

DAM OPERATION RECORD SUMMARY

MAX. PEAK INFLOW	936.99 CFS from 2200 on 01-07-93 to 2300 on 01-07-93
MAX. PEAK OUTFLOW	822.00 CFS from 1030 on 01-07-93 to 2145 on 01-07-93
MAX. W.S. ELEVATION	881.60 feet on 01-19-93 STORAGE 526.80 ACRE-FEET
MIN. W.S. ELEVATION	845.00 feet on 12-15-92 STORAGE 0.00 ACRE-FEET

EATON WASH DAM OPERATION RECORD SUMMARY

WATER YEAR 1992-1993	OCTOBER	NOVEMBER	DECEMBER	JANUARY
TOTAL MONTHLY INFLOW (AF)	5.60	0.80	445.60	5,437.10
TOTAL MONTHLY OUTFLOW (AF)	5.60	0.80	270.50	5,465.70
MAX. MEAN DAILY INFLOW (CFS)	1.10	0.30	106.20	339.90
TOTAL MONTHLY LOSSES (AF)	0.00	0.00	0.00	0.00
MIN. MEAN DAILY INFLOW (CFS)	0.00	0.00	0.00	2.10
MONTHLY STORAGE CHANGE	0.00	0.00	175.10	-28.60

WATER YEAR 1992-1993	FEBRUARY	MARCH	APRIL	MAY
TOTAL MONTHLY INFLOW (AF)	4,390.10	2,536.40	941.50	475.00
TOTAL MONTHLY OUTFLOW (AF)	4,309.10	2,517.20	1,152.00	511.30
MAX. MEAN DAILY INFLOW (CFS)	245.90	163.60	26.40	17.10
TOTAL MONTHLY LOSSES (AF)	0.00	0.00	0.00	0.00
MIN. MEAN DAILY INFLOW (CFS)	7.30	10.10	3.80	0.30
MONTHLY STORAGE CHANGE	81.00	19.20	-210.50	-36.30

WATER YEAR 1992-1993	JUNE	JULY	AUGUST	SEPTEMBER
TOTAL MONTHLY INFLOW (AF)	157.60	105.30	89.90	76.60
TOTAL MONTHLY OUTFLOW (AF)	156.90	105.30	89.90	76.60
MAX. MEAN DAILY INFLOW (CFS)	19.70	2.00	1.60	1.30
TOTAL MONTHLY LOSSES (AF)	0.00	0.00	0.00	0.00
MIN. MEAN DAILY INFLOW (CFS)	0.30	1.50	1.30	0.00
MONTHLY STORAGE CHANGE	0.70	0.00	0.00	0.00

LIVE OAK DAM AND RESERVOIR

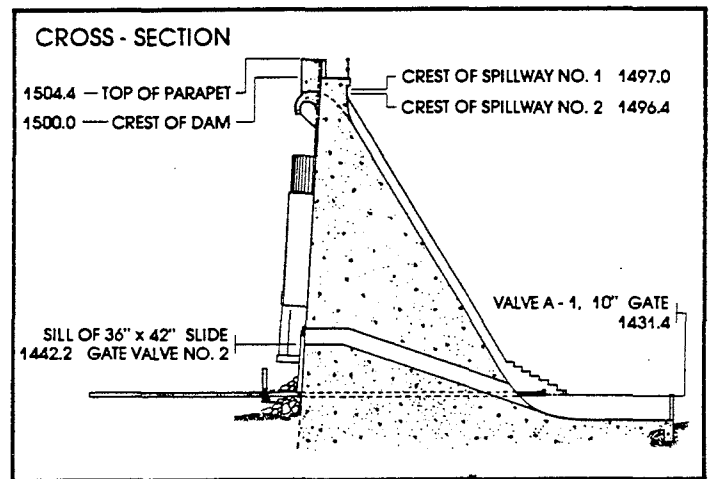
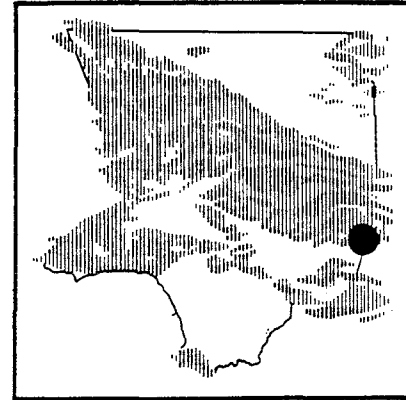
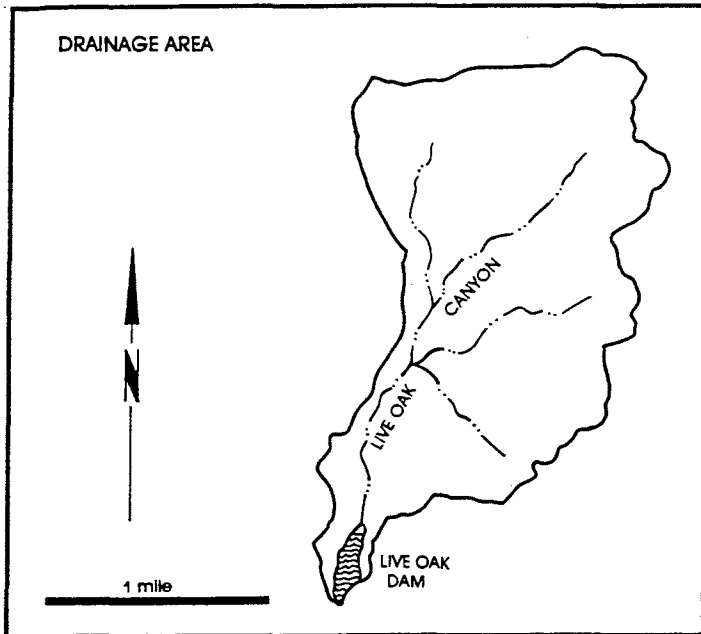

PURPOSE - Flood Control and Conservation.
 DATE CONSTRUCTED - Started August 1921. Completed November 1922.
 LOCATION - 2.5 miles northeast of La Verne.
 DRAINAGE AREA - 2.3 square miles.
 CAPACITY - 240 acre-feet.
 SPILLWAY ELEVATION - 1,496.0 feet.

DAM OPERATION RECORD SUMMARY

MAX. PEAK INFLOW	68.17 CFS from 2200 on 01-07-93 to 2300 on 01-07-93
MAX. PEAK OUTFLOW	79.50 CFS from 1000 on 02-22-93 to 1015 on 02-22-93
MAX. W.S. ELEVATION	1496.55 feet on 03-09-93 STORAGE 240.20 ACRE-FEET
MIN. W.S. ELEVATION	1440.00 feet on Varies STORAGE 0.00 ACRE-FEET

LIVE OAK DAM OPERATION RECORD SUMMARY

WATER YEAR 1992-1993	OCTOBER	NOVEMBER	DECEMBER	JANUARY
TOTAL MONTHLY INFLOW (AF)	1.00	0.00	26.30	766.20
TOTAL MONTHLY OUTFLOW (AF)	0.00	0.40	1.20	770.30
MAX. MEAN DAILY INFLOW (CFS)	0.30	0.00	5.10	55.00
TOTAL MONTHLY LOSSES (AF)	0.00	0.60	0.00	0.00
MIN. MEAN DAILY INFLOW (CFS)	0.00	0.00	0.00	0.00
MONTHLY STORAGE CHANGE	1.00	-1.00	25.10	-4.10

WATER YEAR 1992-1993	FEBRUARY	MARCH	APRIL	MAY
TOTAL MONTHLY INFLOW (AF)	538.60	213.20	113.40	63.70
TOTAL MONTHLY OUTFLOW (AF)	387.60	376.80	31.30	152.10
MAX. MEAN DAILY INFLOW (CFS)	42.50	6.20	5.00	1.90
TOTAL MONTHLY LOSSES (AF)	0.00	0.00	1.60	0.00
MIN. MEAN DAILY INFLOW (CFS)	0.20	0.90	0.10	0.00
MONTHLY STORAGE CHANGE	151.00	-163.60	80.50	-88.40

WATER YEAR 1992-1993	JUNE	JULY	AUGUST	SEPTEMBER
TOTAL MONTHLY INFLOW (AF)	0.20	5.00	16.60	18.10
TOTAL MONTHLY OUTFLOW (AF)	0.00	1.80	0.00	37.30
MAX. MEAN DAILY INFLOW (CFS)	0.10	0.40	0.70	1.60
TOTAL MONTHLY LOSSES (AF)	0.00	0.00	0.00	0.00
MIN. MEAN DAILY INFLOW (CFS)	0.00	0.00	0.10	0.00
MONTHLY STORAGE CHANGE	0.20	3.20	16.60	-19.20

PACOIMA DAM AND RESERVOIR

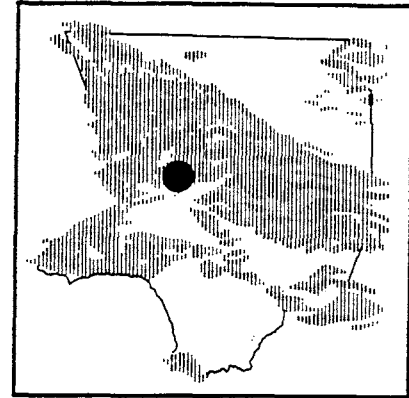
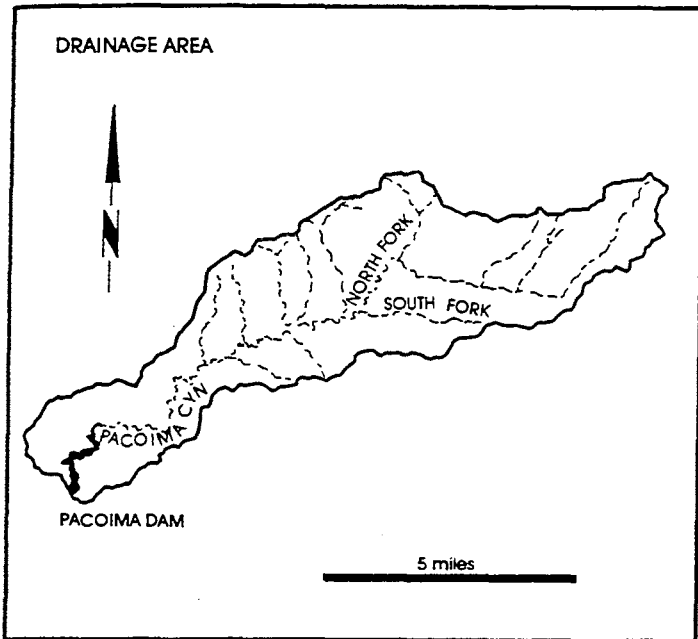

PURPOSE - Flood Control and Conservation.
DATE CONSTRUCTED - Started March 1925. Completed February 1929.
LOCATION - Pacoima Canyon, 4.0 miles northeast of San Fernando.
DRAINAGE AREA - 28.2 square miles.
CAPACITY - 3,929 acre - feet.
SPILLWAY ELEVATION - 1,950.0 feet.

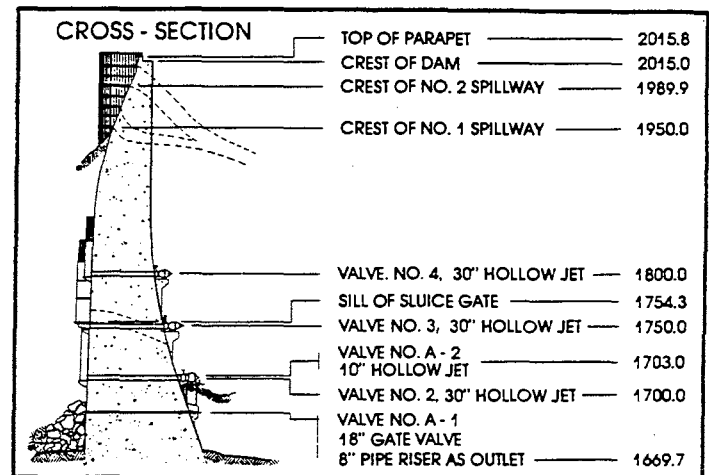

DAM OPERATION RECORD SUMMARY

MAX. PEAK INFLOW	1185.58 CFS from 2100 on 01-13-93 to 2200 on 01-13-93
MAX. PEAK OUTFLOW	745.00 CFS from 1215 on 01-13-93 to 1230 on 01-13-93
MAX. W.S. ELEVATION	1937.90 feet on 01-18-93 STORAGE 3081.40 ACRE-FEET
MIN. W.S. ELEVATION	1878.60 feet on 06-22-93 STORAGE 939.40 ACRE-FEET

PACOIMA DAM OPERATION RECORD SUMMARY

WATER YEAR 1992-1993	OCTOBER	NOVEMBER	DECEMBER	JANUARY
TOTAL MONTHLY INFLOW (AF)	53.20	43.20	496.20	15,269.50
TOTAL MONTHLY OUTFLOW (AF)	0.00	0.00	173.00	13,708.20
MAX. MEAN DAILY INFLOW (CFS)	3.60	1.10	56.90	929.20
TOTAL MONTHLY LOSSES (AF)	12.70	17.10	9.70	16.10
MIN. MEAN DAILY INFLOW (CFS)	0.40	0.10	0.10	16.80
MONTHLY STORAGE CHANGE	40.50	26.10	313.50	1,545.20

WATER YEAR 1992-1993	FEBRUARY	MARCH	APRIL	MAY
TOTAL MONTHLY INFLOW (AF)	13,771.80	6,636.40	2,279.50	811.20
TOTAL MONTHLY OUTFLOW (AF)	14,160.60	6,667.80	2,110.00	1,845.60
MAX. MEAN DAILY INFLOW (CFS)	758.10	260.30	56.80	23.90
TOTAL MONTHLY LOSSES (AF)	12.00	21.60	31.10	24.40
MIN. MEAN DAILY INFLOW (CFS)	51.20	53.80	24.00	10.20
MONTHLY STORAGE CHANGE	-400.80	-53.00	138.40	-1,058.80

WATER YEAR 1992-1993	JUNE	JULY	AUGUST	SEPTEMBER
TOTAL MONTHLY INFLOW (AF)	601.80	287.60	130.20	92.10
TOTAL MONTHLY OUTFLOW (AF)	1,149.00	0.00	0.00	0.00
MAX. MEAN DAILY INFLOW (CFS)	26.70	7.00	3.50	1.90
TOTAL MONTHLY LOSSES (AF)	14.50	13.40	19.10	22.20
MIN. MEAN DAILY INFLOW (CFS)	4.70	3.00	1.20	1.00
MONTHLY STORAGE CHANGE	-561.70	274.20	111.10	69.90

PUDDINGSTONE DAM AND RESERVOIR

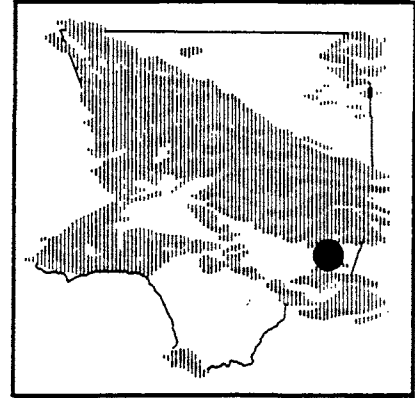
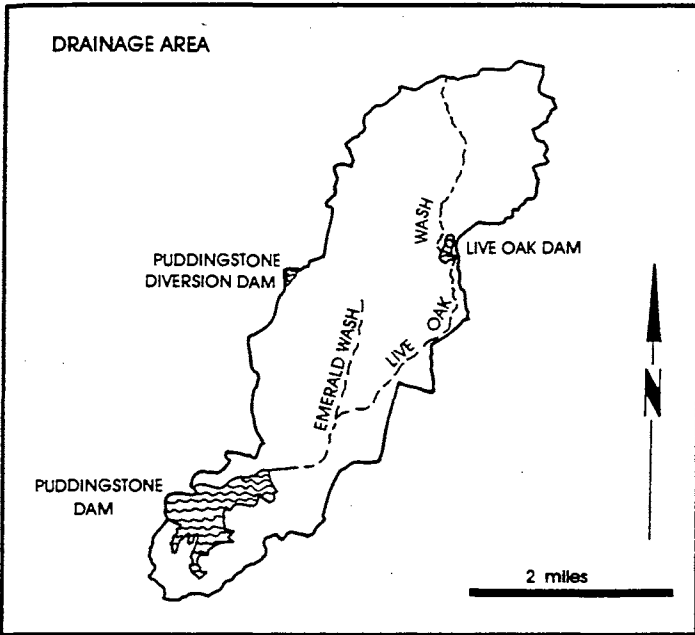

PURPOSE - Flood Control and Recreation.
 DATE CONSTRUCTED - Started February 1925. Completed January 1928.
 LOCATION - 1.0 mile south of San Dimas.
 DRAINAGE AREA - 11.0 square miles (uncontrolled)
 22.1 square miles (controlled)
 Total 33.1 square miles
 CAPACITY - 16,856 acre - feet.
 SPILLWAY ELEVATION - 970.0 feet.

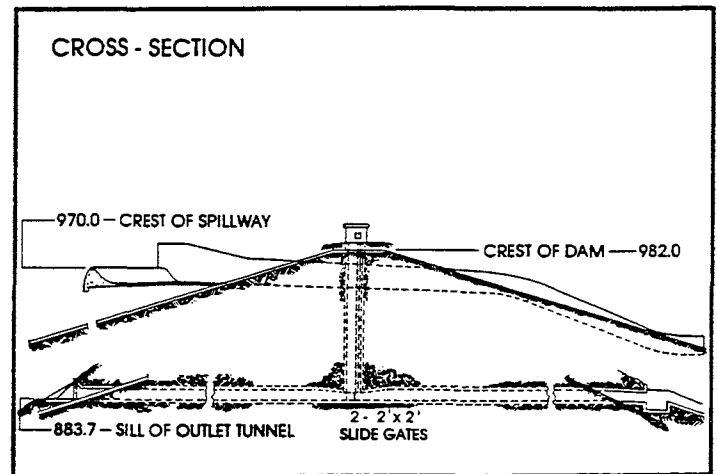

DAM OPERATION RECORD SUMMARY

MAX. PEAK INFLOW	1992.37 CFS from 1200 on 01-18-93 to 1300 on 01-18-93
MAX. PEAK OUTFLOW	863.00 CFS from 1545 on 02-19-93 to 1600 on 02-19-93
MAX. W.S. ELEVATION	945.07 feet on 01-08-93 STORAGE 7360.70 ACRE-FEET
MIN. W.S. ELEVATION	938.96 feet on 02-17-93 STORAGE 5814.50 ACRE-FEET

PUDDINGSTONE DAM OPERATION RECORD SUMMARY

WATER YEAR 1992-1993	OCTOBER	NOVEMBER	DECEMBER	JANUARY
TOTAL MONTHLY INFLOW (AF)	361.40	60.40	1,582.60	12,162.50
TOTAL MONTHLY OUTFLOW (AF)	16.90	12.10	1,127.00	12,302.30
MAX. MEAN DAILY INFLOW (CFS)	100.70	3.40	255.00	909.40
TOTAL MONTHLY LOSSES (AF)	113.20	88.80	140.50	37.60
MIN. MEAN DAILY INFLOW (CFS)	0.40	0.00	0.30	0.10
MONTHLY STORAGE CHANGE	231.30	-40.50	315.10	-177.40

WATER YEAR 1992-1993	FEBRUARY	MARCH	APRIL	MAY
TOTAL MONTHLY INFLOW (AF)	11,666.30	2,861.40	631.10	239.00
TOTAL MONTHLY OUTFLOW (AF)	11,970.40	2,182.00	712.90	27.20
MAX. MEAN DAILY INFLOW (CFS)	602.80	122.70	23.30	16.30
TOTAL MONTHLY LOSSES (AF)	39.90	76.70	138.80	163.90
MIN. MEAN DAILY INFLOW (CFS)	3.80	13.10	0.00	0.50
MONTHLY STORAGE CHANGE	-344.00	602.70	-220.60	47.90

WATER YEAR 1992-1993	JUNE	JULY	AUGUST	SEPTEMBER
TOTAL MONTHLY INFLOW (AF)	423.30	105.50	132.50	98.30
TOTAL MONTHLY OUTFLOW (AF)	244.60	25.80	28.60	23.80
MAX. MEAN DAILY INFLOW (CFS)	51.50	3.60	3.80	3.20
TOTAL MONTHLY LOSSES (AF)	201.60	177.60	191.80	167.10
MIN. MEAN DAILY INFLOW (CFS)	0.10	0.40	0.70	0.40
MONTHLY STORAGE CHANGE	-22.90	-97.90	-87.90	-92.60

PUDDINGSTONE DIVERSION DAM AND RESERVOIR

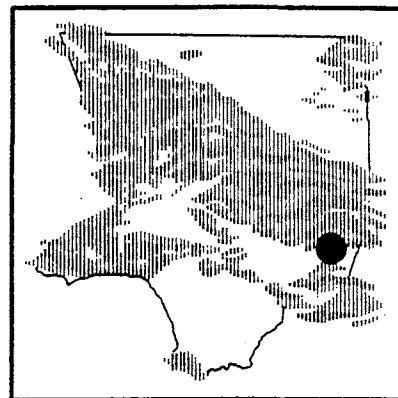
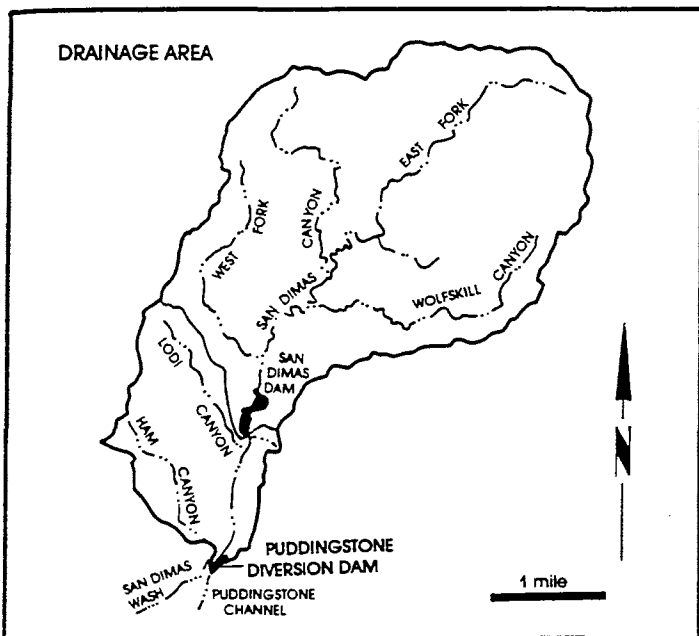

PURPOSE - Flood Control and Diversion of flow and Conservation.
DATE CONSTRUCTED - Started September 1927. Completed July 1928.
LOCATION - 2.0 miles northeast of San Dimas.
DRAINAGE AREA - 3.7 square miles (uncontrolled)
 16.2 square miles (controlled)
 Total 19.9 square miles
CAPACITY - 148 acre feet.
SPILLWAY ELEVATION - 1,152.0 feet.

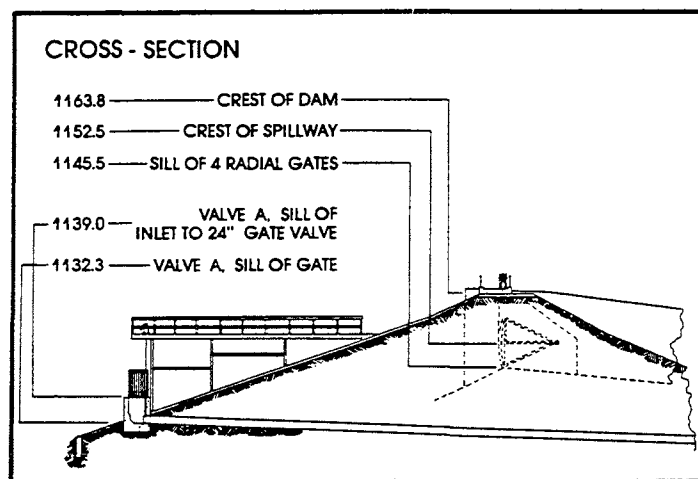

DAM OPERATION RECORD SUMMARY

MAX. PEAK INFLOW	756.55 CFS from 0800 on 01-18-93 to 0900 on 01-18-93
MAX. PEAK OUTFLOW	787.00 CFS from 0800 on 01-18-93 to 0900 on 01-18-93
MAX. W.S. ELEVATION	1147.80 feet on 01-18-93 STORAGE 125.80 ACRE-FEET
MIN. W.S. ELEVATION	1133.00 feet on Varies STORAGE 0.00 ACRE-FEET

PUDD. DIVERSION DAM OPERATION RECORD SUMMARY

WATER YEAR 1992-1993	OCTOBER	NOVEMBER	DECEMBER	JANUARY
TOTAL MONTHLY INFLOW (AF)	55.20	20.10	400.90	9,286.60
TOTAL MONTHLY OUTFLOW (AF)	0.80	41.90	341.20	9,259.60
MAX. MEAN DAILY INFLOW (CFS)	15.70	2.50	71.80	698.00
TOTAL MONTHLY LOSSES (AF)	0.00	8.90	0.80	6.30
MIN. MEAN DAILY INFLOW (CFS)	0.00	0.00	0.00	4.40
MONTHLY STORAGE CHANGE	54.40	-30.70	58.90	20.70

WATER YEAR 1992-1993	FEBRUARY	MARCH	APRIL	MAY
TOTAL MONTHLY INFLOW (AF)	8,184.60	4,505.80	1,644.20	865.00
TOTAL MONTHLY OUTFLOW (AF)	8,178.20	4,512.60	1,644.90	915.00
MAX. MEAN DAILY INFLOW (CFS)	332.70	160.50	44.00	30.60
TOTAL MONTHLY LOSSES (AF)	0.10	0.00	0.40	0.00
MIN. MEAN DAILY INFLOW (CFS)	21.70	44.00	0.00	2.60
MONTHLY STORAGE CHANGE	6.30	-6.80	-1.10	-50.00

WATER YEAR 1992-1993	JUNE	JULY	AUGUST	SEPTEMBER
TOTAL MONTHLY INFLOW (AF)	579.40	171.90	0.20	0.00
TOTAL MONTHLY OUTFLOW (AF)	625.20	166.00	0.20	0.00
MAX. MEAN DAILY INFLOW (CFS)	20.00	8.00	0.10	0.00
TOTAL MONTHLY LOSSES (AF)	0.00	11.90	0.00	0.00
MIN. MEAN DAILY INFLOW (CFS)	7.30	0.00	0.00	0.00
MONTHLY STORAGE CHANGE	-45.80	-6.00	0.00	0.00

SAN DIMAS DAM AND RESERVOIR

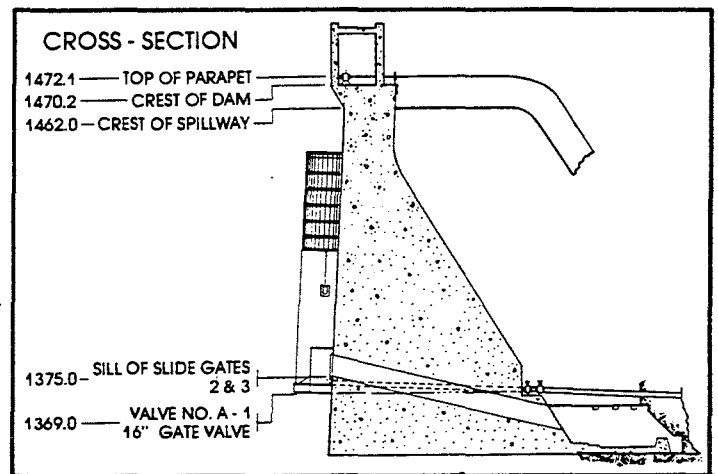
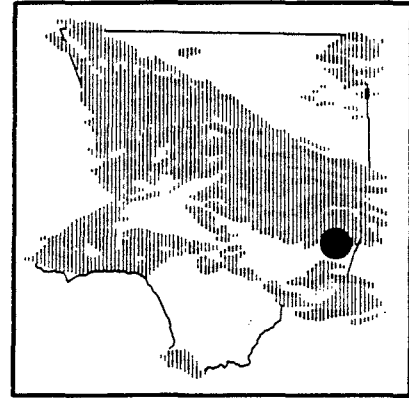
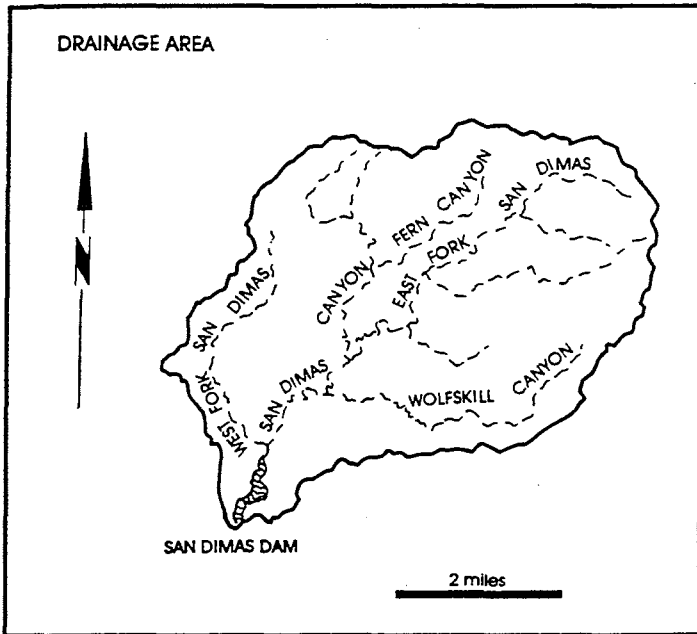

PURPOSE - Flood Control and Conservation.
 DATE CONSTRUCTED - Started November 1920. Completed September 1922.
 LOCATION - 3.0 miles northeast of San Dimas.
 DRAINAGE AREA - 16.2 square miles.
 CAPACITY - 1,515 acre - feet.
 SPILLWAY ELEVATION - 1,462.0 feet.

DAM OPERATION RECORD SUMMARY

MAX. PEAK INFLOW	945.44 CFS from 0300 on 01-14-93 to 0400 on 01-14-93
MAX. PEAK OUTFLOW	651.00 CFS from 1300 on 01-18-93 to 1315 on 01-18-93
MAX. W.S. ELEVATION	1456.60 feet on 01-18-93 STORAGE 1366.10 ACRE-FEET
MIN. W.S. ELEVATION	1391.00 feet on Varies STORAGE 0.00 ACRE-FEET

SAN DIMAS DAM OPERATION RECORD SUMMARY

WATER YEAR 1992-1993	OCTOBER	NOVEMBER	DECEMBER	JANUARY
TOTAL MONTHLY INFLOW (AF)	49.10	28.80	439.50	10,049.80
TOTAL MONTHLY OUTFLOW (AF)	56.70	28.80	439.10	9,663.70
MAX. MEAN DAILY INFLOW (CFS)	11.80	0.90	47.70	650.50
TOTAL MONTHLY LOSSES (AF)	0.90	0.00	0.00	2.50
MIN. MEAN DAILY INFLOW (CFS)	0.00	0.30	1.00	7.10
MONTHLY STORAGE CHANGE	-8.50	0.00	0.40	383.60

WATER YEAR 1992-1993	FEBRUARY	MARCH	APRIL	MAY
TOTAL MONTHLY INFLOW (AF)	7,194.70	3,406.60	1,326.30	876.50
TOTAL MONTHLY OUTFLOW (AF)	7,362.40	3,598.60	1,307.70	914.20
MAX. MEAN DAILY INFLOW (CFS)	574.10	102.30	31.70	20.30
TOTAL MONTHLY LOSSES (AF)	1.90	0.80	2.20	0.30
MIN. MEAN DAILY INFLOW (CFS)	15.20	26.40	13.30	6.40
MONTHLY STORAGE CHANGE	-169.60	-192.80	16.40	-38.00

WATER YEAR 1992-1993	JUNE	JULY	AUGUST	SEPTEMBER
TOTAL MONTHLY INFLOW (AF)	452.60	705.80	224.40	187.30
TOTAL MONTHLY OUTFLOW (AF)	452.60	575.20	25.00	21.60
MAX. MEAN DAILY INFLOW (CFS)	12.30	26.20	6.10	5.00
TOTAL MONTHLY LOSSES (AF)	0.00	2.10	10.10	10.30
MIN. MEAN DAILY INFLOW (CFS)	7.00	4.10	0.50	0.70
MONTHLY STORAGE CHANGE	0.00	128.50	189.30	155.40

SAN GABRIEL DAM AND RESERVOIR

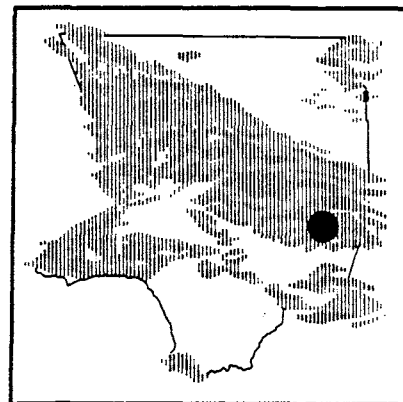
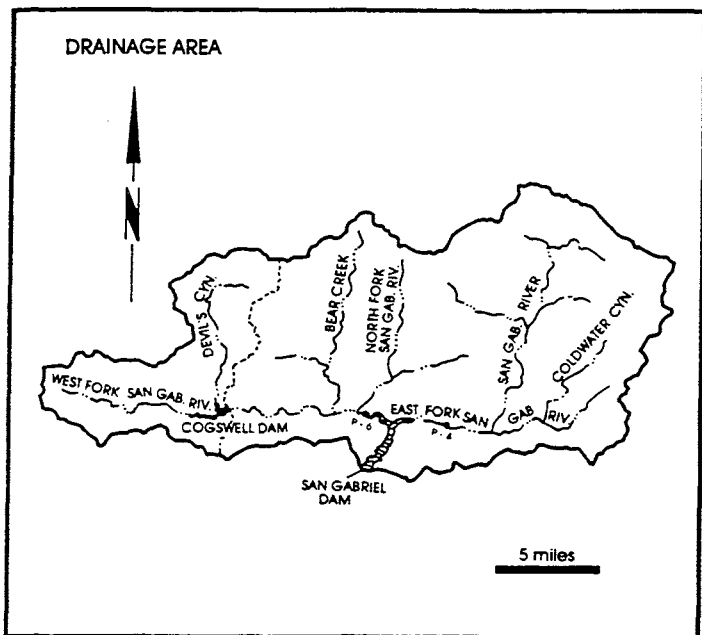

PURPOSE - Flood Control and Conservation.
DATE CONSTRUCTED - Started December 1932. Completed July 1939.
LOCATION - San Gabriel Canyon, 7.5 miles north of Azusa.
DRAINAGE AREA - 163.5 square miles (uncontrolled)
 39.2 square miles (controlled)
 Total 202.7 square miles
 (Includes Cogswell drainage)
CAPACITY - 41,549 acre - feet.
SPILLWAY ELEVATION - 1,453 feet.

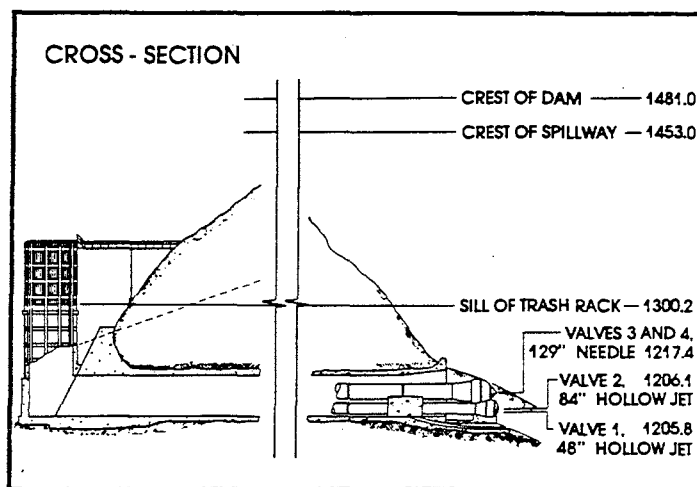

DAM OPERATION RECORD SUMMARY

MAX. PEAK INFLOW	12934.21 CFS from 0600 on 02-19-93 to 0700 on 02-19-93
MAX. PEAK OUTFLOW	11857.70 CFS from 0800 on 01-14-93 to 0815 on 01-14-93
MAX. W.S. ELEVATION	1453.62 feet on 04-04-93 STORAGE 44517.00 ACRE- FEET
MIN W.S. ELEVATION	1279.00 feet on Varies STORAGE 0.00 ACRE- FEET

SAN GABRIEL DAM OPERATION RECORD SUMMARY

WATER YEAR 1992-1993	OCTOBER	NOVEMBER	DECEMBER	JANUARY
TOTAL MONTHLY INFLOW (AF)	0.00	0.20	2,640.60	146,957.80
TOTAL MONTHLY OUTFLOW (AF)	0.00	0.00	2.60	121,549.30
MAX. MEAN DAILY INFLOW (CFS)	0.00	0.00	497.10	8,035.40
TOTAL MONTHLY LOSSES (AF)	0.00	0.10	9.00	79.00
MIN. MEAN DAILY INFLOW (CFS)	0.00	0.00	0.00	139.10
MONTHLY STORAGE CHANGE	0.00	0.10	2,629.00	25,329.50

WATER YEAR 1992-1993	FEBRUARY	MARCH	APRIL	MAY
TOTAL MONTHLY INFLOW (AF)	137,757.20	61,615.10	36,255.70	25,613.40
TOTAL MONTHLY OUTFLOW (AF)	132,127.30	51,423.10	36,790.80	22,122.40
MAX. MEAN DAILY INFLOW (CFS)	10,181.10	2,838.50	901.70	1,210.30
TOTAL MONTHLY LOSSES (AF)	80.80	178.00	266.70	319.80
MIN. MEAN DAILY INFLOW (CFS)	613.60	206.80	368.30	305.50
MONTHLY STORAGE CHANGE	5,549.10	10,014.00	-801.80	3,171.20

WATER YEAR 1992-1993	JUNE	JULY	AUGUST	SEPTEMBER
TOTAL MONTHLY INFLOW (AF)	14,669.50	9,017.90	5,739.90	4,804.30
TOTAL MONTHLY OUTFLOW (AF)	16,578.80	15,435.80	16,995.20	16,589.20
MAX. MEAN DAILY INFLOW (CFS)	405.50	186.40	129.00	149.30
TOTAL MONTHLY LOSSES (AF)	341.50	318.10	330.90	220.30
MIN. MEAN DAILY INFLOW (CFS)	175.70	80.30	65.90	11.30
MONTHLY STORAGE CHANGE	-2,250.80	-6,736.00	-11,586.20	-12,005.20

SANTA ANITA DAM AND RESERVOIR

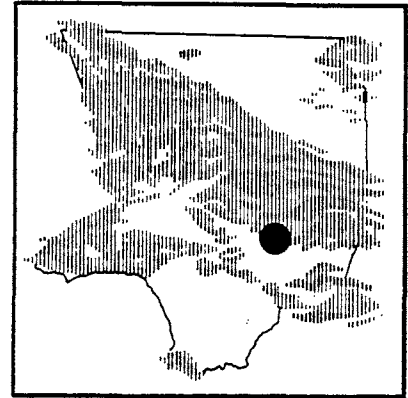
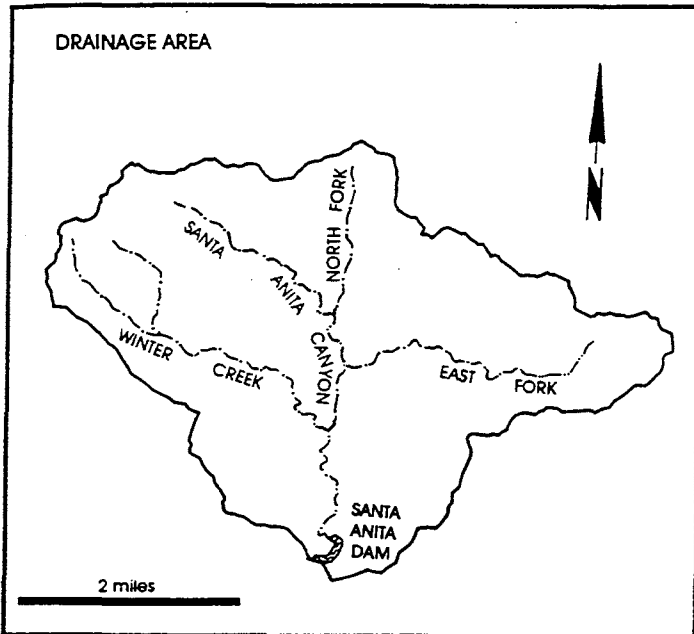

PURPOSE - Flood Control and Conservation.
 DATE CONSTRUCTED - Started October 1924. Completed March 1927.
 LOCATION - 2.5 miles north of Arcadia
 DRAINAGE AREA - 10.8 square miles.
 CAPACITY - 836 acre - feet.
 SPILLWAY ELEVATION - 1,316.0 feet.

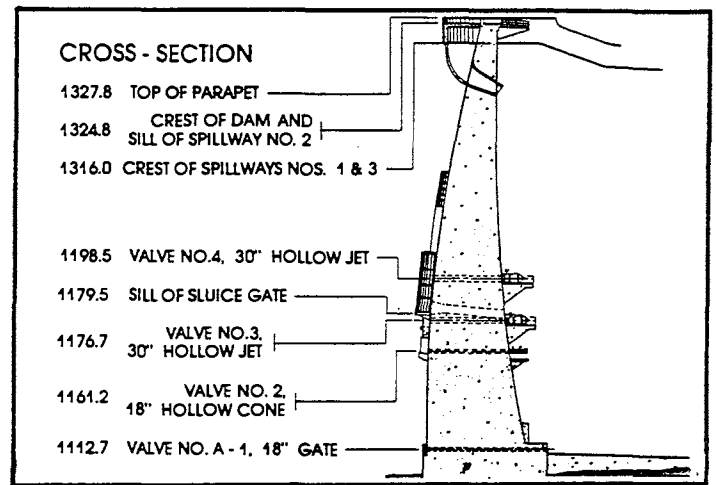

DAM OPERATION RECORD SUMMARY

MAX. PEAK INFLOW	908.86 CFS from 2100 on 01-07-93 to 2200 on 01-07-93
MAX. PEAK OUTFLOW	588.00 CFS from 1445 on 01-18-93 to 1500 on 01-18-93
MAX. W.S. ELEVATION	1295.40 feet on 01-18-93 STORAGE 584.30 ACRE-FEET
MIN. W.S. ELEVATION	1186.00 feet on Varies STORAGE 0.00 ACRE-FEET

SANTA ANITA DAM OPERATION RECORD SUMMARY

WATER YEAR 1992-1993	OCTOBER	NOVEMBER	DECEMBER	JANUARY
TOTAL MONTHLY INFLOW (AF)	203.30	160.80	1,190.20	9,129.10
TOTAL MONTHLY OUTFLOW (AF)	216.90	281.40	1,286.40	9,134.10
MAX. MEAN DAILY INFLOW (CFS)	22.70	8.80	66.70	558.10
TOTAL MONTHLY LOSSES (AF)	2.30	1.80	0.30	0.30
MIN. MEAN DAILY INFLOW (CFS)	0.20	0.80	2.40	14.10
MONTHLY STORAGE CHANGE	-15.90	-122.40	-96.50	-5.30

WATER YEAR 1992-1993	FEBRUARY	MARCH	APRIL	MAY
TOTAL MONTHLY INFLOW (AF)	6,318.40	3,318.10	1,235.70	727.50
TOTAL MONTHLY OUTFLOW (AF)	6,290.50	2,973.20	1,324.90	707.10
MAX. MEAN DAILY INFLOW (CFS)	342.30	90.00	30.80	17.20
TOTAL MONTHLY LOSSES (AF)	0.00	0.90	1.60	3.00
MIN. MEAN DAILY INFLOW (CFS)	41.70	30.20	10.10	10.30
MONTHLY STORAGE CHANGE	27.90	344.00	-90.80	17.40

WATER YEAR 1992-1993	JUNE	JULY	AUGUST	SEPTEMBER
TOTAL MONTHLY INFLOW (AF)	574.80	376.80	183.60	127.90
TOTAL MONTHLY OUTFLOW (AF)	651.20	512.70	124.40	78.20
MAX. MEAN DAILY INFLOW (CFS)	18.70	9.50	6.00	5.10
TOTAL MONTHLY LOSSES (AF)	3.10	1.60	2.00	2.40
MIN. MEAN DAILY INFLOW (CFS)	6.60	4.10	1.00	0.50
MONTHLY STORAGE CHANGE	-79.50	-137.50	57.20	47.30

SAWPIT DAM AND RESERVOIR

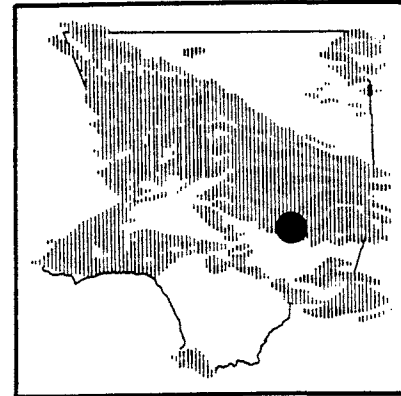
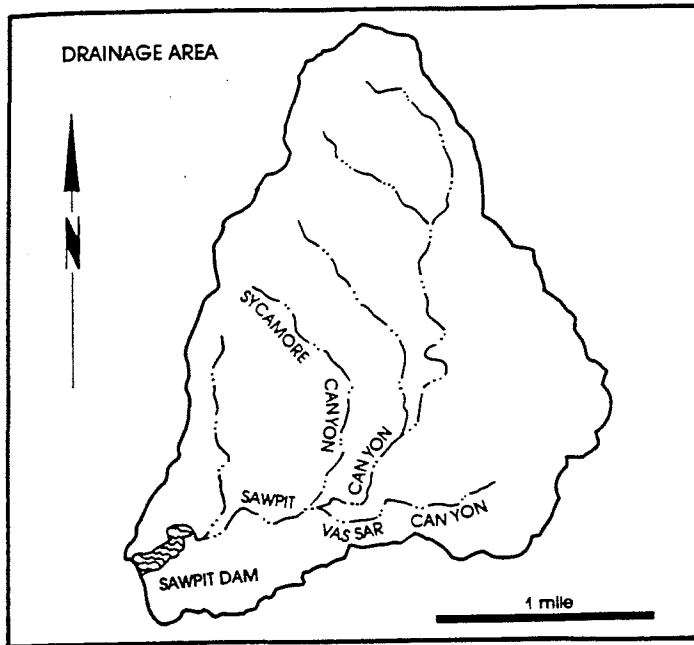

PURPOSE - Flood Control and Conservation.
 DATE CONSTRUCTED - Started March 1926. Completed June 1927.
 LOCATION - 2.0 miles north of Monrovia.
 DRAINAGE AREA - 3.2 square miles.
 CAPACITY - 391 acre - feet.
 SPILLWAY ELEVATION - 1,360.0 feet.

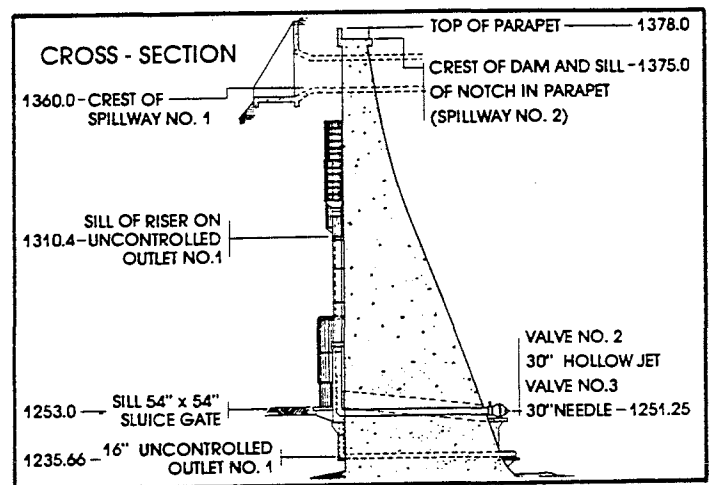

DAM OPERATION RECORD SUMMARY

MAX. PEAK INFLOW	201.85 CFS from 2300 on 01-07-93 to 2400 on 01-07-93
MAX. PEAK OUTFLOW	68.70 CFS from 2145 on 02-20-93 to 2200 on 02-20-93
MAX. W.S. ELEVATION	1328.50 feet on 01-08-93 STORAGE 177.30 ACRE- FEET
MIN. W.S. ELEVATION	1259.00 feet on 10-21-92 STORAGE 0.00 ACRE- FEET

SAWPIT DAM OPERATION RECORD SUMMARY

WATER YEAR 1992-1993	OCTOBER	NOVEMBER	DECEMBER	JANUARY
TOTAL MONTHLY INFLOW (AF)	41.90	62.00	191.40	1,246.00
TOTAL MONTHLY OUTFLOW (AF)	41.80	61.90	191.00	1,245.20
MAX. MEAN DAILY INFLOW (CFS)	5.50	2.00	13.20	63.10
TOTAL MONTHLY LOSSES (AF)	0.00	0.00	0.00	0.00
MIN. MEAN DAILY INFLOW (CFS)	0.40	0.90	0.90	2.30
MONTHLY STORAGE CHANGE	0.10	0.10	0.40	0.80

WATER YEAR 1992-1993	FEBRUARY	MARCH	APRIL	MAY
TOTAL MONTHLY INFLOW (AF)	1,309.70	938.40	568.60	429.80
TOTAL MONTHLY OUTFLOW (AF)	1,305.90	942.30	568.70	429.80
MAX. MEAN DAILY INFLOW (CFS)	67.40	34.00	10.00	8.00
TOTAL MONTHLY LOSSES (AF)	0.00	0.00	0.00	0.00
MIN. MEAN DAILY INFLOW (CFS)	7.90	9.90	8.00	6.00
MONTHLY STORAGE CHANGE	3.80	-3.90	-0.10	0.00

WATER YEAR 1992-1993	JUNE	JULY	AUGUST	SEPTEMBER
TOTAL MONTHLY INFLOW (AF)	295.10	192.60	169.00	119.00
TOTAL MONTHLY OUTFLOW (AF)	295.10	193.00	169.40	119.00
MAX. MEAN DAILY INFLOW (CFS)	6.00	4.00	3.00	2.00
TOTAL MONTHLY LOSSES (AF)	0.00	0.00	0.00	0.00
MIN. MEAN DAILY INFLOW (CFS)	4.00	2.90	2.00	2.00
MONTHLY STORAGE CHANGE	0.00	-0.40	-0.40	0.00

THOMPSON CREEK DAM AND RESERVOIR

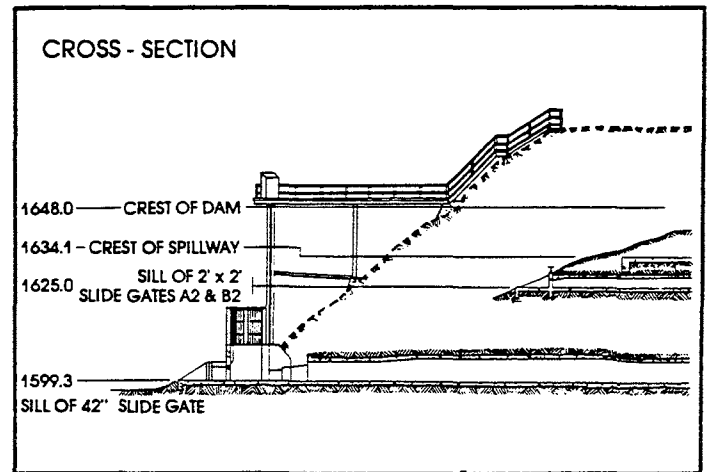
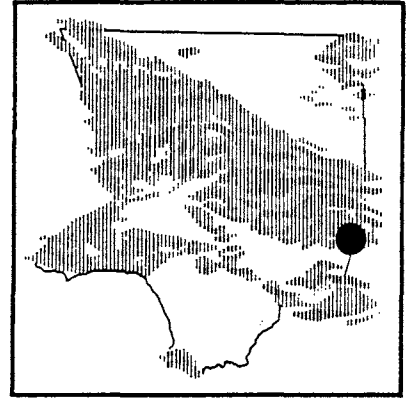
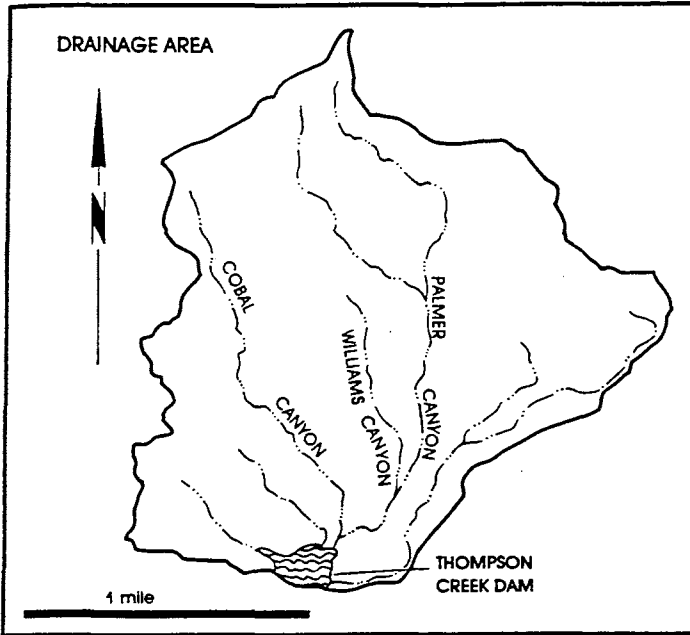

PURPOSE - Flood Control and Conservation.
DATE CONSTRUCTED - Started September 1925. Completed March 1928.
LOCATION - 3.0 miles north of Claremont.
DRAINAGE AREA - 3.5 square miles.
CAPACITY - 447.5 acre - feet.
SPILLWAY ELEVATION - 1,634 feet.

DAM OPERATION RECORD SUMMARY

MAX. PEAK INFLOW	166.02 CFS from 0800 on 01-18-93 to 0900 on 01-18-93
MAX. PEAK OUTFLOW	187.10 CFS from 0945 on 01-18-93 to 1000 on 01-18-93
MAX. W.S. ELEVATION	1612.10 feet on 01-14-93 STORAGE 112.40 ACRE-FEET
MIN. W.S. ELEVATION	1600.00 feet on Varies STORAGE 0.00 ACRE-FEET

THOMPSON CREEK DAM OPERATION RECORD SUMMARY

WATER YEAR 1992-1993	OCTOBER	NOVEMBER	DECEMBER	JANUARY
TOTAL MONTHLY INFLOW (AF)	0.60	0.00	16.90	731.70
TOTAL MONTHLY OUTFLOW (AF)	0.60	0.00	1.00	682.10
MAX. MEAN DAILY INFLOW (CFS)	0.20	0.00	4.40	44.50
TOTAL MONTHLY LOSSES (AF)	0.00	0.00	0.00	7.10
MIN. MEAN DAILY INFLOW (CFS)	0.00	0.00	0.00	0.00
MONTHLY STORAGE CHANGE	0.00	0.00	15.90	42.50

WATER YEAR 1992-1993	FEBRUARY	MARCH	APRIL	MAY
TOTAL MONTHLY INFLOW (AF)	471.80	46.20	0.00	0.00
TOTAL MONTHLY OUTFLOW (AF)	446.70	67.40	3.80	0.00
MAX. MEAN DAILY INFLOW (CFS)	57.00	8.10	0.00	0.00
TOTAL MONTHLY LOSSES (AF)	5.40	10.30	38.70	1.50
MIN. MEAN DAILY INFLOW (CFS)	0.00	0.00	0.00	0.00
MONTHLY STORAGE CHANGE	19.70	-31.50	-42.50	-1.50

WATER YEAR 1992-1993	JUNE	JULY	AUGUST	SEPTEMBER
TOTAL MONTHLY INFLOW (AF)	0.00	0.00	0.00	0.00
TOTAL MONTHLY OUTFLOW (AF)	0.00	0.00	0.00	0.00
MAX. MEAN DAILY INFLOW (CFS)	0.00	0.00	0.00	0.00
TOTAL MONTHLY LOSSES (AF)	0.00	0.00	0.00	0.00
MIN. MEAN DAILY INFLOW (CFS)	0.00	0.00	0.00	0.00
MONTHLY STORAGE CHANGE	0.00	0.00	0.00	0.00

EROSION CONTROL

EROSION CONTROL

Each year eroded material in various forms (trees, rock, sand, etc.) flows out of the mountain watersheds of Los Angeles County. In an effort to control this potentially disruptive force, the Department maintains a series of debris basins in canyon mouths and upstream stabilization structures in selected watersheds.

DEBRIS BASINS

The purpose of a debris basin is to entrap the debris flows emanating from the canyon and let the relatively desilted water pass into the flood control channels.

In the 1992-1993 water year, the Department maintained 114 debris basins. The total maximum capacity of the basins is approximately 7,608,450 cubic yards.

The Department cleaned out 31 debris basins.

Records of sediment inflow at individual debris basins and amounts excavated and removed are available in the Hydraulic/Water Conservation Division.

STABILIZATION STRUCTURES

Stabilization structures are constructed to control erosion in natural canyons. They serve to prevent downcutting by stabilizing alluvium deposits. In addition, they store debris generated by the watershed and serve to stabilize side banks, reducing side slope sloughing and bank erosion.

The Department maintains 225 stabilization structures in 47 major watersheds. No structures have been constructed since the 1973-74 water year.

EMERGENCY STRUCTURES

Emergency structures (rail and timber, and crib type) have been constructed to entrap the debris inflow from burned watersheds. They serve to protect improvements (road, channel, residence, etc.) located immediately downstream of the watersheds. Currently, 34 emergency structures exist with a total maximum capacity of 269,600 cubic yards. Four major fires (over 500 acres) burned 4,066 acres in this water year and are shown on the Burned Area Location Map on page PE2.

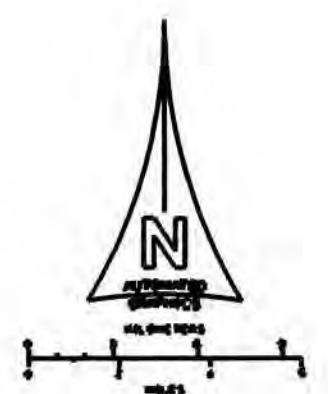
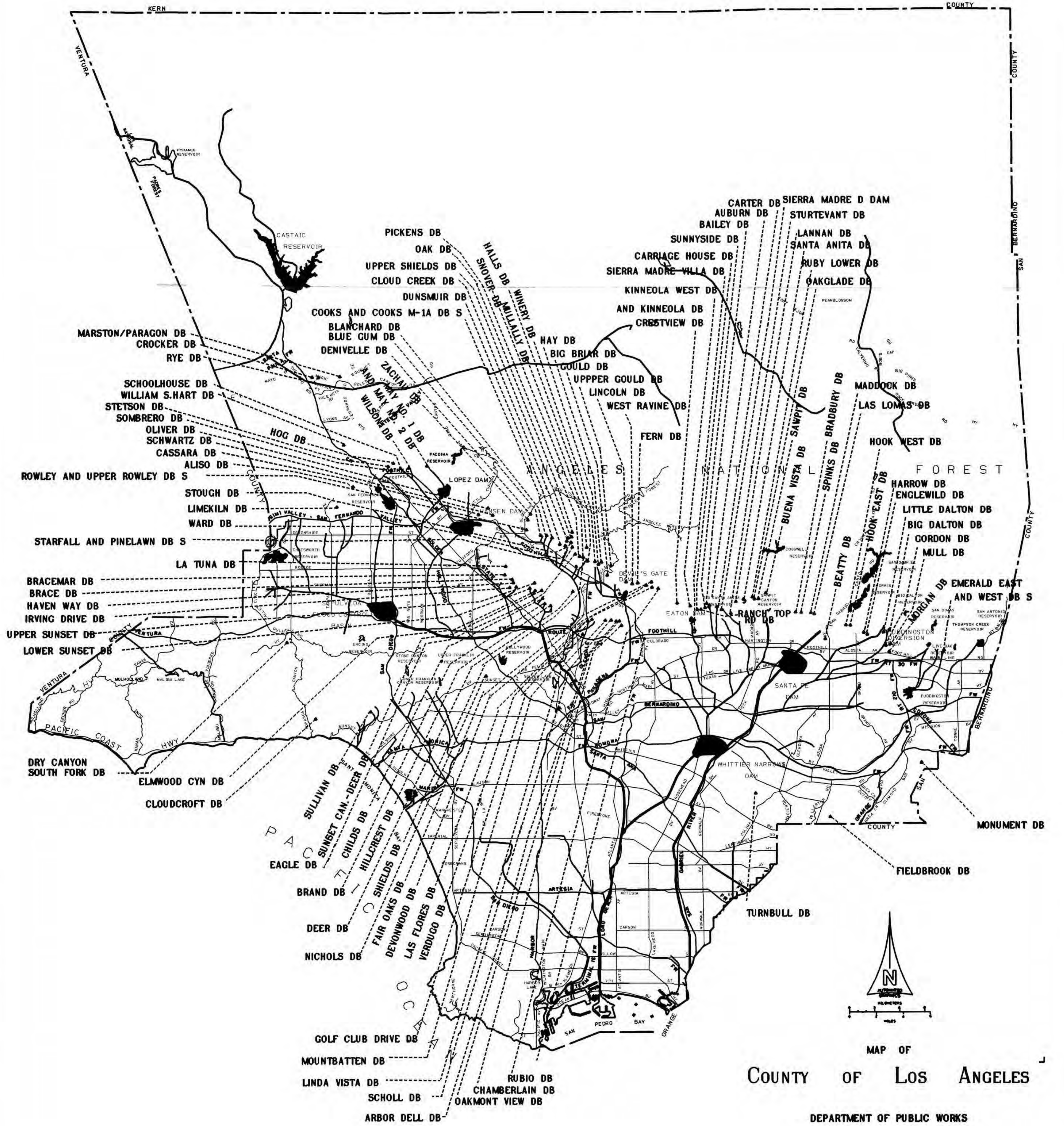

MAP OF
COUNTY OF LOS ANGELES

DEPARTMENT OF PUBLIC WORKS
 DEBRIS BASIN LOCATIONS

UPDATED FEBRUARY 2, 1994

LOS ANGELES COUNTY DEPARTMENT OF PUBLIC WORKS

DATA SHEET A

DEBRIS BASIN - DESIGN DATA

Including 1992-1993 Storm Season

Compiled by: Hydraulic and Water Conservation
Division - Sedimentation Management
Date: November 30, 1993
FILE: DSA93.WK3

DEBRIS BASIN	FIRST DEBRIS SEASON	UNCONTROLLED DRAINAGE AREA ABOVE BASIN (SQ. MI.)	BOTTOM ELEV. AT MAX CAP. (FT.)	ELEV PORT INVERT (FT.)	ELEV. SPILLWAY CREST (FT.)	WIDTH SPILLWAY (FT.)	ELEV. CREST OF DAM (FT.)	MAX. DEB. CAP. (CU. YDS.)
Aliso	1970 - 71	2.77	1108	1108.4	1120.0	70.0	1134.0	41,700 (8)
Arbor Dell	1971 - 72	0.11	898.7	898.4	913.0	22.9	919.8	12,400
Auburn	1954 - 55	0.19	1263.9	1263.0	1275.0	30.0	1283.0	31,600
Bailey	1945 - 46	0.60	1123	1123.1	1155.0	30.0	1166.0	128,800
Beatty	1970 - 71	0.27	800	800.0	807.0	32.0	815.5	43,000
Bigbriar	1971 - 72	0.02	1898.3	1896.0	1910.0	14.0	1910.8	2,600
Big Dalton	1959 - 60	2.94	1102	1101.9 (3)	1131.5	116.0	1148.7	517,800
Blanchard	1968 - 69	0.47	2026	2026.0	2053.5	40.0	2065.0	74,500
Blue Gum	1968 - 69	0.19	2020	2020.0	2042.0	25.0	2053.0	39,600
Brace	1971 - 72	0.29	1189.7	1189.7	1194.5	20.0	1203.3	27,500
Bracemar	1971 - 72	0.01	1140	1140.0	1145.5	8.0	1148.0	700 (16)
Bradbury	1954 - 55	0.68	912.5	913.1	920.0	58.0	928.0	89,800
Brand	1935 - 36	1.04	860	860.0	890.0	60.0	903.0	166,000
Buena Vista	1985 - 86	0.10	978.7	978.7	992.2	39.0	997.7	21,400
Carriage House	1970 - 71	0.03	1350.3	1350.0	1362.9	15.0	1366.8	6,100
Carter	1954 - 55	0.12	1222	1223.2	1238.2	30.0	1245.0	14,600
Cassara	1976 - 77	0.21	1271.5	1271.5	1291.7	66.0	1295.4	36,700
Chamberlain	1974 - 75	0.04	1084.6	1084.0	1097.5	20.0	1101.3	4,700
Childs	1963 - 64	0.30	1022	1022.0	1058.8	23.0	1071.0	50,400
Cloud Creek	1972 - 73	0.01	2350.5	2350.5	2360.0	(5)	2362.0	5,100
Cloudcroft	1973 - 74	0.21	313.9	315.0	329.5	36.0	329.5	34,700
Cooks	1951 - 52	0.58	2058	2058.0	2082.9	48.0	2092.0	51,900
Cooks M-1A	1975 - 76	(13)	2120.0	(10)	2142.4	(10)	(10)	33,700
Crestview	1983 - 84	0.03	864.4	864.0	886.2	20.0	891.7	5,900 (16)
Crocker	1983 - 84	0.67	1064.2	1064.2	1069.8	36.0	1077.0	19,300 (16)
Deer	1954 - 55	0.59	1185.4	1185.0	1201.0	56.0	1209.8	56,600
Denivelle	1976 - 77	0.18	1471	1471.0	1479.3	46.0	1483.3	8,200
Devonwood	1981 - 82	0.03	1899	1899.0	1915.8	22.0	1921.5	5,700
Dry Canyon-South Fork	1978 - 79	1.05	1062.8	1062.5	1074.8	32.0	1079.3	7,900
Dunsmuir	1935 - 36	0.84	2228	2227.7	2257.2	60.0	2272.2	102,700
Eagle	1936 - 37	0.48	1848.3	1848.3	1880.2	60.0	1895.2	62,400
Elmwood	1964 - 65	0.31	912	911.5	938.0	22.0	952.0	66,400
Emerald-East	1964 - 65	0.32	1185.1	1181.1	1192.0	30.0	1204.0	13,600
Englewild	1961 - 62	0.44	1274.9	1275.0	1297.0	50.0	1300.0	40,600
Fair Oaks	1935 - 36	0.21	1544	1544.0	1561.9	(6)	1566.5	23,800
Fern	1935 - 36	0.31	1438.7	1462.4 (1)	1470.2	25.0	1480.5	30,600
Fieldbrook	1974 - 75	0.35	712.7	713.0	718.0	28.0	722.3	2,800
Golf Club Drive	1970 - 71	0.32	880.7	880.7	902.0	36.7	915.0	14,700
Gordon	1973 - 74	0.18	1075.7	1075.0	1088.0	22.0	1096.0	16,800

LOS ANGELES COUNTY DEPARTMENT OF PUBLIC WORKS

DATA SHEET A

DEBRIS BASIN - DESIGN DATA

Including 1992-1993 Storm Season

Compiled by: Hydraulic and Water Conservation
Division - Sedimentation Management
Date: November 30, 1993
FILE: DSA93.WK3

DEBRIS BASIN	FIRST DEBRIS SEASON	UNCONTROLLED DRAINAGE AREA ABOVE BASIN (SQ. MI.)	BOTTOM ELEV. AT MAX. CAP. (FT.)	ELEV. PORT INVERT (FT.)	ELEV. SPILLWAY CREST (FT.)	WIDTH SPILLWAY (FT.)	ELEV. CREST. OF DAM (FT.)	MAX. DEB. CAP. (CU. YDS.)
Gould	1947 - 48	0.36	1529.5	1528.2	1548.0	55.0	1548.0	52,800
Gould (Upper)	1976 - 77	0.18	1863.9	1863.9	1897.7	32.0	1901.0	52,300
Halls	1935 - 36	0.86	1641.6	1641.8	1661.3	131.0	1664.0	89,400
Harrow	1958 - 59	0.43	1254.8	1255.0	1269.0	40.0	1277.8	68,000
Haven Way	1991 - 92	0.13	1323	1323.0	1329.0	20.0	1335.6	38,200 (14)
Hay	1936 - 37	0.20	1875.4	1901.0	1905.0	36.0	1915.0	34,400
Hillcrest	1962 - 63	0.35	863.5	863.5	885.0	18.0	901.0	57,800
Hog	1969 - 70	0.33	1520.1	1520.0	1535.0	32.0	1547.0	39,600
Hook East	1968 - 69	0.18	1197.5	1198.0	1210.9	37.0	1215.0	22,300
Hook West	1970 - 71	0.17	1144.8	1145.0	1158.9	40.0	1167.0	21,600
Inverness	1982 - 83	0.03	1253	1252.9	1256.7	20.0	1261.0	3,300
Irving Drive	1974 - 75	0.03	905.8	905.0	915.3	12.0	920.0	1,200
Kinneloa	1964 - 65	0.20	1370	1370.0	1388.0	40.0	1395.0	14,100
Kinneloa - West	1966 - 67	0.19	1384.9	1385.0	1400.0	22.0	1408.5	14,200
Lannan	1954 - 55	0.25	1016.0	1015.0	1035.8	14.0	1043.0	41,400 (14)
La Tuna	1955 - 56	5.34	1109.0	1110.0	1140.0	75.0	1157.0	495,300 (14)
Las Flores	1935 - 36	0.45	1685.1	(9)	1715.6	50.0	1726.4	55,600
Las Lomas	1983 - 84	0.07	895.4	896.0	906.6	24.0	911.0	5,400
Limekiln	1963 - 64	3.72	992.0	992.0	1003.0	77.0	1019.0	171,600
Lincoln	1935 - 36	0.50	1275.8	1276.0	1304.0	56.0	1322.5	38,400
Linda Vista	1970 - 71	0.37	979.5	979.5	989.8	40.0	995.7	3,200
Little Dalton	1959 - 60	3.31	1140.0	1139.5	1186.0	84.0	1200.2	660,500
Maddock	1954 - 55	0.26	888.6	891.8	901.0	36.0	904.0	45,000
Marston/Paragon	1988 - 89	0.20	1455.6	1455.6	1460.0	20.0	1466.0	6,000
May No. 1	1953 - 54	0.70	1666.0	1666.0	1684.0	60.0	1692.5	63,200
May No. 2	1953 - 54	0.09	1663.4	1663.5 (2)	1669.5	20.0	1674.0	13,600 (14)
Monument	1981 - 82	0.11	943.8	942.3	950.0	12.0	954.0	6,800
Morgan	1964 - 65	0.60	1135.0	1135.0	1158.0	45.0	1167.0	47,700
Mountbatten	1983 - 84	0.01	1136.2	1135.5	1140.9	20.0	1141.0	1,400
Mull	1973 - 74	0.15	1146.9	1147.0	1154.0	20.0	1165.0	12,500
Mullally (11)	1974 - 75	0.34	2420.0	2420.0	2435.4	42.0	2439.6	9,400
Nichols	1937 - 38	0.35	480.5	481.0	485.1	50.0	495.0	14,100
Oak	1975 - 76	0.05	2145.4	2145.7	2151.8	50.0	2156.2	8,700
Oakglade	1974 - 75	0.06	1274.6	1280.0	1290.0	20.0	1296.0	7,250
Oakmont View Drive	1984 - 85	0.02	1315.5	1315.5	1327.5	20.0	1327.5	3,400
Oliver	1989 - 90	0.18	1258.0	1258.0	1278.3	41.0	1283.3	32,100
Pickens	1935 - 36	1.50	1563.6	1564.0	1600.0	123.0	1613.0	125,100
Pinelawn	1973 - 74	0.02	2431.0	2430.5	2443.0	(7)	2448.5	3,200
Rowley	1953 - 54	0.21	1703.6	1703.6	1714.0	60.0	1722.0	43,100
Rowley (Upper)	1976 - 77	0.31	1926.0	1926.0	1946.0	42.0	1951.3	28,800

LOS ANGELES COUNTY DEPARTMENT OF PUBLIC WORKS

DATA SHEET A

DEBRIS BASIN - DESIGN DATA

Including 1992-1993 Storm Season

Compiled by: Hydraulic and Water Conservation
Division - Sedimentation Management
Date: November 30, 1993
FILE: DSA93.WK3

DEBRIS BASIN	FIRST DEBRIS SEASON	UNCONTROLLED DRAINAGE AREA ABOVE BASIN (SQ. MI.)	BOTTOM ELEV. AT MAX CAP. (FT.)	ELEV PORT INVERT (FT.)	ELEV. SPILLWAY CREST (FT.)	WIDTH SPILLWAY (FT.)	ELEV. CREST. OF DAM (FT.)	MAX. DEB. CAP. (CU. YDS.)
Rubio	1943 - 44	1.26	1582.1	1582.1	1608.3	59.0	1625.5	127,200
Ruby (Lower)	1955 - 56	0.28	810.8	809.6	828.0	45.0	833.0	28,600
Rye	1981 - 82	1.11	1073.9	1073.8	1077.7	58.2	1081.5	19,100
Saddleback	1988 - 89	0.04	1779.0	1779.3	1790.0	(10)	1796.0	27,000
Santa Anita	1959 - 60	1.70	748.5	748.5 (3)	774.7	160.0	796.0	394,600
Sawpit	1954 - 55	2.82	930.3	930.3	982.0	110.0	1000.0	635,700
Scholl	1945 - 46	0.16	950.0	950.0 (2)	956.0	76.0	966.0	9,300
Schoolhouse	1962 - 63	0.28	1459.6	1460.0	1478.5	20.0	1491.0	67,700
Schwartz	1976 - 77	0.25	1294.7	1294.7	1313.2	35.0	1319.0	45,400
Shields	1937 - 38	0.06	2030.0	2050.0	2058.1	30.0	2070.2	34,800
Sierra Madre Dam (12)	1927 - 28	2.39	1119.6	1119.5	1172.5	62.5	1175.0	136,400
Sierra Madre Ville	1957 - 58	1.46	1069.2	1069.2	1088.9	48.0	1102.5	402,300
Snover	1936 - 37	0.21	1862.8	1862.7	1879.0	40.0	1893.7	24,800
Sombrero	1969 - 70	1.06	1539.6	1540.0	1564.8	45.0	1580.0	87,900
Spinks	1958 - 59	0.42	750.0	750.0	761.5	40.0	765.9	56,000
Starfall	1973 - 74	0.13	2428.0	2428.0	2441.5	30.0	2446.5	14,900
Stetson	1969 - 70	0.29	1556.0	1555.0	1570.0	32.0	1570.0	41,300
Stough	1940 - 41	1.65	1006.0	1005.8	1031.5 (4)	100.0	1043.5	180,600
Sturtevant	1967 - 68	0.03	975.0	971.0	983.8	8.0	990.0	1,400
Sullivan	1970 - 71	2.38	570.0	570.0	587.0	50.0	599.3	51,000
Sunnyside	1970 - 71	0.02	1290.0	1290.0	1299.5	15.0	1303.8	3,400
Sunset Canyon-Deer	1982 - 83	0.21	1382.4	1380.5	1401.8	24.0	1409.1	5,000
Sunset (Lower)	1963 - 64	0.45	1003.8	994.5	1040.0	40.0	1056.0	158,900 (14)
Sunset (Upper)	1928 - 29	0.44	1574.2	1574.0	1603.7	75.0	1610.1	15,900
Turnbull	1952 - 53	0.99	476.1	475.6	492.0	40.0	503.0	21,600
Upper Shields (15)	1976 - 77	0.21	2498.0	2498.0	2530.0	33.3	2536.0	35,400 (14)
Verdugo	1935 - 36	9.40	1109.5	1110.0	1119.7	145.0	1131.0	131,000
Ward	1956 - 57	0.12	2021.8	2022.0	2043.0	58.0	2035.3	26,400
West Ravine	1935 - 36	0.25	1468.8	1469.6 (1)	1501.9	20.0	1505.5	44,900
Westridge	1974 - 75	0.02	894	894.0	901.0	10.7	906.0	1,400
Wildwood	1967 - 68	0.65	1342.9	1342.9	1354.0	50.0	1360.0	20,700
William S. Hart Park	1983 - 84	0.09	1282.5	1280.0	1290.0	19.0	1293.0	2,400
Wilson	1962 - 63	2.58	1493.0	1493.0	1526.0	60.0	1543.0	313,100
Winery	1968 - 69	0.18	1920	1920.0	1935.0	20.0	1945.0	29,200
Zachau	1956 - 57	0.35	1803.4	1803.1	1820.5	44.0	1823.0	47,900 (14)

114 DEBRIS BASINS

74

7,608,450

DATA SHEET A

DEBRIS BASIN - DESIGN DATA

Including 1992-1993 Storm Season

Compiled by: Hydraulic and Water Conservation
Division - Sedimentation Management
Date: November 30, 1993
FILE:DSAR93.WK3

- (1) LOWEST CLEAR WATER OUTLET, NOT SPILLWAY.
- (2) ELEVATION OF SPILLWAY NOTCH.
- (3) FLOW LINE OF SLUICeway.
- (4) ELEVATION OF SPILLWAY INTO OUTLET CHANNEL. ELEVATION OF OVERFLOW SPILLWAY 1036.9 FEET.
- (5) ONE 30-INCH REINFORCED CONCRETE PIPE.
- (6) FOUR 36-INCH CORRUGATED METAL PIPES.
- (7) ONE 36-INCH REINFORCED CONCRETE PIPE. (ELEVATED INLET)
- (8) DEBRIS CAPACITY AVAILABLE WITHIN RIGHT OF WAY LIMITS.
- (9) PIT-TYPE BASIN.
- (10) INFORMATION UNAVAILABLE.
- (11) SPECIAL CLEANOUT REQUIRED DUE TO LIMITED STORAGE.
- (12) CLEANOUT REQUIRED WHEN DEBRIS REACHES OR EXCEEDS ELEV. 1128.9 AGAINST FACE OF DAM.
- (13) VALUES ARE COMBINED WITH COOKS DEBRIS BASIN
- (14) VALUES ARE BASED ON RECENTLY APPROVED CUT PLANS OR NEW MAX. CAPACITY
- (15) NEW DEBRIS BASIN REPLACING THE OLD BASIN IMMEDIATELY UPSTREAM.
- (16) SPILLWAY LEVEL STORAGE CAPACITY.

LOS ANGELES COUNTY DEPARTMENT OF PUBLIC WORKS

DATA SHEET B

DEBRIS BASIN-DEBRIS PRODUCTION HISTORY

Including 1992 - 1993 Storm Season

Compiled by: Hydraulic and Water Conservation
Division - Sedimentation Management
Date: November 30, 1993
FILE: DSB93.WK3

DEBRIS BASIN	NUMBER OF SEASONS	TOTAL DEBRIS DEPOSITED (CU. YDS.) (1)	MAXIMUM SEASONAL DEBRIS PRODUCTION		ESTIMATED CONDITIONS		
			(CU. YDS.)	SEASON	DEBRIS STORED (CU. YDS.)	CAPACITY AVAILABLE (CU. YDS.)	PER CENT
Aliso	(11) 23	171,058	30,700	1982-83	-1000	42,700	102 (5)
Arbor Dell	(11) 22	1,989	800	1979-80	460	11,940	96
Auburn	(11) 39	85,576	20,100	1961-62	0 (18)	31,600	100
Bailey	(11) 48	239,854	91,000	1979-80	0 (18)	128,800	100
Beatty	23	14,061	7,800	1979-80	4,000	39,000	91
Bigbriar	22	3,318	623	1987-88	60	2,540	98
Big Dalton	34	859,003	296,700	1968-69	31,200	486,600	94
Blanchard	25	78,368	36,600	1977-78	1,557 (17)	72,943	98
Blue Gum	25	38,366	19,100	1977-78	-2893	42,493	107
Brace	22	40,058	12,000	1977-78	300	27,200	99
Bracemar	22	871 (7)	283	1980-81	-193	893	128 (9)
Bradbury	39	268,864	70,200	1968-69	2,700	87,100	97
Brand	58	274,764	53,100	1977-78	4,452 (17)	161,548	97
Buena Vista	8	440	40	1987-88	440	20,960	98
Carriage House (11)	23	4,742	3,400	1979-80	200	5,900	97
Carter	(11) 39	37,596	12,600	1979-80	0 (18)	14,600	100
Cassara	17	29,487	16,800	1977-78	2,300	34,400	94
Chamberlain	(11) 19	710	300	1974-75	54	4,646	99
Childs	30	46,518	10,700	1980-81	1,500	48,900	97
Cloud Creek	21	3,362	1,800	1977-78	-570	5,670	111
Cloudcroft	20	12,372	6,100	1973-74	1,450	33,250	96
Cooks	42	175,621 (3)	61,200 (3)	1977-78	2,600 (3)	83,000 (3)	97 (3)
Cooks M-1A	18	(13)	(13)	(13)	(13)	(13)	(13)
Crestview	10	(6)	(6)	(6)	10	5,890	100
Crocker	10	8,452	5745	1991-92	2,336 (17)	16,964	88
Deer	39	168,108	44,200	1968-69	6,000	50,600	89
Denivelle	17	9,677	5,500	1977-78	400	7,800	95
Devonwood	(11) 12	766	400	1991-92	0	5,700	100
Dry Canyon-South Fork	15	8,698	5,300	1979-80	750	7,150	91
Dunsmuir	58	370,928	86,200	1977-78	6,000	96,700	94
Eagle	57	194,940	41,700	1937-38	5,477	56,923	91
Elmwood	(11) 29	53,711	16,100	1980-81	300	66,100	100
Emerald-East	(11) 29	10,561	1,800	1985-86	45	13,555	100
Englewild	32	86,770 (2)	60,200 (2)	1968-69	1,700	38,900	96
Fair Oaks	(11) 58	111,482	15,700	1935-36	0	23,800	100
Fern	(11) 58	165,699	23,900	1968-69	0 (18)	30,600	100
Fieldbrook	19	1,894	500	1991-92	409 (17)	2,391	85
Golf Club Drive	23	33,400	11,600	1979-80	642	14,058	96
Gordon	20	5,604	3,800	1977-78	1,000	15,800	94

LOS ANGELES COUNTY DEPARTMENT OF PUBLIC WORKS

DATA SHEET B

DEBRIS BASIN-DEBRIS PRODUCTION HISTORY

Including 1992 - 1993 Storm Season

Compiled by: Hydraulic and Water Conservation
Division - Sedimentation Management
Date: November 30, 1993
FILE: DSB93.WK3

DEBRIS BASIN	NUMBER OF SEASONS	TOTAL DEBRIS DEPOSITED (CU. YDS.) (1)	MAXIMUM SEASONAL DEBRIS PRODUCTION		ESTIMATED CONDITIONS		
			(CU. YDS.)	SEASON	DEBRIS STORED (CU. YDS.)	CAPACITY AVAILABLE	
						(CU. YDS.)	PER CENT
Gould	46	125,373	18,000	1965-66	4,500	48,300	91
Gould (Upper)	17	37,013	11,177	1991-92	1,500	50,800	97
Halls	58	603,710	102,100	1937-38	4,500	84,900	95
Harrow	35	78,347 (2)	63,400 (2)	1968-69	-5511	73,511	108
Haven Way	2	(8)	(8)	(8)	0	38,200	100
Hay	57	72,563	18,200	1937-38	5,349	29,051	84
Hillcrest	31	52,649	11,700	1964-65	4,762	53,038	92
Hog	24	7,034	3,900	1977-78	600	39,000	98
Hook East	25	46,609 (2)	40,200 (2)	1968-69	900	21,400	96
Hook West	23	7,188	3,600	1979-80	350	21,250	98
Inverness	11	316	252	1982-83	518	2,782	84
Irving Drive	19	1,746	600	1980-81	200	1,000	83
Kinneloa (11)	29	56,950 (2)	17,600 (2)	1968-69	0 (18)	14,100	100
Kinneloa West (11)	27	73,122 (2)	22,200 (2)	1968-69	0 (18)	14,200	100
Lannan	39	84,767	18,200	1969-70	700	40,700	98
La Tuna	38	652,523	172,100	1977-78	59,164	436,137	88
Las Flores (11)	58	223,452	36,000	1937-38	0 (18)	55,600	100
Las Lomas	10	615	(6)	(6)	650	4,750	88
Limekiln	30	308,861	42,300	1965-66	3,813	167,987	98
Lincoln (11)	58	134,889	28,400	1968-69	1,028 (17)	37,372	97
Linda Vista	23	13,257	3,400	1977-78	-58 (17)	3,258	102
Little Dalton	34	933,473	337,800	1968-69	44,340	616,160	93
Maddock	39	57,134	16,200	1980-81	2,200	42,800	95
Marston/Paragon	5	130	(8)	(8)	130	5,870	98
May No. 1 (11)	40	225,560	45,800	1968-69	-292 (17)	63,492	99
May No. 2	40	28,639	6,200	1966-67	657	9,343	93
Monument	12	3,009	2,600	1981-82	292	6,508	96
Morgan	29	30,841	12,900	1968-69	1,200	46,500	97
Mountbatten	10	110	(6)	(6)	110	1,290	92
Mull	20	2,394	1,100	1979-80	500	12,000	96
Mullally (10)	19	65,074 (4)	24,400 (4)	1977-78	691 (17)	8,709	93
Nichols	56	128,380	21,800	1951-52	516	13,584	96
Oak	18	13,267	6,900	1977-78	0	8,700 (18)	100 (18)
Oakglade	19	1,567	1,200	1977-78	650	6,600	91
Oakmont View Drive	9	440	221	1991-92	-126 (17)	3,526	104
Oliver	4	31,180 (14)	16255 (14)	1977-78	800	31,300	98
Pickens	58	730,027	140,600	1977-78	920	124,180	99
Pinelawn	20	5,309	1,200	1976-77	130	3,070	96
Rowley	40	78,235 (4)	13,000 (4)	1977-78	2,000	41,100	95
Rowley (Upper)	17	51,805 (4)	31,900 (4)	1977-78	-574	29,374	102

LOS ANGELES COUNTY DEPARTMENT OF PUBLIC WORKS

DATA SHEET B

DEBRIS BASIN-DEBRIS PRODUCTION HISTORY

Including 1992 - 1993 Storm Season

Compiled by: Hydraulic and Water Conservation
Division - Sedimentation Management
Date: November 30, 1993
FILE: DSB93.WK3

DEBRIS BASIN	NUMBER OF SEASONS	TOTAL DEBRIS DEPOSITED (CU. YDS.) (1)	MAXIMUM SEASONAL DEBRIS PRODUCTION		ESTIMATED CONDITIONS		
			(CU. YDS.)	SEASON	DEBRIS STORED (CU. YDS.)	CAPACITY AVAILABLE (CU. YDS.)	PER CENT
Rubio (11)	50	287,048	133,000	1979-80	0 (18)	127,200	100
Ruby (Lower)	38	21,432	8,300	1968-69	2,000	26,800	93
Rye	12	15,748	10,000	1981-82	-756 (17)	19,856	104
Saddleback	5	520	(6)	(6)	520	26,480	98
Santa Anita	34	755,383 (2,3)	132,000 (2,3)	1961-62	-3334	397,934	101
Sawpit	39	707,247 (2,3)	232,200 (2,3)	1968-69	20,250	615,450	97
Scholl	48	18,294	800	1968-69	800 (19)	8,500	91
Schoolhouse	31	34,341	21,600	1962-63	5,086	62,614	92
Schwartz	17	49,359	21,600	1977-78	4,300	41,100	91
Shields	56	173,622 (3)	7,800	1937-38	1,810	32,990	95
Sierra Madre Dam (12)	66	366,388 (2)	95,200 (2)	1968-69	1,515	134,885	99
Sierra Madre Villa (11)	36	547,980	118,600	1961-62	605	401,895	100
Snover	57	109,480	19,300	1938-39	5,083	19,717	80
Sombrero	24	11,555	3,300	1977-78	5,700	82,200	94
Spinks	35	67,486	15,600	1968-69	1,100	54,900	98
Starfall	20	29,110	14,200	1977-78	1,937	12,963	87
Stetson (11)	24	21,114	1,500	1977-78	1,927 (17)	39,373	95
Stough	53	162,819	44,100	1964-65	3,500	177,100	98
Sturtevant	26	1,356	500	1977-78	155	1,245	89
Sullivan	23	93,952	35,300	1979-80	0	51,000	100
Sunnyside (11)	23	1,829	800	1978-79	100	3,300	97
Sunset Canyon-Deer	11	4,155	3,400	1982-83	180	4,820	96
Sunset (Lower)	30	145,469	20,200	1980-81	3,700	155,200	98
Sunset (Upper)	65	149,680	27,000	1964-65	-1470 (17)	17,370	109
Turnbull (11)	41	69,144 (2)	15,900 (2)	1968-69	-342 (17)	21,942	102 (5)
Upper Shields (15)	17	43,217 (4,14)	16,900 (4,14)	1977-78	0	35,400	100
Verdugo	58	827,992	105,400	1937-38	13,334	117,666	90
Ward	37	52,671	17,800	1977-78	1,233	25,167	95
West Ravine (11)	58	149,623	29,900	1937-38	0 (18)	44,900	100
Westridge	19	223	(6)	(6)	210	1,190	85
Wildwood	26	86,252	16,700	1977-78	-1836 (17)	22,536	109
William S. Hart Park	10	658	600	1983-84	-97	2,497	104
Wilson	31	215,634	55,500	1968-69	14,671	298,429	95
Winery	25	27,215	9,400	1968-69	0	29,200	100
Zachau	37	110,636 (4)	48,100 (4)	1977-78	3,496	44,404	93

114 DEBRIS BASINS

13,943,478

7,308,879

DEBRIS BASIN-DEBRIS PRODUCTION HISTORY

Including 1992 - 1993 Storm Season

DATA SHEET B

Compiled by: Hydraulic and Water Conservation
Division - Sedimentation Management
Date: November 30, 1993
FILE: DSB92.WK4.

- (1) VOLUME OF DEBRIS DEPOSITED IN BASINS DOES NOT INCLUDE DEBRIS SLUICED THROUGH OPEN PORTS OR NOTCH.
- (2) VOLUME OF DEBRIS DEPOSITED DOES NOT INCLUDE DEBRIS WHICH PASSED OVER SPILLWAY DURING THE STORMS IN 1968-69 SEASON.
- (3) INCLUDING DEBRIS FROM UPSTREAM BASIN OR DAM.
- (4) VOLUME OF DEBRIS DEPOSITED DOES NOT INCLUDE DEBRIS WHICH PASSED OVER SPILLWAY DURING THE STORMS IN 1977-78 SEASON.
- (5) DEBRIS CAPACITY AVAILABLE WITHIN RIGHT OF WAY LIMITS.
- (6) NO SIGNIFICANT DEBRIS INFLOWS RECORDED.
- (7) NO DEBRIS RECORDS EXIST FOR THE FIRST 9 SEASONS.
- (8) INFORMATION UNAVAILABLE.
- (9) MAXIMUM CAPACITY MAY BE MORE THAN SHOWN AND WILL BE REVIEWED.
- (10) SPECIAL CLEANOUT REQUIRED DUE TO LIMITED STORAGE
- (11) SPECIAL CLEANOUT REQUIRED DUE TO BURNED WATERSHED
- (12) CLEANOUT REQUIRED WHEN DEBRIS REACHES OR EXCEEDS ELEV. 1128.9 AGAINST FACE OF DAM.
- (13) VALUES ARE COMBINED WITH COOKS DEBRIS BASIN.
- (14) INCLUDING DEBRIS DATA FROM PREVIOUS BASIN.
- (15) NEW DEBRIS BASIN REPLACING THE OLD BASIN IMMEDIATELY UPSTREAM.
- (16) BASED ON DESIGN DRAWING USED FOR ENLARGING THE BASIN CAPACITY. THE DATA WILL BE REVISED BASED ON UPDATED TOPO MAP.
- (17) DEBRIS IN STORAGE HAS BEEN CALCULATED BASED ON POST CLEANOUT SURVEY.
(DEBRIS IN STORAGE FOR OTHER BASINS ARE BASED ON FIELD ESTIMATES.)
- (18) THE BASIN HAS BEEN CLEANED OUT FOLLOWING THE KINNELOA FIRE OF OCT. 27, 1993.

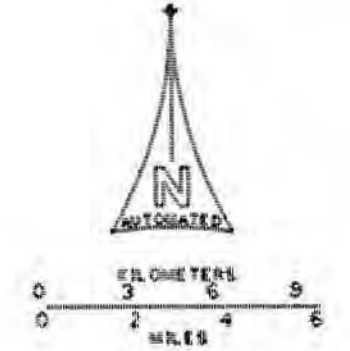
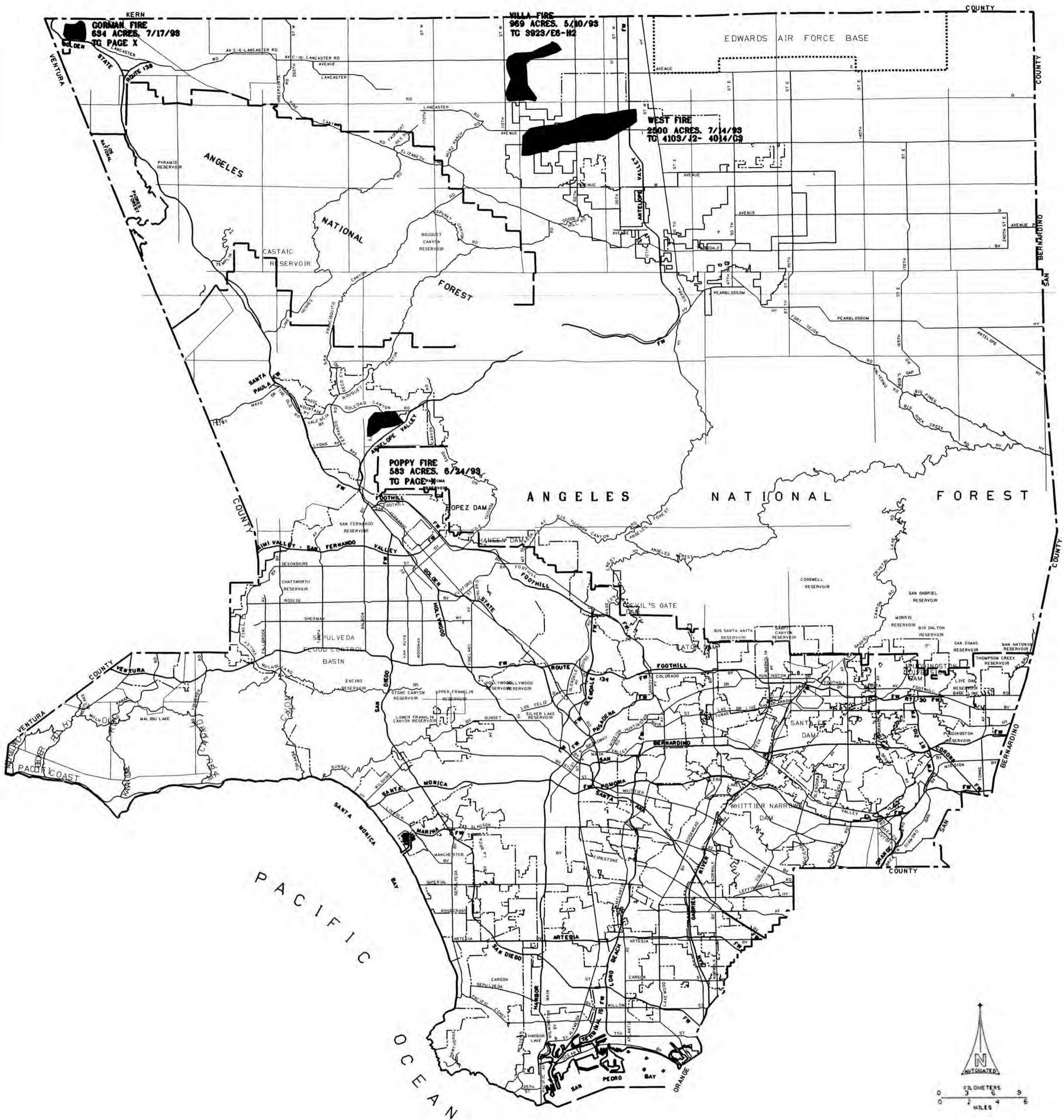

MAP OF
COUNTY OF LOS ANGELES

DEPARTMENT OF PUBLIC WORKS

OCT. 1, 1992 THRU
SEPT. 30, 1993 FIRES
OVER 500 ACRES IN AREA
BURNED AREA LOCATIONS

WATER QUALITY

WATER QUALITY

Since its conception, the Flood Control District (now Department of Public Works) has actively engaged in operations which have proven indispensable in preserving the integrity of our water resources, both quantity and quality, and has aided in the establishment of regulations or controlling criteria by those agencies so empowered.

Prior to March 1986, monitoring activities in the field of water quality control were conducted by the Water Quality Section of Hydraulic/Water Conservation Division. In March 1986, the responsibilities of conducting such activities were transferred to Waste Management Division as a result of the consolidation. These activities include, among others, the collection of water quality samples, their analyses, and the interpretation and reporting of the resulting data.

Areas of involvement include the monitoring of all groundwater basins through the sampling of numerous wells, the monitoring of storm and low water flows at various strategic locations on the major streams or channels, and an assumed or obligated responsibility to monitor the quality effects and subsurface travel of recharge areas, specifically the Whittier Narrows Spreading Grounds area.

The Water Quality Section, together with personnel of other Departmental divisions, also conducts investigations into pollution problems relative to our facilities, particularly those from industrial discharges, vehicle accidents, ruptured pipelines, or the indiscriminate dumping of various waste products.

The principal objectives of these investigations are to determine the degree and apparent source or origin of the pollution and to take the necessary action that will immediately abate the existing problem and possibly provide a means to prevent or limit recurrence.

Since 1986, the Water Quality Section also has been conducting the screening of proposed connections to County storm drains, and developments over County right-of-ways, for the purpose of minimizing/eliminating potential of pollutants to the storm drain waters and, thereby, to the environment.

The above-mentioned activities of the Water Quality Section have recently been expanded, particularly in the areas of interfacing and coordinating with other municipalities/cities, environmental organizations, as well as Federal and State agencies. In compliance with mandates under the 1987 Clean Water Act, the Department is implementing tasks required by the National Pollutant Discharge Elimination System (NPDES) municipal stormwater permit.

The NPDES Permit (CA0061654) issued for the storm drain system in Los Angeles County requires the development and implementation of programs to improve the quality of stormwater/urban runoff discharges into the storm drain system. Los Angeles County, represented by the Department of Public Works, is the Principal Permittee and the cities within the County are Co-Permittees. The drainage area covered by the Permit is divided

into three phases; with Phase I, the Santa Monica Bay Drainage Basin, having begun July 1, 1990, Phase II, which involves the Upper L.A. River and Upper San Gabriel River Drainage Basins, having begun in July 1992, and Phase III, which includes the Lower L.A. River, Lower San Gabriel River, and Santa Clarita River Drainage Basins, initiated in July 1993.

The Permit requires the County, together with the cities to develop and implement a stormwater/urban runoff monitoring program to gather data on the type and source of pollutants within the drainage basins. The permit also requires the development and implementation of Best Management Practices (BMPs) to reduced the amount of pollutants that find their way into the storm drain system and to implement procedures to detect and eliminate illegal discharges.

SURFACE WATER QUALITY

Prior to 1984, dry weather samples were collected from 30 sampling stations on a monthly basis for analysis such as general minerals, bacteria, pesticides, and heavy metals. In addition, storm samples were also collected and analyzed at least three times annually from the same 30 stations during storms season.

From 1984 to 1987, as a result of reorganization, the number of surface water monitoring stations was reduced to 21, while the parameters analyzed were reduced to include only total dissolved solids, pH, and dissolved oxygen. Storm sampling activities were also significantly curtailed.

In 1988, recognizing the inadequacy of the then existing monitoring program to meet the Department's need in dealing with the important issues in the areas of water quality, the Department Administration approved and implemented an expanded monitoring program effective May 1, 1988.

There are 28 monitoring stations in the Department's current Surface Water Quality Monitoring Program, from which dry grab weather samples are collected and analyzed on a monthly basis. These sampling stations are strategically located throughout the Department's major storm drains and water conservation facilities where the flows are representative of typical land uses as well as areas of significant water quality concerns. Of the 28 monitoring stations in the program, six are located at the outlets to Santa Monica Bay, while one is located in the mountain area where flow is considered to be natural and uncontaminated with the various pollutants associated with urbanization and developed land uses.

Monthly dry weather grab samples, thus collected, are analyzed for general minerals (pH, specific conductance, total dissolved solids, total hardness, potassium sulfate, calcium, magnesium, chloride, fluoride, nitrate-nitrogen, nitrite-nitrogen, ammonium-nitrogen, phosphate-P, boron, iron, and manganese), bacteria, pesticides, heavy metals (silver arsenic, barium, cadmium, chromium, mercury, lead, selenium, copper, nickel, zinc, and chromium [VI]), oil and grease, total organic carbon, total petroleum hydrocarbons, PCB's, biochemical

oxygen demand, and volatile organic compounds (TCE, carbon tetrachloride, vinyl chloride, 1,2 dichlorethene, benzene, 1,1 dichloroethylene, 1,1,1 trichloroethane, p-dichlorobenzene). In addition, storm samples (also grab) are collected for three to four storms annually from 21 stations, including San Gabriel Coastal and Rio Hondo Spreading Grounds for extensive analysis similar to those for dry weather samples, with additional testing of total suspended solids and volatile suspended solids to be included. For storm samples collected at San Gabriel Coastal and Rio Hondo Spreading Grounds, priority pollutant constituents are also analyzed under an agreement with the Central and West Basin Water Replenishment District.

A selective list of total dissolved solids is shown for some of the sampling locations on the streams and channels monitored under the Surface Water Quality Program. For a conception of the analysis performed on the surface flows, a yearly compilation of constituent determination is shown for one (Los Angeles River at Wardlow) of the sampling stations in the program.

Beginning in early 1994, in response to the Stormwater Permit Requirements, a more intensive monitoring program will be initiated. This program will utilize automated samplers to collect flow-composite samples to better characterize sampled events. The automated samplers will be installed in the Santa Monica Bay Drainage Basin first, with the other basins following in succeeding years.

GROUNDWATER QUALITY

The annual sampling of water wells, under a selected scheduling, in five major basins in Los Angeles County comprise the Groundwater Quality Program. The program, initiated in 1970, is coordinated with the State of California Department of Water Resources and the City of Los Angeles Department of Water and Power. These agencies participate in the obtainment and analysis of samples.

All the water well samples are from active production wells used either for municipal supply, irrigation, or for industrial purposes and are selected to represent a general portrayal of basin water quality conditions. The samples taken under this program are analyzed for major minerals, total dissolved solids, electrical conductivity, pH, and in specific cases, phosphate, iron, manganese, fluoride, or boron.

WATER QUALITY DATA ACCESSIBILITY

Data acquired from the various programs are on file in the Water Quality Section. In addition, all data is accessible to any user through STORET, an Environmental Protection Agency computer system that stores, retrieves, and manipulates data using agency code 21CALAFD.

Surface Water Quality Monitoring Selected Surface Stations

**Table I Total Dissolved Solids – ppm
1992–93 Season (Dry Weather Flow)**

Sampling Locations	Oct. 1992	Nov. 1992	Dec. 1992	Jan. 1993	Feb. 1993	Mar. 1993	Apr. 1993	May 1993	Jun. 1993	Jul. 1993	Aug. 1993	Sep. 1993	Average
Ballona Creek at Sawtelle Blvd.	772	720	682	672	900	900	850	684	780	734	720	724	762
Coyote Creek at Orangethorpe Avenue Willow Street	938 808	976 840	1096 756	1300 1200	– –	1200 1100	1272 924	1200 924	1566 1010	1194 922	1146 1178	1076 1922	1179 1053
Dominguez Channel Above Vermont Avenue	844	882	*	450	994	*	*	1000	610	–	1310	886	872
Los Angeles River at Wardlow Road Firestone Boulevard	738 728	710 692	584 748	432 444	– –	700 720	926 912	778 820	672 684	– 734	698 452	704 708	694 695
Los Cerritos Channel at Stearns Street	544	584	470	648	–	690	948	930	1064	828	888	592	744
Rio Hondo River at Southern Avenue Spreading Grounds	– 386	– 660	– 642	716 190	– –	550 296	– 326	424 486	– 222	1550 268	766 –	1200 652	868 413
Santa Monica Cyn. Ch. at Short Street	904	768	798	588	650	700	790	788	840	892	850	900	789
San Gabriel River at Spreading Grounds Willow Street	614 838	– 826	624 912	164 204	– –	414 746	686 694	438 758	690 668	676 728	614 –	– 720	547 709
San Jose Creek at Workman Mill Road	838	818	860	994	–	900	982	990	900	924	966	–	917

* = Analysis had been invalidated

Surface Water Quality Analysis
Monthly Monitoring 1992– 93 Season (Dry Weather)
Los Angeles River at Wardlow Road

Constituents ppm	Oct. 1992	Nov. 1992	Dec. 1992	Jan. 1993	Feb. 1993	Mar. 1993	Apr. 1993	May 1993	Jun. 1993	Jul. 1993	Aug. 1993	Sep. 1993	Average
Hardness as CaCO3	296	288	228	248	–	399	464	318	280	–	310	290	312
Calcium	70.5	72.1	57.7	64.1	–	97.7	111.0	83.3	72.1	–	68.1	68.1	76.5
Magnesium	29.2	26.3	20.4	21.4	–	37.6	45.7	26.7	24.3	–	34.0	29.1	29.5
Sodium	117	128	90	40	–	75	120	111	87	–	89	74	93
Potassium	13.4	15.7	11.5	4.7	–	8.9	10.2	11.5	10.0	–	2.4	7.9	9.6
Ammonium	2.6	6.6	6.9	<0.1	–	0.3	1.6	1.1	0.2	–	0.2	2.2	2.2
Alkalinity as CaCO3	163	173	133	133	–	194	204	116	147	–	158	137	156
Sulfate	218	195	154	132	–	258	295	281	228	–	206	215	218
Chloride	168	127	111	44	–	81	143	152	100	–	130	107	116
Flouride	0.36	0.35	0.27	0.29	–	0.36	0.35	0.65	0.52	–	0.49	0.48	0.4
Nitrite–N	<0.03	0.91	1.23	<0.03	–	0.96	<0.03	1.13	0.52	–	1.80	1.31	0.79
Nitrate–N	8.95	6.11	6.59	4.10	–	4.40	4.72	2.15	0.19	–	2.87	4.13	4.42
Phosphate	3.47	3.49	1.87	0.46	–	1.20	1.02	1.94	0.46	–	0.90	0.83	1.56
Total Dissolved Solids	738	710	584	432	–	700	926	778	672	–	698	704	694
BOD	113.4	6.1	15.9	74.0	–	24.9	10.0	NA	18.5	–	49.9	30.9	34.36
Total Organic Carbon	19.2	33.2	34.3	5.2	–	1.5	11.6	NA	16.2	–	13.7	15.0	15.0
Oil & Grease (ppm)	<1	<1	<1	<1	–	<1	<1	<1	<1	–	<1	<1	<1
TPH	<1	<1	<1	<1	–	<1	<1	<1	<1	–	<1	<1	<1
pH	8.5	7.8	8.1	7.1	–	8.0	8.8	8.2	8.1	–	8.7	9.0	8.23
Temperature	58	62	54	56	–	68	70	68	90	–	NA	68	59
MPN/100ml													
Total Coliform	595	>16000	16000	9000	–	16000	16000	2200	40	–	>16000	<16000	
Fecal Coliform	>16000	16000	1300	500	–	500	80	40	<20	–	600	500	
Fecal Streptococcus	1700	3500	130	800	–	300	90	1100	220	–	300	700	884.00
Enterococcus	1300	1700	130	500	–	170	90	500	140	–	110	300	494.00

F5

Surface Water Quality Analysis
Monthly Monitoring 1992-93 Season (Dry Weather)
Los Angeles River at Wardlow Road

Constituents (ppb)	Oct. 1992	Nov. 1992	Dec. 1992	Jan. 1993	Feb. 1993	Mar. 1993	Apr. 1993	May 1993	Jun. 1993	Jul. 1993	Aug. 1993	Sep. 1993	Average
Boron	710	640	610	<250	-	515	805	825	930	-	710	845	
Heavy Metals:													
Arsenic	<10	<10	<10	<10	-	<10	<10	<10	<10	-	<10	10	<10
Barium	<100	<100	<100	<100	-	<100	109	<100	<100	-	<100	139	<100
Cadmium	<10	<10	42	<10	-	<10	<10	100	<10	-	<10	<10	<10
Chromium	<10	<10	<10	<10	-	<10	<10	<10	<10	-	<10	<10	<10
Chromium (6)	<10	<10	<10	<10	-	<10	<10	<10	12	-	<10	<10	<10
Copper	<10	<10	<10	<10	-	<10	<10	<10	<10	-	<10	11	<10
Lead	<10	<10	<10	<10	-	<10	<10	<10	16	-	<10	<10	<10
Mercury	<1	<1	<1	<1	-	<1	<1	<1	<1	-	<1	<1	<1
Nickel	<10	<10	86	<10	-	<10	<10	<10	35	-	<10	<10	<10
Selenium	<5	<5	<5	<5	-	<5	<5	<5	<5	-	<5	<5	<5
Silver	<10	<10	<10	<10	-	<10	<10	<10	<10	-	<10	<10	<10
Zinc	<50	<50	<50	<50	-	<50	<50	<50	<50	-	<50	<50	<50
Iron	<100	<100	260	<100	-	<100	<100	<100	170	-	<100	<100	<100
Manganese	<30	<30	44	<30	-	<30	<30	<30	<30	-	<30	<30	<30
Chlorinated Pesticides:													
Aldrin	<0.05	<0.05	<0.05	<0.05	-	<0.05	<0.05	<0.05	<0.05	-	<0.05	<0.05	<0.05
Lindane	<0.05	<0.05	<0.05	<0.05	-	<0.05	<0.05	<0.05	<0.05	-	<0.05	<0.05	<0.05
a-BHC	<0.05	<0.05	<0.05	<0.05	-	<0.05	<0.05	<0.05	<0.05	-	<0.05	<0.05	<0.05
b-BHC	<0.05	<0.05	<0.05	<0.05	-	<0.05	<0.05	<0.05	<0.05	-	<0.05	<0.05	<0.05
c-BHC	<0.05	<0.05	<0.05	<0.05	-	<0.05	<0.05	<0.05	<0.05	-	<0.05	<0.05	<0.05
Chlordane	<0.05	<0.05	<0.05	<0.05	-	<0.05	<0.05	<0.05	<0.05	-	<0.05	<0.05	<0.05
PP'-DDD	<0.10	<0.10	<0.10	<0.10	-	<0.10	<0.10	<0.10	<0.10	-	<0.10	<0.10	<0.10
PP'-DDDT	<0.10	<0.10	<0.10	<0.10	-	<0.10	<0.10	<0.10	<0.10	-	<0.10	<0.10	<0.10
PP'-DDE	<0.10	<0.10	<0.10	<0.10	-	<0.10	<0.10	<0.10	<0.10	-	<0.10	<0.10	<0.10
Dieldrin	<0.10	<0.10	<0.10	<0.10	-	<0.10	<0.10	<0.10	<0.10	-	<0.10	<0.10	<0.10
Endosulfan I	<0.10	<0.10	<0.10	<0.10	-	<0.10	<0.10	<0.10	<0.10	-	<0.10	<0.10	<0.10
Endosulfan II	<0.10	<0.10	<0.10	<0.10	-	<0.10	<0.10	<0.10	<0.10	-	<0.10	<0.10	<0.10
Endosulfan sulfate	<0.10	<0.10	<0.10	<0.10	-	<0.10	<0.10	<0.10	<0.10	-	<0.10	<0.10	<0.10
Endrin	<0.10	<0.10	<0.10	<0.10	-	<0.10	<0.10	<0.10	<0.10	-	<0.10	<0.10	<0.10
Heptachlor	<0.05	<0.05	<0.05	<0.05	-	<0.05	<0.05	<0.05	<0.05	-	<0.05	<0.05	<0.05
Heptachlor epoxide	<0.05	<0.05	<0.05	<0.05	-	<0.05	<0.05	<0.05	<0.05	-	<0.05	<0.05	<0.05
Toxaphene	<1	<1	<1	<1	-	<1	<1	<1	<1	-	<1	<1	<1

Surface Water Quality Analysis
Monthly Monitoring 1992– 93 Season (Dry Weather)
Los Angeles River at Wardlow Road

Constituents (ppb)	Oct. 1992	Nov. 1992	Dec. 1992	Jan. 1993	Feb. 1993	Mar. 1993	Apr. 1993	May 1993	Jun. 1993	Jul. 1993	Aug. 1993	Sep. 1993	Average
Polychlorinated biphenyls:													
PCB– 1016	<0.50	<0.50	<0.50	<0.50	–	<0.50	<0.50	<0.50	<0.50	–	<0.50	<0.50	<0.50
PCB– 1221	<0.50	<0.50	<0.50	<0.50	–	<0.50	<0.50	<0.50	<0.50	–	<0.50	<0.50	<0.50
PCB– 1232	<0.50	<0.50	<0.50	<0.50	–	<0.50	<0.50	<0.50	<0.50	–	<0.50	<0.50	<0.50
PCB– 1242	<0.50	<0.50	<0.50	<0.50	–	<0.50	<0.50	<0.50	<0.50	–	<0.50	<0.50	<0.50
PCB– 1248	<0.50	<0.50	<0.50	<0.50	–	<0.50	<0.50	<0.50	<0.50	–	<0.50	<0.50	<0.50
PCB– 1254	<0.50	<0.50	<0.50	<0.50	–	<0.50	<0.50	<0.50	<0.50	–	<0.50	<0.50	<0.50
PCB– 1260	<0.50	<0.50	<0.50	<0.50	–	<0.50	<0.50	<0.50	<0.50	–	<0.50	<0.50	<0.50
Volatile Organics:													
Benzene	NA	NA	NA	NA	–	NA	NA	NA	<0.50	–	NA	NA	<0.50
Carbon Tet. Chloride	NA	NA	NA	NA	–	NA	NA	NA	<0.50	–	NA	NA	<0.50
1,2 Dichloroethene	NA	NA	NA	NA	–	NA	NA	NA	<0.50	–	NA	NA	<0.50
1,1 Dichloroethene	NA	NA	NA	NA	–	NA	NA	NA	<0.50	–	NA	NA	<0.50
p–DCB	NA	NA	NA	NA	–	NA	NA	NA	<0.50	–	NA	NA	<0.50
1,1,1 –TCE	NA	NA	NA	NA	–	NA	NA	NA	<0.50	–	NA	NA	<0.50
Trichloroethene	NA	NA	NA	NA	–	NA	NA	NA	<0.50	–	NA	NA	<0.50
Vinyl Chloride	NA	NA	NA	NA	–	NA	NA	NA	<0.50	–	NA	NA	<0.50

PMERT4.5

< = Less than

> = Greater than

NA = Not analyzed

ppm = Parts per million

ppb = Parts per billion

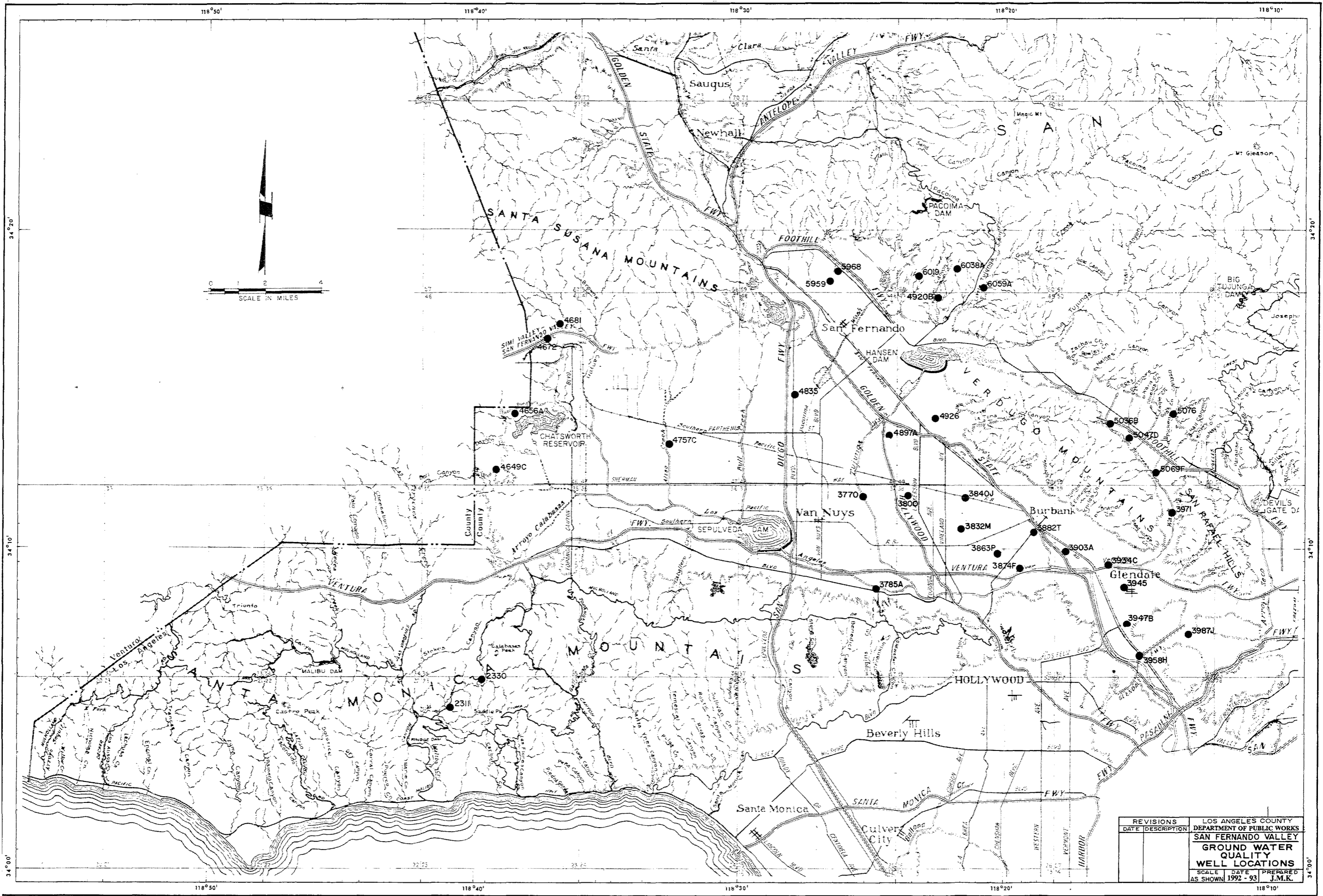

REVISIONS		LOS ANGELES COUNTY DEPARTMENT OF PUBLIC WORKS	
DATE	DESCRIPTION	SAN FERNANDO VALLEY GROUND WATER QUALITY WELL LOCATIONS	
		SCALE 1" = 1 MILE DATE PREPARED AS SHOWN 1992 - 93 J.M.K.	

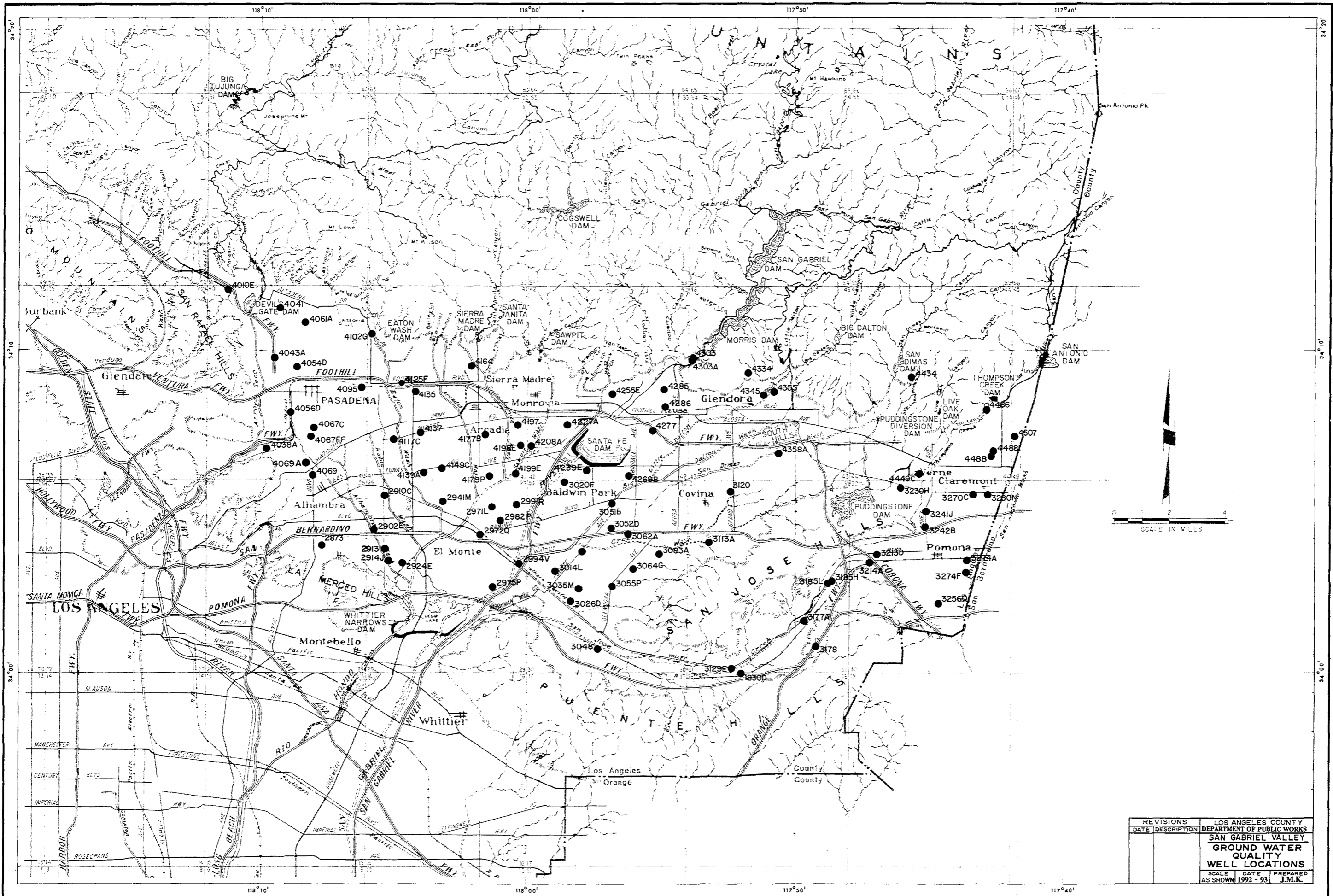

REVISIONS		LOS ANGELES COUNTY DEPARTMENT OF PUBLIC WORKS	
DATE	DESCRIPTION		
		SAN GABRIEL VALLEY GROUND WATER QUALITY WELL LOCATIONS	
SCALE AS SHOWN	DATE PREPARED	1992 - 93 J.M.K.	

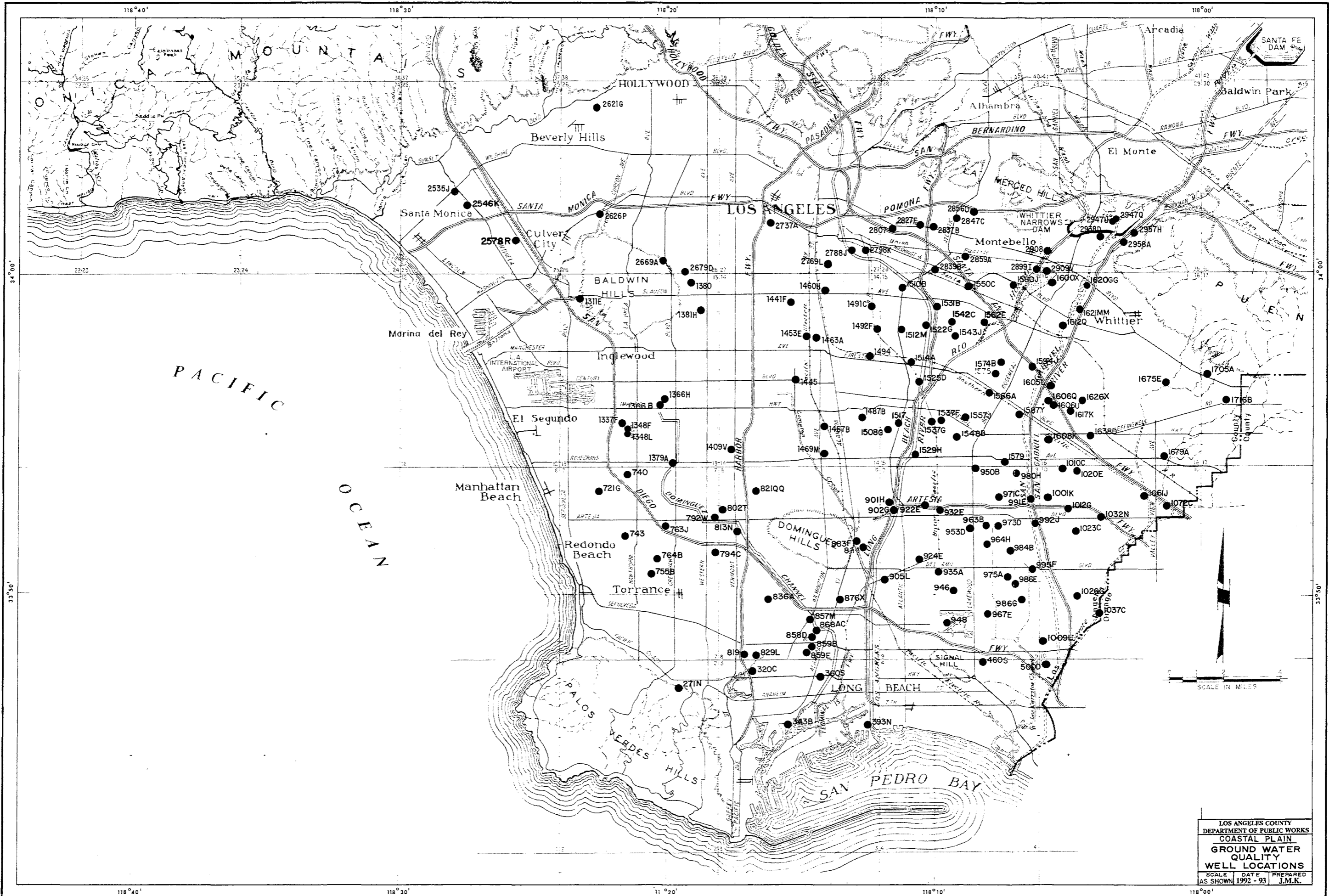

LOS ANGELES COUNTY
 DEPARTMENT OF PUBLIC WORKS
 COASTAL PLAIN
 GROUND WATER
 QUALITY
 WELL LOCATIONS
 SCALE DATE PREPARED
 AS SHOWN 1992 - 93 J.M.K.

C-1

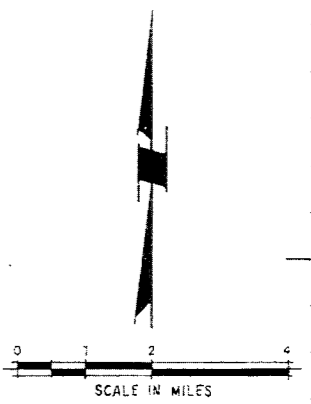
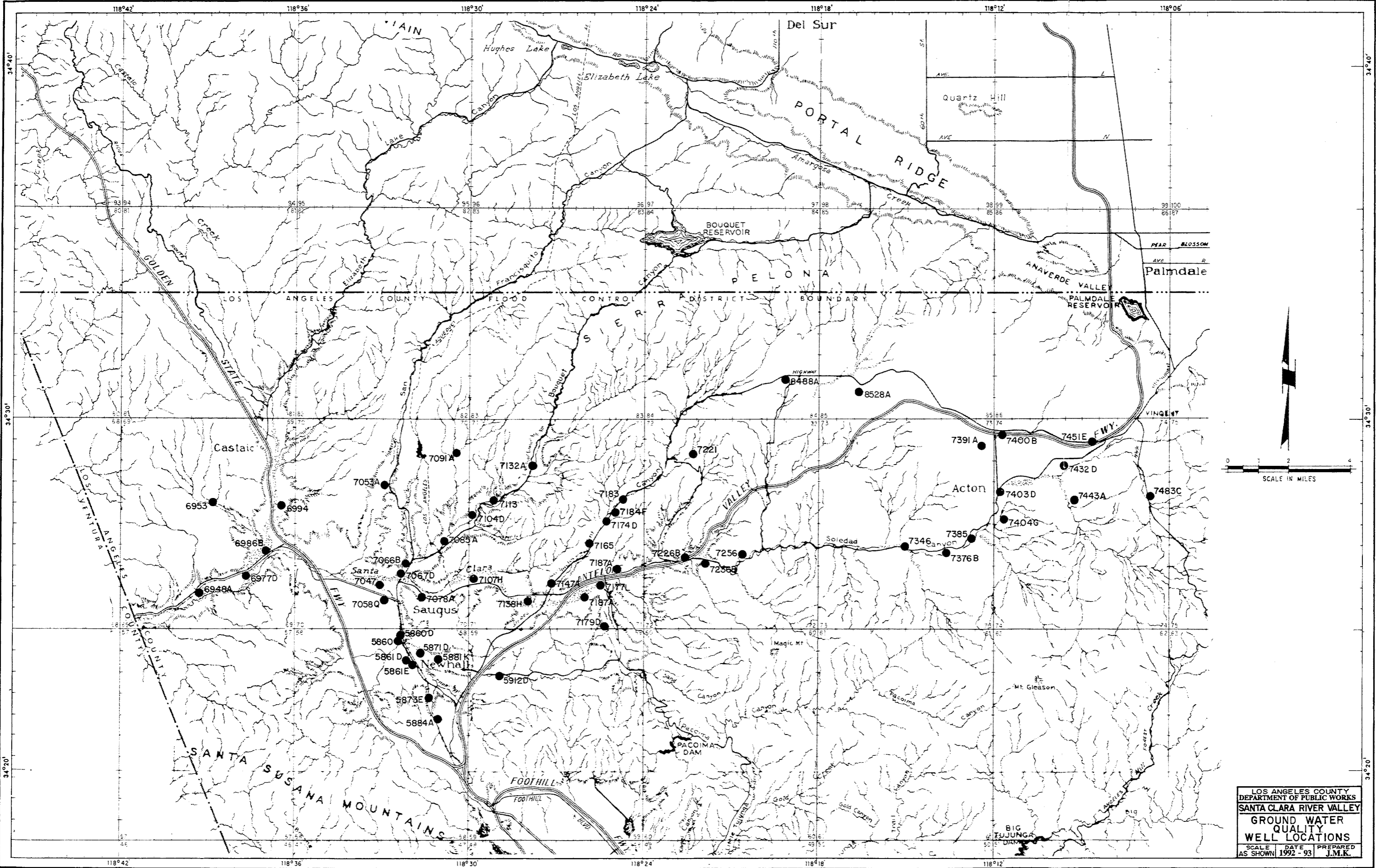

LOS ANGELES COUNTY
 DEPARTMENT OF PUBLIC WORKS
 SANTA CLARA RIVER VALLEY
 GROUND WATER
 QUALITY
 WELL LOCATIONS
 SCALE AS SHOWN | DATE 1992 - 93 | PREPARED BY J.M.K.

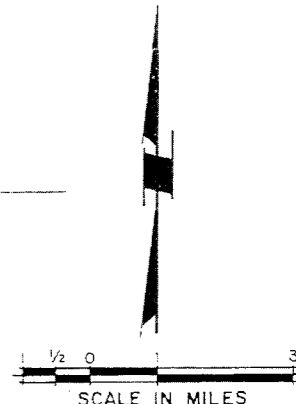
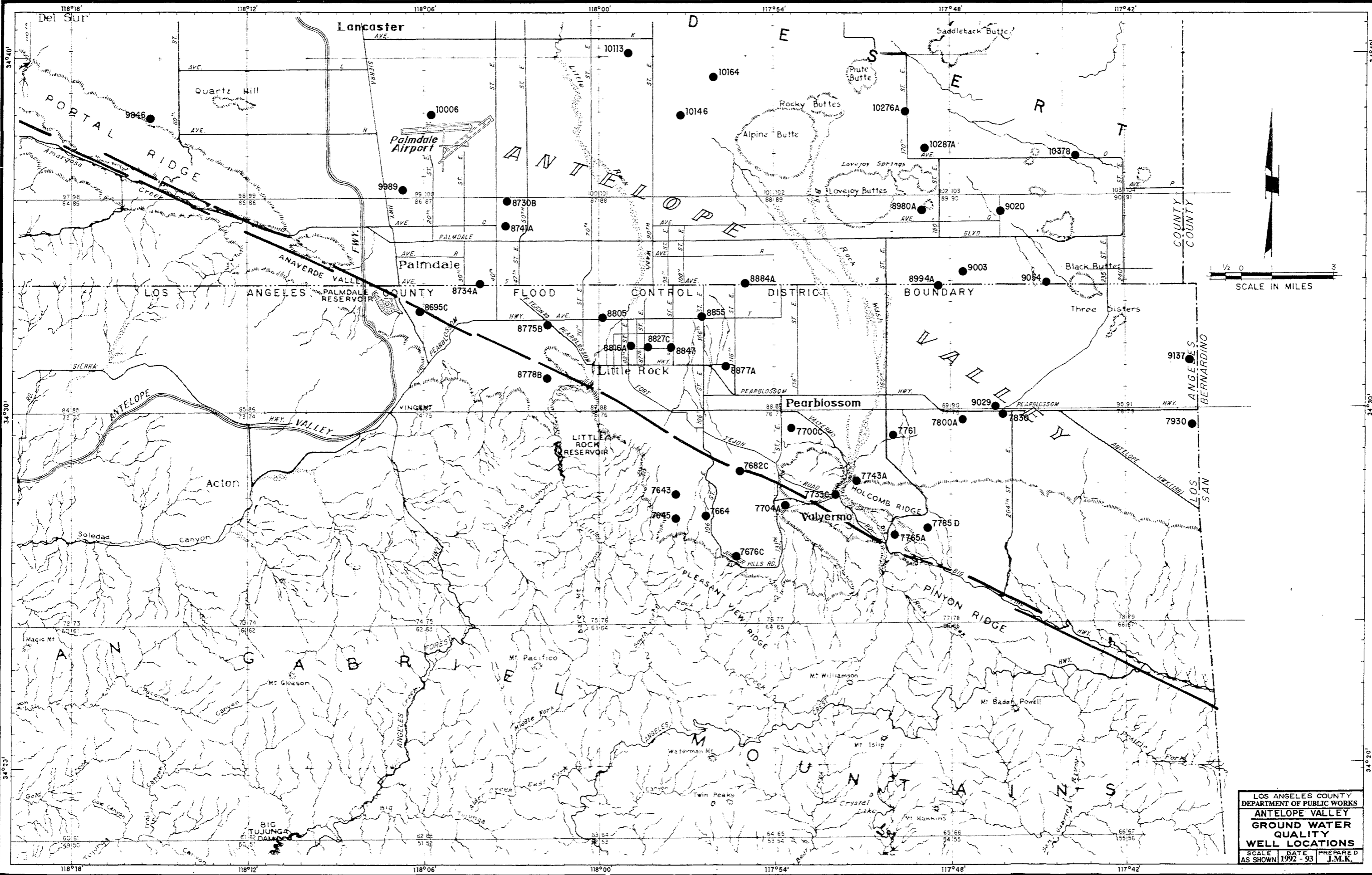

LOS ANGELES COUNTY
 DEPARTMENT OF PUBLIC WORKS
ANTELOPE VALLEY
GROUND WATER
QUALITY
WELL LOCATIONS
 SCALE DATE PREPARED
 AS SHOWN 1992 - 93 J.M.K.

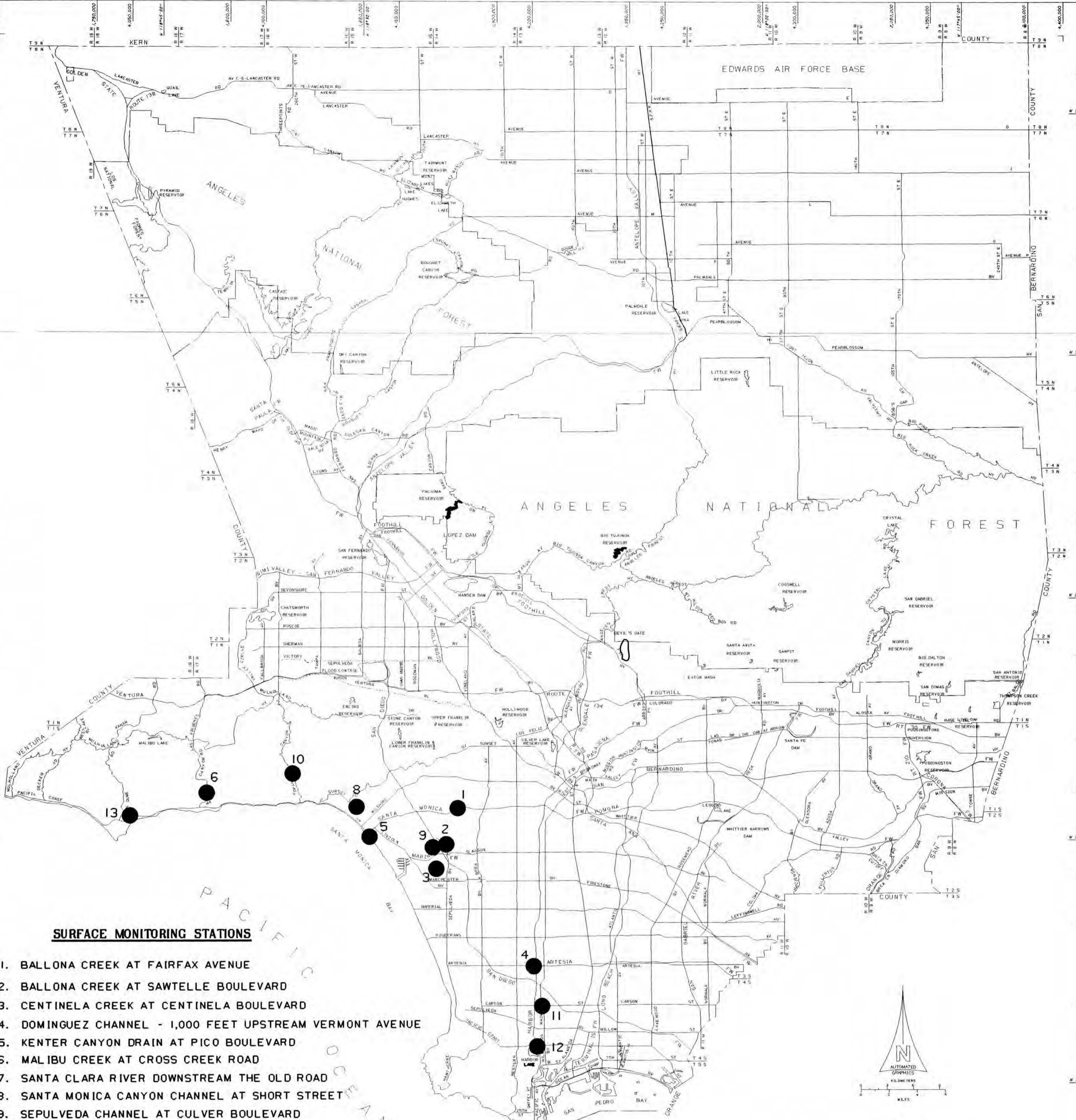

SURFACE MONITORING STATIONS

1. BALLONA CREEK AT FAIRFAX AVENUE
2. BALLONA CREEK AT SAWTELLE BOULEVARD
3. CENTINELA CREEK AT CENTINELA BOULEVARD
4. DOMINGUEZ CHANNEL - 1,000 FEET UPSTREAM VERMONT AVENUE
5. KENTER CANYON DRAIN AT PICO BOULEVARD
6. MALIBU CREEK AT CROSS CREEK ROAD
7. SANTA CLARA RIVER DOWNSTREAM THE OLD ROAD
8. SANTA MONICA CANYON CHANNEL AT SHORT STREET
9. SEPULVEDA CHANNEL AT CULVER BOULEVARD
10. TOPONGA CANYON CREEK AT PCH
11. TORRANCE LATERAL AT MAIN STREET
12. WILMINGTON DRAWIN AT PACIFIC COAST HIGHWAY
13. CORRAL CANYON CREEK AT PACIFIC COAST HIGHWAY

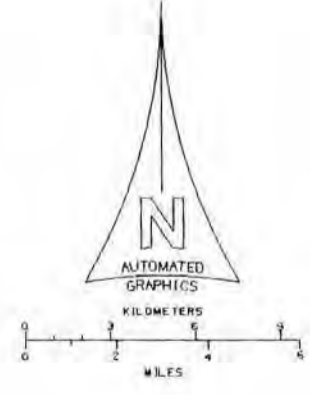

MAP OF
COUNTY OF LOS ANGELES
 DEPARTMENT OF PUBLIC WORKS
SURFACE MONITORING STATIONS
 GROUP I

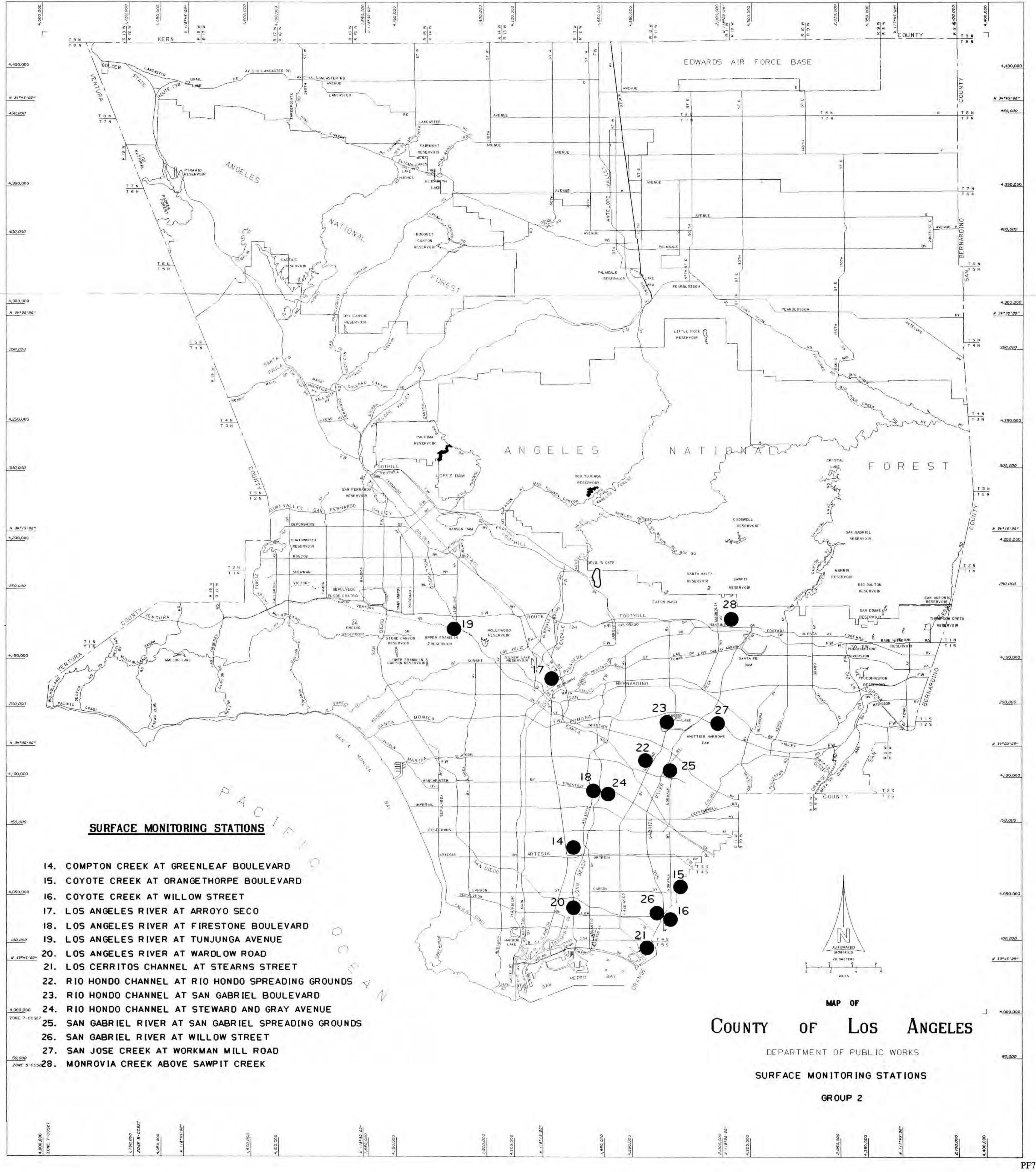

SURFACE MONITORING STATIONS

- 14. COMPTON CREEK AT GREENLEAF BOULEVARD
- 15. COYOTE CREEK AT ORANGETHORPE BOULEVARD
- 16. COYOTE CREEK AT WILLOW STREET
- 17. LOS ANGELES RIVER AT ARROYO SECO
- 18. LOS ANGELES RIVER AT FIRESTONE BOULEVARD
- 19. LOS ANGELES RIVER AT TUNJUNGA AVENUE
- 20. LOS ANGELES RIVER AT WARDLOW ROAD
- 21. LOS CERRITOS CHANNEL AT STEARNS STREET
- 22. RIO HONDO CHANNEL AT RIO HONDO SPREADING GROUNDS
- 23. RIO HONDO CHANNEL AT SAN GABRIEL BOULEVARD
- 24. RIO HONDO CHANNEL AT STEWARD AND GRAY AVENUE
- 25. SAN GABRIEL RIVER AT SAN GABRIEL SPREADING GROUNDS
- 26. SAN GABRIEL RIVER AT WILLOW STREET
- 27. SAN JOSE CREEK AT WORKMAN MILL ROAD
- 28. MONROVIA CREEK ABOVE SAWPIT CREEK

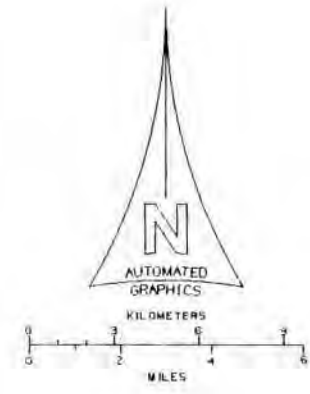

MAP OF
COUNTY OF LOS ANGELES

DEPARTMENT OF PUBLIC WORKS
SURFACE MONITORING STATIONS

GROUP 2

4,000,000 ZONE 7-CCS27
1,750,000 ZONE 5-CCS27
4,050,000
1,775,000
4,100,000
1,800,000
4,150,000
1,825,000
4,200,000
1,850,000
4,250,000
1,875,000
4,300,000
1,900,000
4,350,000
1,925,000
4,400,000
1,950,000
4,450,000
1,975,000
4,500,000
1,000,000
1,025,000
1,050,000
1,075,000
1,100,000
1,125,000
1,150,000
1,175,000
1,200,000
1,225,000
1,250,000
1,275,000
1,300,000
1,325,000
1,350,000
1,375,000
1,400,000
1,425,000
1,450,000

WATER CONSERVATION

WATER CONSERVATION

Information presented in this section includes amounts of local, imported, and reclaimed water conserved in spreading areas and information on the seawater barrier projects which prevent saltwater intrusion to groundwater zones in the coastal areas. Pertinent data is presented regarding the locations and descriptions of Department water conservation facilities, as well as facilities owned by others. Also included are groundwater maps delineating static groundwater elevations recorded during the report period and hydrographs of selected key wells.

CONSERVING THE WATERS

In addition to the flood control program, the Department has the equally important task of conserving as much of the storm and other waters as practicable. The use of water conservation facilities adjacent to river channels, and in soft-bottom channels permits water to percolate into groundwater basins for later pumping. These water spreading facilities are located in areas where the underlying soils are composed of permeable formations.

The various types of water conserved, local, imported, and reclaimed, are construed to have the following meanings in this section: Local water is primarily runoff due to rainfall on the mountain and valley watersheds, dam releases, and rising water within the County. Imported water is water originating outside the County either from Northern California or from the Colorado River. Reclaimed water is the effluent produced by the Whittier Narrows Water Reclamation Plant, the San Jose Creek Water Reclamation Plant, and the Pomona Reclamation Plant, all operated by the Los Angeles County Sanitation District.

The importance of this activity is apparent when it is realized that about 30 to 40 percent of the water used in the County is pumped from ground supplies. The growth of the County, combined with periodic droughts, has seriously depleted these supplies on numerous occasions.

The Department's policy is to conserve the maximum possible amount of storm water consistent with considering runoff quantity and quality, capacities of the spreading facilities, and groundwater conditions.

IMPORTED WATER

During this report period, imported Colorado River and State Project water for spreading was received from the Metropolitan Water District (MWD). Imported water for groundwater recharge in the Coastal Plain was spread at the Department's facilities in the Rio Hondo and San Gabriel Coastal Basin Spreading Grounds on behalf of the Water Replenishment District of Southern California. Imported water for groundwater recharge in the San Gabriel Valley was spread in Santa Fe Spreading Grounds, in the San Gabriel River, in Irwindale Spreading Basin/Manning Pit, and in Forbes Spreading Grounds on behalf of MWD, the Main San Gabriel Basin Watermaster, Three Valleys Municipal Water District, and the San Gabriel Valley Municipal Water District.

RECLAIMED WATER

The County Sanitation District's Whittier Narrows Water Reclamation Plant effluent, purchased by the Water Replenishment District of Southern California, was transported to the Rio Hondo and San Gabriel Coastal Basin Spreading Grounds for groundwater replenishment.

The County Sanitation District's San Jose Creek Water Reclamation Plant, activated in May 1972, made its first delivery of effluent in November 1972. The portion of the effluent that is spread is also purchased by the Water Replenishment District of Southern California.

Water from the Pomona Reclamation Plant is released down the San Jose Creek - San Gabriel River System to the Department's recharge facilities in the Rio Hondo and San Gabriel Coastal Basin spreading grounds.

The maximum amount of reclaimed water allowed for spreading in the Montebello Forebay, effective July 1991, is 60,000 acre-feet per year, but not to exceed 150,000 acre-feet over a three year period.

SEAWATER BARRIER PROJECTS

The Department operates three barrier projects to protect the groundwater in the West Coast and Central Basins against seawater intrusion by creating freshwater pressure ridges along the coastline. The pressure ridges are created by injecting fresh water through a series of injection wells. During the report period, 21,516 acre-feet of water was injected at the West Coast Basin Barrier Project, 4,910 acre-feet at the Dominguez Gap Barrier Project, and 3,351 acre-feet at the Los Angeles part of the Alamitos Barrier Project. On behalf of the Orange County Water District, 1,566 acre-feet of water was injected at the Orange County portion of the Alamitos Barrier Project.

The following seawater barrier improvements were completed during the 1992-93 water year:

1. Alamitos Barrier Project:

Orange County Water District drilled 4 new injection wells.

2. Dominguez Gap Barrier Project

Construction is completed on ten multizone observation wells. The geohydrologic information gathered from this drilling contract will be used for determination of the required remedial improvements for mitigating intrusion around the North-South leg of the barrier.

3. West Coast Basin Barrier Project

During this period the construction of three injection wells and two observation wells was completed.

These wells were constructed as part of the Department's consultant study recommendations to mitigate barrier deficiencies in the Silverado and Lower San Pedro aquifers.

SEASONAL DATA AND MAPS

During this report period, weekly, monthly, and semi-annual measurements of groundwater levels in observation wells located throughout the groundwater basins in Los Angeles County were made and processed.

Hydrographs of selected key wells are included in this report.

GROUNDWATER BASINS AND GROUNDWATER RECHARGE

Groundwater in Los Angeles County is stored in basins underlying five major geographic areas. These groundwater basins are separated by geologic features which impede groundwater movement or sometimes by arbitrary political boundaries. The following is a background summary of the Department's groundwater recharge activities within each of these areas:

The Department operates 2,436 acres of spreading grounds and soft-bottom channel spreading areas for replenishment of local groundwater supplies. The Department also assisted in the operation and maintenance of 269 acres of spreading grounds owned by others. An additional 656 acres of spreading grounds are controlled, maintained, and operated by other agencies. The total gross acreage of spreading grounds in the county is 3,361 acres. During the report period, above normal rainfall allowed the Department to conserve approximately 464,676 acre-feet of storm runoff.

The conservation of local runoff is supplemented by spreading imported water and reclaimed water purchased by water agencies. During the period, 64,751 acre-feet of imported water and 48,862 acre-feet of reclaimed water were spread.

The Department is continuing its efforts to improve its water spreading facilities in order to maximize the amounts of water conserved and to simplify the spreading operations.

SAN GABRIEL VALLEY

The Department operates 20 spreading facilities in the San Gabriel Valley that receive direct valley runoff and flows from the San Gabriel Mountains. Some of these spreading facilities can also receive imported water. During the report period, the Department added approximately 244,352 acre-feet of local water and 50,519 acre-feet of imported water to the

groundwater stored in the basins underlying the San Gabriel Valley and diverted 6,250 acre-feet of local water to grounds owned by others.

Main San Gabriel Basin

This is the largest basin underlying the San Gabriel Valley with an estimated storage capacity of 9.5 million acre-feet. It reacts quickly to artificial spreading in Santa Fe Reservoir Spreading Grounds and to infiltration in the San Gabriel River Downstream of Santa Fe Dam.

During the report period, the Department replenished the Main San Gabriel Basin with 179,067 acre-feet of local water and 36,559 acre-feet of imported water. Well 3030F in Baldwin Park recorded a high groundwater elevation for the report period of 271.5 ft on May 26, 1993.

Upper San Gabriel Canyon Basin

Approximately 48,071 acre-feet of local water and approximately 12,060 acre-feet of imported water were recharged by the Department through its San Gabriel Canyon Spreading Grounds and by percolation in the adjacent San Gabriel River. Also, 4,896 acre-feet of local water was routed to Fish Canyon Spreading Grounds which is operated by the Committee of Nine.

Lower San Gabriel Canyon Basin

The basin is located south of the Upper San Gabriel Canyon Basin and is separated from it by the underground Lohmon Dike. Groundwater cascades over the Lohmon Dike from the Upper San Gabriel Canyon Basin and recharges the Lower San Gabriel Canyon Basin. The Department spread 2,767 acre-feet of local water in Sawpit Spreading Grounds which is within the Lower Canyon Basin.

Wayhill Basin

The Department spread 107 acre-feet of local water and 1900 acre-feet of imported water at Forbes spreading facility in the Wayhill Basin.

Foothill Basin

The Department spread 3,034 acre-feet of local water at its San Dimas Canyon Spreading Grounds facility in the Foothill Basin.

Glendora Basin

The Department spread 2,181 acre-feet of local water in its Big and Little Dalton facilities within the Glendora Basin.

Claremont Heights Basin

The Department has no spreading facilities in the Claremont Heights Basin.

Live Oak Basin

The Department has no spreading facilities in the Live Oak Basin.

Chino Basin

The basin is located in the most eastern part of the County. No Department recharge facilities are located within the Chino Basin.

San Dimas Basin

The basin is north of the San Jose Hills, east of the Main Basin, and south of the Wayhill Basin. The Department spread 819 acre-feet of local water in its Live Oak Spreading Grounds to recharge the basin.

Pomona Basin

The basin is located south of Claremont, Live Oak, and San Dimas Basins, and north of the Chino Basin and northeast of the San Jose Hills. The Department has no water spreading facilities within this basin.

Puente and Spadra Basins

No spreading occurs in this area.

Raymond Basin

The basin covering approximately 40 square miles is located in the northwest corner of the San Gabriel Valley and is separated from the Main San Gabriel Basin by the Raymond Fault. The Raymond Basin contains the Monk Hill Basin and the Pasadena and Santa Anita Subareas. The Department recharged 8,306 acre-feet of local water by its spreading facilities in the Raymond Basin and diverted 1,354 acre-feet to the City of Sierra Madre's spreading facility during the report period.

COASTAL PLAIN

The groundwater basins underlying the Coastal Plain are divided by geological features into the Central (includes the Montebello and Los Angeles Forebays), West Coast, Santa Monica, and Hollywood Basins. During this report period, the Department recharged 150,161 acre-feet of local water, 14,100 acre-feet of imported water, and 48,862 acre-feet of reclaimed water to the groundwater basins underlying the Coastal Plain. Most of the water was spread in the Montebello Forebay.

Central Basin

The Central Basin has the most storage capacity of the basins in the Coastal Plain. In addition to the water recharged in the Department's spreading facilities, water injected in the Alamitos Barrier Project also contributes to the replenishment of the pressure aquifers underlying the Central Basin.

West Coast Basin

The West Coast Basin is the second largest basin underlying the Coastal Plain and is separated from the Central Basin by the Newport-Inglewood Fault zone. Groundwater is primarily recharged by Central Basin subsurface flows and by water injected by the Department in the West Coast Basin and Dominguez Gap Barrier Projects. Groundwater elevations in the West Coast Basin are below sea level except in the area of the West Coast Basin Barrier injection mound.

Santa Monica and Hollywood Basins

The Department has no spreading facilities in either the Santa Monica or Hollywood groundwater basins.

SAN FERNANDO VALLEY

The San Fernando Valley is also called the Upper Los Angeles River Area (ULARA). Most of the runoff from the surrounding mountains flows to the Valley.

San Fernando Main Basin

The basin is the largest basin underlying the San Fernando Valley. During the report period, 63,913 acre-feet of local water and 132 acre-feet of imported water were spread by the Department. The County entered into an agreement with the City of Los Angeles to spread water at the newly renovated Tujunga Wash Spreading Grounds which is located approximately two miles downstream of Hansen Spreading Grounds. The City installed a rubber dam diversion and appurtenant facilities for County Spreading operations which started in March 1990.

Sylmar Basin

A much smaller basin underlying the San Fernando Valley is the Sylmar Basin; the Department has no spreading facility within this basin.

Verdugo and Eagle Rock Basins

The small Verdugo and Eagle Rock Basins comprise the remaining basins underlying the San Fernando Valley. The Department has no spreading facilities within either basin.

SANTA CLARITA VALLEY

The Department has no spreading facilities in the area. Most of the Valley is farmland, permitting substantial natural percolation.

The Upper Santa Clarita subunit comprises five basins.

ANTELOPE VALLEY

There are several groundwater subbasins underlying the Antelope Valley. Five of them are located within Los Angeles County.

The Department operates no spreading facilities in the Antelope Valley.

The hydrographs for well Nos. 9974 and 8825 are shown on pages G41 and G43. They are located in the Lancaster and Little Rock subbasins respectively.

LOS ANGELES COUNTY DEPARTMENT OF PUBLIC WORKS
HYDRAULIC/WATER CONSERVATION DIVISION

SUMMARY OF DATA ON SPREADING FACILITIES
OWNED AND OPERATED BY THE DEPARTMENT
UPDATED THROUGH SEPTEMBER 1993

SPREADING FACILITY	TYPE	SEASON FIRST USED	AREA IN ACRES		CAPACITIES				LOCATION	SOURCE OF WATER	REMARKS
			GROSS	WETTED	CHANNEL** (CFS)	INTAKE (CFS)	STORAGE (A.F.)	PERCOLATION* (CFS)			
ARROYO SECO	SHALLOW BASINS	1948-49	24	15.1	-	75	30	18	EASTERLY SIDE OF ARROYO SECO, 0.5 MILES ABOVE DEVIL'S GATE DAM.	CONTROLLED FLOW FROM CITY OF PASADENA. UNCONTROLLED FROM ARROYO SECO AND THE ALTADENA STORM DRAIN.	SPREADING GROUNDS ARE HELD UNDER EASEMENT FROM THE CITY OF PASADENA.
BEN LOMOND	SHALLOW BASINS	1958-59	24	17.0	-	25	25	18	BOTH NORTH AND SOUTH SIDES OF SAN DIMAS WASH CHANNEL AT SOUTHWESTERLY CORNER OF INTERSECTION OF ARROW HIGHWAY AND BARRANCA AVENUE.	COVINA IRRIGATING COMPANY.	SPREADING GROUNDS UTILIZED TO CONSERVE EXCESS COVINA IRRIGATION COMPANY WATER RELEASED FROM THE COMMITTEE OF NINE.
BIG DALTON	SHALLOW BASINS	1930-31	24	7.7	-	45	12	12	WESTERLY SIDE OF BIG DALTON WASH, ONE HALF MILE ABOVE SIERRA MADRE AVENUE.	CONTROLLED FLOWS FROM BIG DALTON DAM AND BIG DALTON DEBRIS BASIN.	DIVIDED BASINS 2, 3, 4, AND 5, AND NOTCHED LEVEES TO ENABLE GROUNDS TO BE RUN IN BATTERY SYSTEM
BRANFORD	DEEP BASIN	1956-57	12	7	1,540	1,540	137	1	SOUTHWESTERLY OF ARLETA AVENUE ABOVE CONFLUENCE OF TUJUNGA WASH AND PACOIMA DIVERSION CHANNEL.	UNCONTROLLED FLOWS FROM BRANFORD STREET DRAIN.	INSTREAM SPREADING FACILITY. OUTLET CAPACITY 1,540 CFS TO PACOIMA DIVERSION CHANNEL.
BUENA VISTA	DEEP BASIN	1954-55	10	6	2,900	2,900	177	6	1.0 MILE EASTERLY OF SAWPIT WASH. 0.5 MILE NORTHERLY OF ARROW HIGHWAY, BETWEEN MERIDIAN STREET AND BUENA VISTA CHANNEL.	CONTROLLED FLOW FROM SANTA FE DAM AND UNCONTROLLED FLOW FROM BUENA VISTA CHANNEL.	INSTREAM SPREADING FACILITY. TOTAL OUTLET CAPACITY OF 270 CFS.
CITRUS	MEDIUM DEPTH BASINS	1960-61	19	14.6	-	200	80	28	SOUTH SIDE OF BIG DALTON WASH BETWEEN CITRUS AND CERRITOS AVENUES.	CONTROLLED FLOWS FROM BIG DALTON DAM AND LITTLE DALTON LITTLE DALTON DEBRIS DAMS. UNCONTROLLED FLOWS FROM BIG DALTON WASH.	THERE ARE 2 INTAKES, ONE IS A DROP INLET, THE OTHER AN AIR INFLATED RUBBER DAM.

* THE CAPACITIES LISTED ARE ESTIMATES OF INFILTRATION RATES WHICH MAY BE EXPECTED TO OCCUR DURING OPERATIONS FOR UP TO FIVE DAYS. NUMBERS DO NOT REFLECT LONG TERM SPREADING OPERATIONS.

** DESIGN CAPACITY OF MAIN CONCRETE CHANNEL

*** INCLUDES RUBBER DAMS STORAGE

LOS ANGELES COUNTY DEPARTMENT OF PUBLIC WORKS
HYDRAULIC/WATER CONSERVATION DIVISION

SUMMARY OF DATA ON SPREADING FACILITIES
OWNED AND OPERATED BY THE DEPARTMENT
UPDATED THROUGH SEPTEMBER 1993

SPREADING FACILITY	TYPE	SEASON	AREA IN ACRES		CAPACITIES				LOCATION	SOURCE OF WATER	REMARKS
		FIRST USED	GROSS	WETTED	CHANNEL** (CFS)	INTAKE (CFS)	STORAGE (A.F.)	PERCOLATION* (CFS)			
DOMINGUEZ GAP	DEEP BASINS	1957-58	54	23.8	-	20	234	1	SOUTH OF DEL AMO BOULEVARD AND BORDERS THE EASTERN AND WESTERN SIDES OF THE LOS ANGELES RIVER	CONTROLLED FLOW FROM LOS ANGELES RIVER LOW FLOW CHANNEL AND UNCONTROLLED FLOWS FROM STORM DRAINS.	EAST SIDE BASIN USED FOR FLOOD REGULATION WITH SOME CONSERVATION STORAGE. INTAKE CAPACITY IS 20 CFS FOR LOW FLOW DIVERSION FROM THE LOS ANGELES RIVER. THE WEST SIDE BASIN IS FED BY A 24-INCH CONCRETE PIPE FROM THE EAST SIDE BASIN.
EATON BASIN	DEEP BASIN	1956-57	16	10.5	9,600	400	284	10	EAST SIDE OF EATON WASH, NORTH OF DUARTE ROAD, 0.6 MILES SOUTH OF HUNTINGTON DRIVE.	CONTROLLED FLOW FROM EATON WASH DAM AND UNCONTROLLED FLOWS BETWEEN DAM AND SPREADING BASIN.	
EATON WASH	DEEP & SHALLOW BASINS	1947-48	28	25.4	6,600	200	525	14	EASTERLY SIDE OF EATON WASH FROM BELOW EATON DAM TO FOOTHILL BOULEVARD.	CONTROLLED FLOW FROM EATON WASH DAM.	GROUND MODIFICATIONS COMPLETED IN DECEMBER 1991.
FORBES	MEDIUM DEPTH BASINS	1964-65	21	10	-	100	87	5	SOUTH SIDE OF SAN DIMAS WASH BETWEEN LONE HILL AVENUE AND VALLEY CENTER AVENUE.	CONTROLLED RELEASES FROM PUDDINGSTONE DIVERSION DAM, AND UNCONTROLLED FLOWS FROM SAN DIMAS WASH; ALSO IMPORTED RELEASES FROM SGVMWD AND CB48.	RECONSTRUCTION OF BASINS, FROM SHALLOW TO MEDIUM DEPTHS, WAS COMPLETED IN APRIL 1989.
HANSEN	SHALLOW BASINS	1944-45	156	105.3	22,000	400	279	150	NORTHWESTERLY SIDE OF TUJUNGA WASH FROM ABOVE GLENOAKS BOULEVARD SOUTHWESTERLY TO SAN FERNANDO ROAD.	CONTROLLED FLOWS FROM HANSEN DAM AND BIG TUJUNGA DAM.	
IRWINDALE/MANNING PIT	DEEP BASINS	1958-59	62	30	20,000	400	1134	60	NORTHEASTERLY OF INTER-SECTION OF BIG DALTON CHANNEL AND IRWINDALE AVENUE; CONTINUES 1,300 FEET EAST OF IRWINDALE AVENUE	BIG DALTON CHANNEL CONTROLLED FLOWS FROM BIG AND LITTLE DALTON DEBRIS DAMS AND PUDDINGSTONE DIVERSION DAM; UNCONTROLLED FLOWS; ALSO IMPORTED RELEASES FROM CB48 AND SGVMWD.	MANNING PIT INTAKE COMPLETED MARCH 1991.
LITTLE DALTON	SHALLOW BASINS	1931-32	14	4.7	-	20	5	15	WESTERLY OF GLENDORA MT. ROAD, FROM LITTLE DALTON DEBRIS BASIN SOUTH TO EAST PALM DRIVE.	CONTROLLED FLOW FROM LITTLE DALTON DEBRIS BASIN.	
LIVE OAK	SHALLOW BASINS	1961-62	5	1.2	-	15	2	13	WESTERLY SIDE OF LIVE OAK WASH. NORTH OF BASE LINE ROAD (PROJECTED).	CONTROLLED FLOW FROM LIVE OAK DAM AND LIVE OAK DEBRIS BASIN.	

* THE CAPACITIES LISTED ARE ESTIMATES OF INFILTRATION RATES WHICH MAY BE EXPECTED TO OCCUR DURING OPERATIONS FOR UP TO FIVE DAYS. NUMBERS DO NOT REFLECT LONG TERM SPREADING OPERATIONS.

** DESIGN CAPACITY OF MAIN CONCRETE CHANNEL

*** INCLUDES RUBBER DAMS STORAGE

LOS ANGELES COUNTY DEPARTMENT OF PUBLIC WORKS
HYDRAULIC/WATER CONSERVATION DIVISION

SUMMARY OF DATA ON SPREADING FACILITIES
OWNED AND OPERATED BY THE DEPARTMENT
UPDATED THROUGH SEPTEMBER 1993

SPREADING FACILITY	TYPE	SEASON	AREA IN ACRES		CAPACITIES				LOCATION	SOURCE OF WATER	REMARKS
		FIRST USED	GROSS	WETTED	CHANNEL** (CFS)	INTAKE (CFS)	STORAGE (A.F.)	PERCOLATION* (CFS)			
LOPEZ	SHALLOW BASINS	1956-57	18	11.9	-	25	23.6	15	SOUTHEASTERLY SIDE OF PACOIMA WASH, NORTHEASTERLY OF FOOTHILL BOULEVARD.	CONTROLLED FLOW FROM PACOIMA DAM AND LOPEZ FLOOD CONTROL BASIN.	
PACOIMA	MEDIUM DEPTH BASINS	1932-33	169	107.3	17,000	600	440	65	BOTH SIDES OF OLD PACOIMA WASH CHANNEL FROM ARLETA AVENUE SOUTHWESTERLY TO WOODMAN AVENUE.	CONTROLLED FLOW FROM PACOIMA DAM. PARTIALLY CONTROLLED FLOW FROM LOPEZ FLOOD CONTROL BASIN, UNCONTROLLED FLOW FROM EAST CANYON AND PACOIMA WASH. IMPORTED WATER FROM OWENS VALLEY DELIVERED BY CITY OF LOS ANGELES.	MODIFICATIONS OF THE SPREADING GROUND WERE COMPLETED IN MARCH 1987.
PECK ROAD	DEEP BASIN	1959-60	157	105	30,100	30,100	3,347	25	CONFLUENCE OF SAWPIT AND SANTA ANITA WASHES.	CONTROLLED RELEASES FROM SANTA ANITA AND SAWPIT DEBRIS BASINS AND UNCONTROLLED FLOWS FROM LOCAL RUNOFF VIA SAWPIT AND SANTA ANITA WASHES.	INSTREAM SPREADING FACILITY.
RIO HONDO COASTAL	MEDIUM DEPTH BASINS	1937-38	570	430.1	40,000	1,950	3,694	400	EASTERLY SIDE OF RIO HONDO SOUTHERLY FROM S.P.R.R. (SOUTH OF WHITTIER BLVD.) TO SLAUSON AVENUE; WEST SIDE OF RIO HONDO CHANNEL FROM 0.2 MILE ABOVE WHITTIER BOULEVARD SOUTH TO FOSTER BRIDGE BOULEVARD.	CONTROLLED RELEASES FORM SAN GABRIEL CANYON DAMS, SANTA FE AND WHITTIER NARROWS DAMS. UNCONTROLLED RUNOFF VIA SAN GABRIEL RIVER, RIO HONDO CHANNEL AND THEIR TRIBUTARIES; ALSO IMPORTED AND RECLAIMED WATER.	IN COOPERATION WITH THE CORPS OF ENGINEERS. THE DISTRICT OPERATES 2,500 ACRE-FOOT POOL AT WHITTIER NARROWS DAM FOR RETENTION OF STORM WATER.
SAN DIMAS CANYON	SHALLOW BASINS	1965-66	22	10.8	-	25	22	12	SOUTHEAST SIDE OF SAN DIMAS WASH BETWEEN PUDDINGSTONE DIVERSION AND SAN DIMAS CANYON ROAD.	CONTROLLED RELEASES FROM PUDDINGSTONE DIVERSION DAM; UNCONTROLLED FLOW FROM LOCAL STORM RUNOFF.	CONSTRUCTED NEW BASINS IN SPILLWAY WASH. INSTALLED PIPELINES UNDER RAMOLA ST.
SAN GABRIEL CANYON	DEEP BASINS	1917	165	-	-	60	8170	35	EASTERLY SIDE OF SAN GABRIEL RIVER. BELOW MOUTH OF SAN GABRIEL CANYON. NORTH OF THE CITY OF AZUSA.	SAN GABRIEL RIVER CONTROLLED RELEASES FROM COGSWELL DAM, SAN GABRIEL DAM, AND MORRIS DAM. COMMITTEE OF NINE SURPLUS FLOWS.	
SAN GABRIEL COASTAL	MEDIUM DEPTH BASINS	1938-39	128	95.9	-	350	575	75	WESTERLY SIDE OF SAN GABRIEL RIVER, SOUTHERLY FROM WHITTIER BOULEVARD TO WASHINGTON BOULEVARD.	CONTROLLED RELEASES FROM SAN GABRIEL CANYON DAMS, SANTA FE AND WHITTIER NARROWS DAMS. ALSO IMPORTED AND RECLAIMED WATER.	IN COOPERATION WITH THE CORPS OF ENGINEERS. THE DISTRICT OPERATES 2,500 ACRE-FOOT POOL AT WHITTIER NARROWS DAM FOR RETENTION OF STORM WATERS.

* THE CAPACITIES LISTED ARE ESTIMATES OF INFILTRATION RATES WHICH MAY BE EXPECTED TO OCCUR DURING OPERATIONS FOR UP TO FIVE DAYS. NUMBERS DO NOT REFLECT LONG TERM SPREADING OPERATIONS.

** DESIGN CAPACITY OF MAIN CONCRETE CHANNEL

*** INCLUDES RUBBER DAMS STORAGE

LOS ANGELES COUNTY DEPARTMENT OF PUBLIC WORKS
HYDRAULIC/WATER CONSERVATION DIVISION

SUMMARY OF DATA ON SPREADING FACILITIES
OWNED AND OPERATED BY THE DEPARTMENT
UPDATED THROUGH SEPTEMBER 1993

SPREADING FACILITY	TYPE	SEASON	AREA IN ACRES		CAPACITIES				LOCATION	SOURCE OF WATER	REMARKS
		FIRST USED	GROSS	WETTED	CHANNEL** (CFS)	INTAKE (CFS)	STORAGE (A.F.)	PERCOLATION* (CFS)			
SAN GABRIEL RIVER (MONTEBELLO FOREBAY)	MEDIUM DEPTH BASINS	1954-55	156	156	20,000	550	1,462***	75	HEADWORKS TO FIRESTONE AVE ONLY. STORAGE BEHIND THE RUBBER DAMS.	SAME AS UPPER PORTION. ALSO RECLAIMED WATER.	FIVE RUBBER DAMS INSTALLED ON DROP STRUCTURES. WHEN INFLATED, CONVERTS RIVER BED TO SPREADING AREAS.
SAN GABRIEL RIVER (SAN GABRIEL VALLEY)	TEMPORARY CHECK LEVEES	1965-66	196	196	-	-	-	180	SAN GABRIEL RIVER FROM SANTA FE DAM.	CONTROLLED FLOW FROM DAMS IN SAN GABRIEL CANYON, SANTA FE DAM AND UNCONTROLLED VALLEY RUNOFF BELOW SANTA FE DAM; ALSO IMPORTED WATER.	CHECK LEVEES DEVELOPED IN RIVER TO SPREAD WATER.
SANTA ANITA	SHALLOW BASINS	1944-45	20	8.5	-	20	25	5	WESTERLY SIDE OF SANTA ANITA WASH 1.25 MILES ABOVE FOOTHILL BOULEVARD.	CONTROLLED FLOW FROM SANTA ANITA DAM AND SANTA ANITA DEBRIS BASIN.	THE HEADWORKS LOCATED UPSTREAM OF THE DEBRIS BASIN DIVERTS WATER TO SANTA ANITA SPREADING GROUNDS AND CITY OF SIERRA MADRE SPREADING GROUNDS.
SANTA FE	SHALLOW AND MEDIUM DEPTH BASINS	1953-54	338	168	-	400	540	400	WITHIN SANTA FE DAM RESERVOIR AND SPILLWAY AREAS.	CONTROLLED FLOWS FROM SAN GABRIEL CANYON RESERVOIRS. UNCONTROLLED FLOWS FROM SAN GABRIEL RIVER BELOW MORRIS RESERVOIR; ALSO IMPORTED WATER FROM SGVMWD AND USG-3.	RIGHT OF WAY, HELD UNDER LICENSE FROM THE FEDERAL GOVERNMENT INCLUDES 30 ACRES IN SAN GABRIEL RIVER BED FOR EARTH DIVERSION LEVEE. MODIFICATIONS OF GROUNDS, EAST OF 605 FWY, WAS COMPLETED IN FEB. 1990.
SAWPIT	SHALLOW BASINS	1946-47	12	3.8	-	30	13	12	WESTERLY SIDE OF SAWPIT WASH BELOW MOUTH OF CANYON NEAR NORUMBEGA DRIVE, MONROVIA.	CONTROLLED FLOWS FROM SAWPIT DAM AND SAWPIT DEBRIS BASIN.	
WALNUT	DEEP BASIN	1962-63	16	8.4	8,000	150	166	5	WEST SIDE OF WALNUT WASH, NORTH OF SAN BERNARDINO FREEWAY.	CONTROLLED FLOW FROM PUDDINGSTONE DAM AND UNCONTROLLED FLOWS FROM WALNUT WASH CHANNEL.	
TOTAL:			2,436	1,580	-	-	21,489	1,655			

* THE CAPACITIES LISTED ARE ESTIMATES OF INFILTRATION RATES WHICH MAY BE EXPECTED TO OCCUR DURING OPERATIONS FOR UP TO FIVE DAYS. NUMBERS DO NOT REFLECT LONG TERM SPREADING OPERATIONS.

** DESIGN CAPACITY OF MAIN CONCRETE CHANNEL

*** INCLUDES RUBBER DAMS STORAGE

LOS ANGELES COUNTY DEPARTMENT OF PUBLIC WORKS
HYDRAULIC/WATER CONSERVATION DIVISION

SUMMARY OF DATA ON SPREADING FACILITIES
NOT OWNED BY THE DEPARTMENT
UPDATED THROUGH SEPTEMBER 1993

GROUNDS	TYPE	SEASON	AREA IN ACRES		CAPACITIES				LOCATION	SOURCE OF WATER	REMARKS
		FIRST USED	GROSS	WETTED	CHANNEL**	INTAKE	STORAGE	PERCOLATION*			
					(CFS)	(CFS)	(A.F.)	(CFS)			
SIERRA MADRE (CITY OF SIERRA MADRE)	SHALLOW BASINS	ABOUT 1933	22	9	-	25	47	15	CITY OF SIERRA MADRE, SOUTH SIDE OF GRANDVIEW AVENUE, ONE HALF MILE WEST OF SANTA ANITA AVENUE.	LITTLE SANTA ANITA CREEK AND STREET RUNOFF ALSO CONTROLLED FLOWS FROM SANTA ANITA DAM.	THE DEPARTMENT DIVERTS WATER TO THESE FACILITIES.
FISH CANYON (COMMITTEE OF NINE)	SHALLOW BASINS	ABOUT 1917	6	4	-	-	-	7	WESTERLY SIDE OF SAN GABRIEL RIVER BELOW MOUTH OF FISH CANYON AND NORTH OF THE CITY OF AZUSA.	THE 'COMMITTEE OF NINE'.	OWNED AND OPERATED BY CAL-AMERICAN WATER COMPANY.
THOMPSON CREEK **** POMONA VALLEY PROTECTIVE ASSOCIATION	DITCHES CHECKS AND DEEP BASIN	ABOUT 1928	53	37	-	35	-	15	SOUTHERLY FROM, AND ADJACENT TO THOMPSON CREEK DAM, EAST SIDE OF CREEK. ELEVATION 1,625.	COBAL, WILLIAMS, PALMER, AND PADUA CREEKS, ALSO THOMPSON CREEK, WHEN RESERVOIR ABOVE	OPERATED BY POMONA VALLEY PROTECTIVE ASSOCIATION. THE DEPARTMENT DIVERTS WATER TO THESE FACILITIES.
TUJUNGA (L.A. CITY DEPT. OF WATER AND POWER) ***	SHALLOW BASINS	1931-32	188	83.2	22,000	400	100	120	SAN FERNANDO VALLEY, EAST SIDE OF TUJUNGA WASH AT ROSCOE BOULEVARD.	LOS ANGELES CITY'S OWENS VALLEY AQUEDUCT AND CONTROLLED RELEASES FROM HANSEN DAM.	THE DEPARTMENT ENTERED INTO AN AGREEMENT WITH THE CITY OF LOS ANGELES TO OPERATE THIS FACILITY.
TOTALS:			269	133	-	-	147	157			

* THE CAPACITIES LISTED ARE ESTIMATES OF INFILTRATION RATES WHICH MAY BE EXPECTED TO OCCUR DURING OPERATIONS FOR UP TO FIVE DAYS. NUMBERS DO NOT REFLECT LONG TERM SPREADING OPERATIONS.

** DESIGN CAPACITY OF MAIN CONCRETE CHANNEL.

Los Angeles County, Department of Public Works, Hydraulic / Water Conservation Division
WATER CONSERVED ALL FACILITIES FOR WATER YEAR 1992-1993

BASINS	SPREADING FACILITIES	OCT	NOV	DEC	JAN	FEB	MAR	APR	MAY	JUN	JUL	AUG	SEP	ACC. TOT
SAN FERNANDO VALLEY	BRANFORD	23.0	21.0	142.0	31.0	28.0	31.0	30.0	16.0	15.0	16.0	16.0	20.0	389.0
	HANSEN	0.0	100.0	2,525.0	1,648.0	826.8	9,211.0	4,285.0	3,213.0	2,263.0	977.0	746.0	391.0	26,185.8
	LOPEZ	0.3	0.0	119.0	161.0	21.0	216.0	263.0	348.0	184.0	0.0	0.0	0.0	1,312.3
	PACOIMA	0.0	142.0	969.0	2,936.2	3,320.3	4,006.8	1,860.8	2,031.1	1,202.1	33.0	0.0	0.0	16,501.3
	TUJUNGA	314.0	354.1	492.2	1,759.3	717.3	570.5	7,396.4	4,036.0	1,638.0	827.0	782.0	770.0	19,656.8
	SUBTOTAL	337.3	617.1	4,247.2	6,535.5	4,913.4	14,035.3	13,835.2	9,644.1	5,302.1	1,853.0	1,544.0	1,181.0	64,045.2
SAN GABRIEL VALLEY	ARROYO SECO	65.0	61.0	360.0	494.0	321.0	770.0	885.0	574.0	305.0	233.0	104.0	25.0	4,197.0
	BEN LOMOND	620.0	469.0	882.0	451.0	294.0	501.0	560.0	281.0	268.0	296.0	474.0	684.0	5,780.0
	BIG DALTON	0.0	0.0	0.0	107.0	37.0	87.0	159.0	138.0	75.0	39.0	4.2	5.2	651.4
	BUENA VISTA	45.0	0.0	114.0	107.0	110.0	28.0	0.0	0.0	35.0	6.0	0.0	0.0	445.0
	CITRUS	0.0	0.0	250.0	613.0	541.0	480.0	339.0	302.0	317.0	273.0	408.0	304.0	3,827.0
	EATON BASIN	102.0	0.0	211.0	376.0	434.0	542.0	209.0	50.0	99.0	30.0	19.0	30.0	2,102.0
	EATON GROUNDS	0.0	0.0	46.0	912.0	495.0	656.0	787.0	114.0	19.0	68.0	2.0	91.0	3,190.0
	FORBES	48.0	87.0	50.0	147.0	148.0	71.0	192.0	251.0	260.0	262.0	209.0	282.0	2,007.0
	IRWINDALE	40.0	1,600.0	2,070.0	1,970.0	1,730.0	1,260.0	1,590.0	1,540.0	1,070.0	1,140.0	1,060.0	1,130.0	16,200.0
	LITTLE DALTON	0.0	0.0	0.0	281.0	283.0	605.0	195.0	114.0	43.0	8.0	1.0	0.4	1,530.4
	LIVE OAK	0.0	0.0	17.0	115.0	140.0	320.0	37.0	105.0	41.0	25.0	2.0	17.0	819.0
	MORRIS TO STA. F190	2,943.0	3,342.0	3,389.0	8,779.0	7,997.0	6,604.0	6,311.0	5,988.0	1,961.0	2,620.0	2,366.0	1,912.0	54,212.0
	STA. F190 TO SANTA FE DAM	2,052.0	2,000.0	1,308.0	3,000.0	2,800.0	2,421.0	2,225.0	1,709.0	1,875.0	1,234.0	746.0	2,717.0	24,087.0
	PECK ROAD	1,172.0	0.0	1,202.0	1,055.0	108.0	1,865.0	2,145.0	1,003.0	155.0	606.0	0.0	0.0	9,311.0
	SAN DIMAS CANYON	1.0	22.0	156.0	447.0	268.0	519.0	674.0	366.0	433.0	148.0	0.0	0.0	3,034.0
	SAN GABRIEL CANYON	1,058.0	1,410.0	671.0	668.0	610.0	815.0	238.0	0.0	0.0	305.0	144.0	0.0	5,919.0
	SANTA ANITA	14.0	11.0	121.0	79.0	63.0	101.0	100.0	95.0	128.0	125.0	50.0	32.0	919.0
	SANTA FE SPRD. GROUNDS	133.0	5,560.0	1,670.0	6,790.0	5,734.0	13,709.0	17,908.0	12,803.0	799.0	0.0	2,420.0	6,000.0	73,526.0
	SANTA FE TO STA. F261	97.0	4,656.0	7,106.0	10,000.0	10,000.0	1,485.0	5,034.0	3,967.0	1,957.0	4,041.0	2,034.0	200.0	50,577.0
	SANTA FE DIVERSION	400.0	200.0	200.0	300.0	400.0	300.0	200.0	100.0	350.0	300.0	200.0	70.0	3,020.0
SAWPIT	42.0	55.0	138.0	243.0	280.0	529.0	387.0	338.0	300.0	129.0	209.0	117.0	2,767.0	
WALNUT	43.0	33.0	953.0	381.0	0.0	250.0	294.0	103.0	720.0	72.0	116.0	98.0	3,063.0	
WALNUT S. JOSE CRK TO 263	721.0	2,846.0	3,074.0	3,000.0	3,000.0	3,000.0	2,975.0	3,074.0	855.0	500.0	300.0	343.0	23,688.0	
	SUBTOTAL	9,596.0	22,352.0	23,988.0	40,315.0	35,793.0	36,918.0	43,444.0	33,015.0	12,065.0	12,460.0	10,868.2	14,057.6	294,871.8
COASTAL PLAIN	RIO HONDO EAST FLUME	5,770.0	3,910.0	5,350.0	5,570.0	4,020.0	3,560.0	2,130.0	1,270.0	4,680.0	1,950.0	2,882.0	1,860.0	42,952.0
	WEST FLUME	839.0	641.0	1,350.0	952.0	461.0	925.0	821.0	0.0	554.0	976.0	924.0	1,120.0	9,563.0
	R/W FLUME	2.7	0.0	282.0	849.0	595.0	358.0	160.0	9.9	155.0	346.0	140.0	99.0	2,996.6
	102" INTAKE	1,465.0	840.0	2,010.0	3,285.0	1,670.0	3,950.0	2,885.0	370.0	1,070.0	2,060.0	1,534.0	835.0	21,974.0
	RIO HONDO SYSTEM	6,999.0 *	1,627.8	10,933.0 *	13,356.0 *	3,142.0	3,491.0	2,100.0	1,490.0	7,386.0 *	1,098.0	1,729.0	700.0	54,051.8
	SAN GABRIEL SYSTEM	7,057.3	3,860.0	6,050.0	18,400.0	17,930.0	4,020.0	3,508.0	2,954.0	4,694.5	5,060.0	5,366.0	2,686.0	81,585.8
	DOMINGUEZ GAP	0.0	0.0	0.0	0.0	0.0	0.0	0.0	0.0	0.0	0.0	0.0	0.0	0.0
	SUBTOTAL	22,133.0	10,878.8	25,975.0	42,412.0	27,818.0	16,304.0	11,604.0	6,093.9	18,539.5	11,490.0	12,575.0	7,300.0	213,123.2
OTHER FACILITIES	SIERRA MADRE	139.0	140.0	17.0	0.0	0.0	47.0	28.0	96.0	322.0	358.0	128.0	79.0	1,354.0
	FISH CANYON	67.4	47.0	65.5	164.9	210.2	375.3	597.2	844.7	833.8	800.6	382.1	507.6	4,896.3
	SUBTOTAL	206.4	187.0	82.5	164.9	210.2	422.3	625.2	940.7	1,155.8	1,158.6	510.1	586.6	6,250.3
TOTAL OF ALL WATER SPREAD &/OR DIVERTED		32,272.7	34,034.9	54,292.7	89,427.4	68,734.6	67,679.6	69,508.4	49,693.7	37,062.4	26,961.6	25,497.3	23,125.2	578,290.5

NOTES: * : DATA ARE QUESTIONABLE.

Los Angeles County, Department of Public Works
Hydraulic Water Conservation Division

**Imported and Reclaimed Water Delivered in Acre-Foot
WATER YEAR : 1992-1993**

MONTH	IMPORTED WATER OUTLET RELEASES									RECLAIMED WATER DELIVERED									
	SAN DIMAS	THOMPSON CREEK	SAN GAB RIVER	ALHAMBRA	OLDEN ST	USG 3	BEATTY CANYON	SAN DIMAS WH	MONTHLY TOTAL	WHITTIER NARROWS PLANT			SAN JOSE PLANT			POMONA	MONTHLY TOTAL		
	CB - 48	CB - 28	CB - 37	CB - 36	L.A. 699	USGMWD	SGVMWD	SGVMWD	SPREAD	DELIVERED	WASTED	MONTHLY	DELIVERED	WASTED	MONTHLY	PLANT	SPREAD		
										R.HONDO	S.GABRIEL	SPREAD	R.HONDO	S.GABRIEL	SPREAD				
OCT	3,430.4	863.1	0.0	1,537.3	0.0	2,144.9	0.0	150.0	8,125.7	1,381.5	0.0	0.0	1,381.5	258.0	5,577.3	0.0	5,835.3	501.1	7,717.9
NOV	2,055.8	2,309.0	0.0	1,275.6	0.0	13,099.2	127.0	972.0	19,838.6	1,372.1	0.0	0.0	1,372.1	2,298.1	1,335.0	4.3	3,628.8	529.1	5,530.0
DEC	2,098.4	1,885.5	0.0	1,291.5	0.0	13,936.5	1,274.0	1,728.0	22,213.9	1,162.0	0.0	24.4	1,137.6	540.4	134.4	33.7	641.1	703.3	2,481.9
JAN	0.0	0.0	0.0	55.8	0.0	3,136.1	0.0	0.0	3,191.9	1,084.2	0.0	265.0	819.2	0.0	618.6	400.0	218.6	885.3	1,923.1
FEB	0.0	0.0	0.0	145.3	131.5	0.0	0.0	0.0	276.8	1,016.5	0.0	760.0	256.5	0.0	0.0	0.0	0.0	815.6	1,072.1
MAR	0.0	0.0	0.0	0.0	0.0	0.0	0.0	0.0	0.0	1,159.2	135.7	225.0	1,069.9	49.1	0.0	10.0	39.1	790.9	1,899.9
APR	0.0	0.0	0.0	0.0	0.0	0.0	0.0	2,012.0	2,012.0	544.2	637.0	0.0	1,181.2	0.0	114.7	0.0	114.7	592.3	1,888.2
MAY	0.0	0.0	0.0	0.0	0.0	0.0	0.0	2,337.0	2,337.0	881.3	382.8	0.0	1,264.1	0.0	91.4	0.0	91.4	371.1	1,726.6
JUN	0.0	0.0	0.0	0.0	0.0	0.0	0.0	1,657.0	1,657.0	878.7	78.7	2.5	954.9	0.0	2,761.8	0.0	2,761.8	263.0	3,979.7
JUL	0.0	0.0	0.0	0.0	0.0	0.0	0.0	1,715.0	1,715.0	1,001.0	100.0	0.0	1,101.0	0.0	4,527.2	0.0	4,527.2	346.4	5,974.6
AUG	0.0	0.0	0.0	0.0	0.0	0.0	0.0	1,628.0	1,628.0	969.9	41.8	0.0	1,011.7	1,357.9	5,381.9	0.0	6,739.8	382.8	8,134.3
SEP	0.0	0.0	0.0	0.0	0.0	0.0	0.0	1,755.0	1,755.0	840.9	0.0	0.0	840.9	1,731.0	3,595.8	0.0	5,326.8	365.9	6,533.6
TOTALS	7,584.6	5,057.6	0.0	4,305.5	131.5	32,316.7	1,401.0	13,954.0	64,750.9	12,291.5	1,376.0	1,276.9	12,390.6	6,234.5	24,138.1	448.0	29,924.6	6,546.8	48,861.9

NOTES :
 - The amounts of reclaimed water from Pomona Plant are estimated.
 - 1885.1 AF and 52 AF of water delivered from CB-48 during November 1992 and December 1992 respectively, were spread in San Gabriel Valley.

WELL HYDROGRAPHS INCLUDED IN THIS REPORT

GROUNDWATER BASIN	WELL NO.	APPROXIMATE LOCATION	PAGE NO.
WEST COAST	1346D 760C	11305 TRURO AVE., 250FT. N. OF IMPERIAL HWY., COMPTON 99 FT. S.W. OF INTERSECTION OF COMPTON BLVD. & DOTY AVE., LAWDALE	G19
CENTRAL BASIN	460K 1601T 906D	2,600 FT. N.E. OF THE INTERSECTION OF LAKEWOOD BLVD. & PACIFIC COAST HWY., LONG BEACH 1,000 FT. S. OF THE INTERSECTION OF WASHINGTON BLVD. & ROSEMEAD BLVD., MONTEBELLO 1,300 FT. N.W. OF THE INTERSECTION OF LONG BEACH & SAN ANTONIO DR., LONG BEACH	G21 G23 G25
MAIN SAN GABRIEL	3030F 2965C	600 FT. N.W. OF THE INTERSECTION OF LOS ANGELES ST. & MAINE AVE., BALDWIN PARK 100 FT. S.W. OF THIENES AVE. & 180 FT. N.W. OF DURFEE AVE. (NOW PECK ROAD)	G27 G29
SAN GABRIEL CANYON	4284A 4285	5,600 FT. N.W. OF THE INTERSECTION OF SIERRA MADRE AVE. & SAN GABRIEL CANYON ROAD., AZUSA 2,700 FT. N.W. OF SAN GABRIEL CANYON RD. & SIERRA MADRE AVE.	G31
POMONA	3251E 3261P 4469A	2,200 FT. N. OF THE INTERSECTION OF SAN BERNARDINO FWY. & TOWNE AVE., POMONA 630 FT. N.E. FROM INTERSECTION OF LA VERNE AVE. & 50 FT. S.E. OF CENTERLINE OF TOWNE AVE. 739 FT. W. OF MOUNTAIN AVE., 1,025 FT. N. OF HARRISON AVE.	G33
CLAREMONT HEIGHTS	4508B 4508A	800 FT. S.E. OF THE INTERSECTION OF BASELINE RD. & PADUA AVE., CLAREMONT 270 FT. N.W. OF WELL 4508	G35
RAYMOND	4057H	LOS ROBLES & GLENARM STREETS, PASADENA	G37
SANTA CLARA	7048A 7048C	S.E. OF THE INTERSECTION OF NEWHALL AVE. & MAGIC MOUNTAIN PARKWAY, SAUGUS 544 FT. W. OF W. CURB OF VALENCIA BLVD., 56 FT. S. OF MAGIC MOUNTAIN PARKWAY, VALENCIA	G39
ANTELOPE VALLEY	9974 8825	8,976 FT. S. OF AVE. K & 200 FT. W. OF SIERRA HWY., LANCASTER 25 FT. N. OF AVE. T & 45 FT. E. OF 90TH ST., LITTLE ROCK	G41 G43
MAIN SAN FERNANDO	3872H 4709	CLARK AVE. & GRIFFITH PARK DR., BURBANK SHERMAN WAY & DEERING AVE., CANOGA PARK	G45 G47

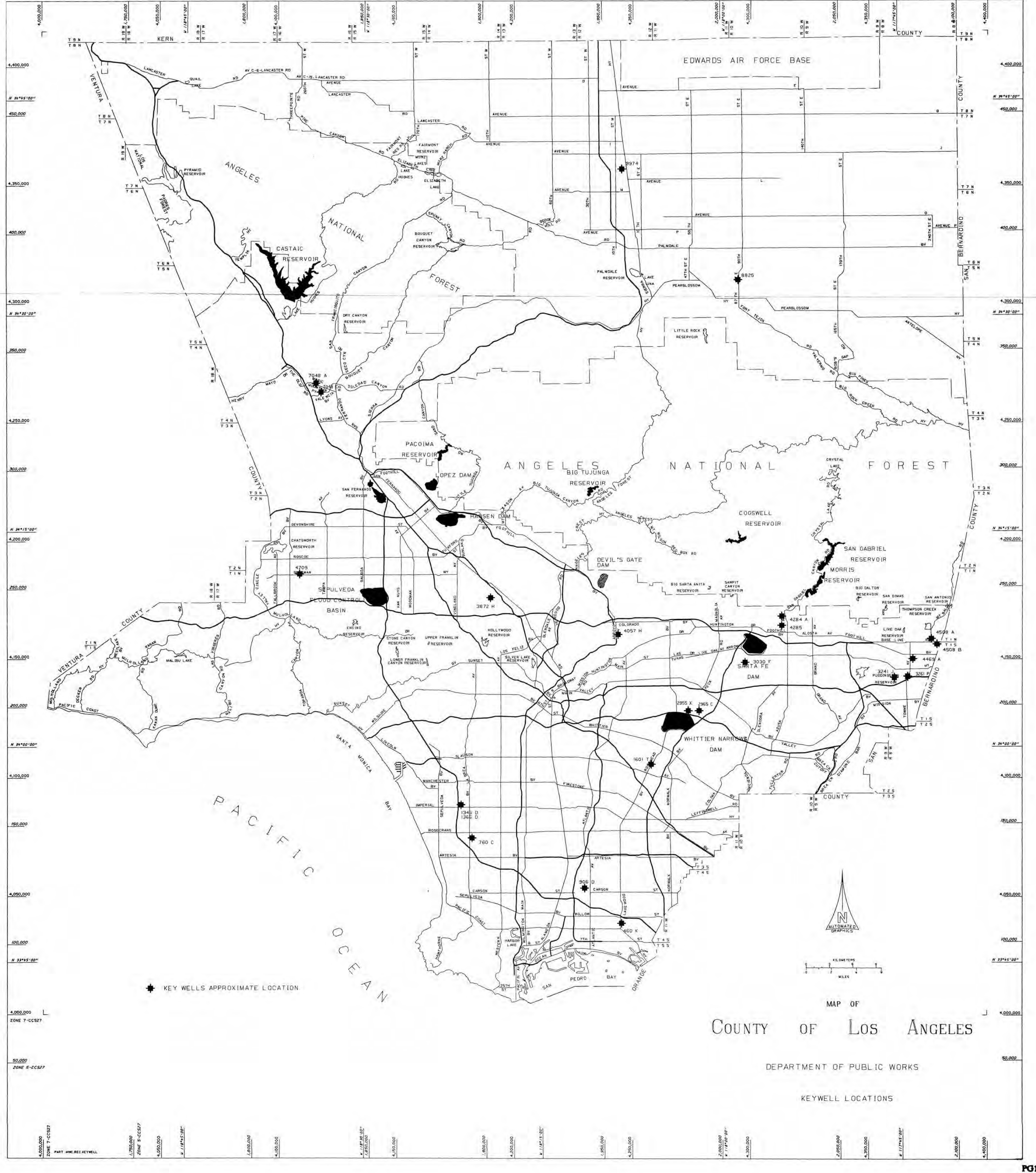

● KEY WELLS APPROXIMATE LOCATION

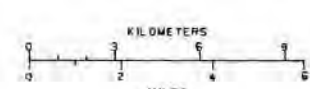
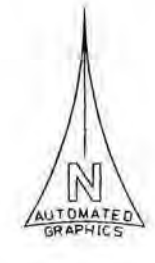

MAP OF
COUNTY OF LOS ANGELES

DEPARTMENT OF PUBLIC WORKS

KEYWELL LOCATIONS

4,000,000 ZONE 7-CC527
 3,750,000 ZONE 5-CC527
 3,500,000
 3,250,000
 3,000,000
 2,750,000
 2,500,000
 2,250,000
 2,000,000
 1,750,000
 1,500,000
 1,250,000
 1,000,000
 750,000
 500,000
 250,000
 0

117°45'00" W
 117°40'00" W
 117°35'00" W
 117°30'00" W
 117°25'00" W
 117°20'00" W
 117°15'00" W
 117°10'00" W
 117°05'00" W
 117°00'00" W

4,000,000
 3,750,000
 3,500,000
 3,250,000
 3,000,000
 2,750,000
 2,500,000
 2,250,000
 2,000,000
 1,750,000
 1,500,000
 1,250,000
 1,000,000
 750,000
 500,000
 250,000
 0

4,000,000 ZONE 7-CC527
 3,750,000 ZONE 5-CC527
 3,500,000
 3,250,000
 3,000,000
 2,750,000
 2,500,000
 2,250,000
 2,000,000
 1,750,000
 1,500,000
 1,250,000
 1,000,000
 750,000
 500,000
 250,000
 0

GROUNDWATER FLUCTUATIONS FOR WELL NOS. 1346D, 760C & 1366C COASTAL PLAIN

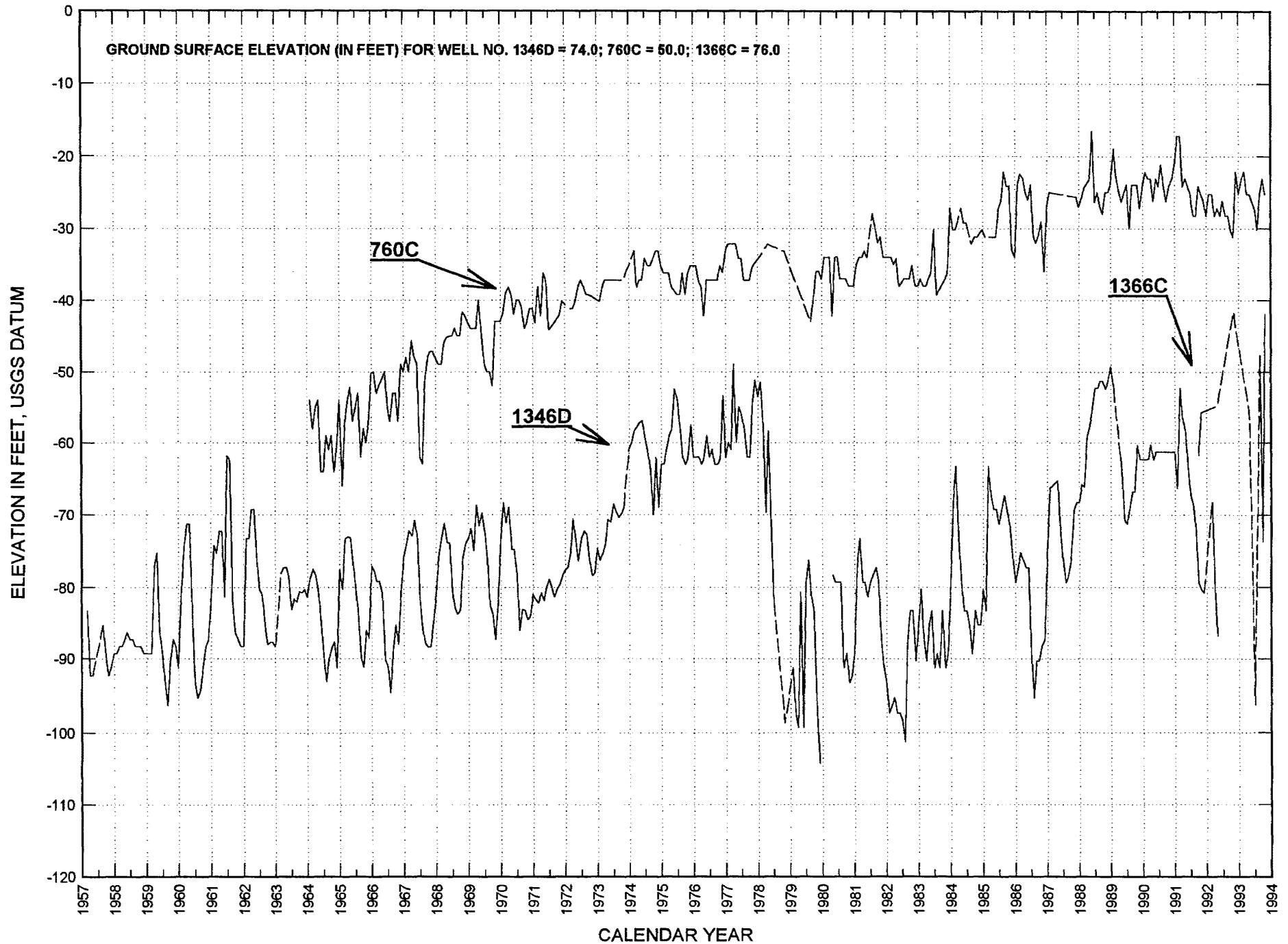

G19

GROUNDWATER FLUCTUATIONS FOR WELL NO. 460K

CITY OF LONG BEACH, COASTAL PLAIN FORMER ARTESIAN AREA

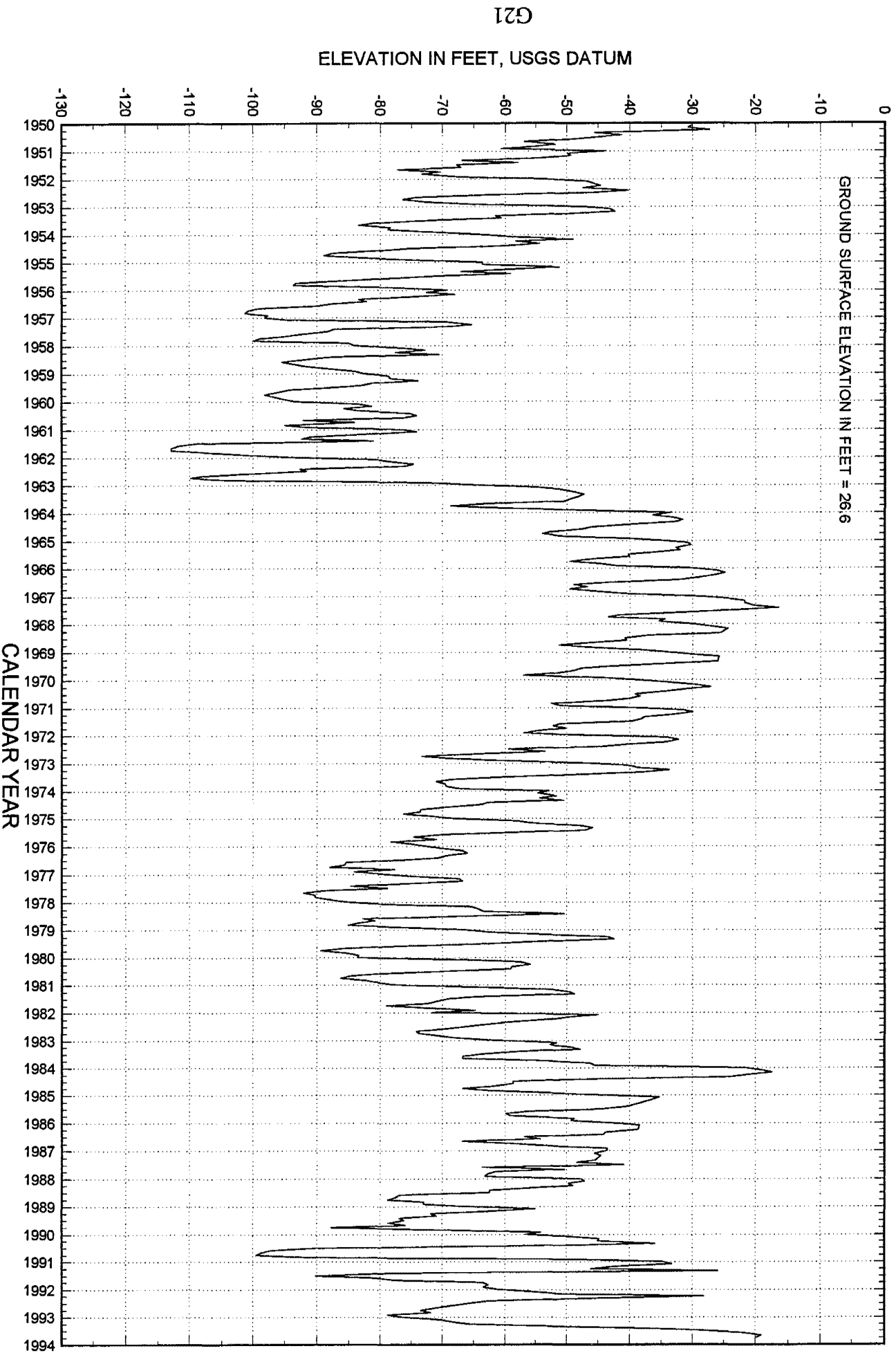

GROUNDWATER FLUCTUATIONS FOR WELL NO. 1601T

CENTRAL BASIN

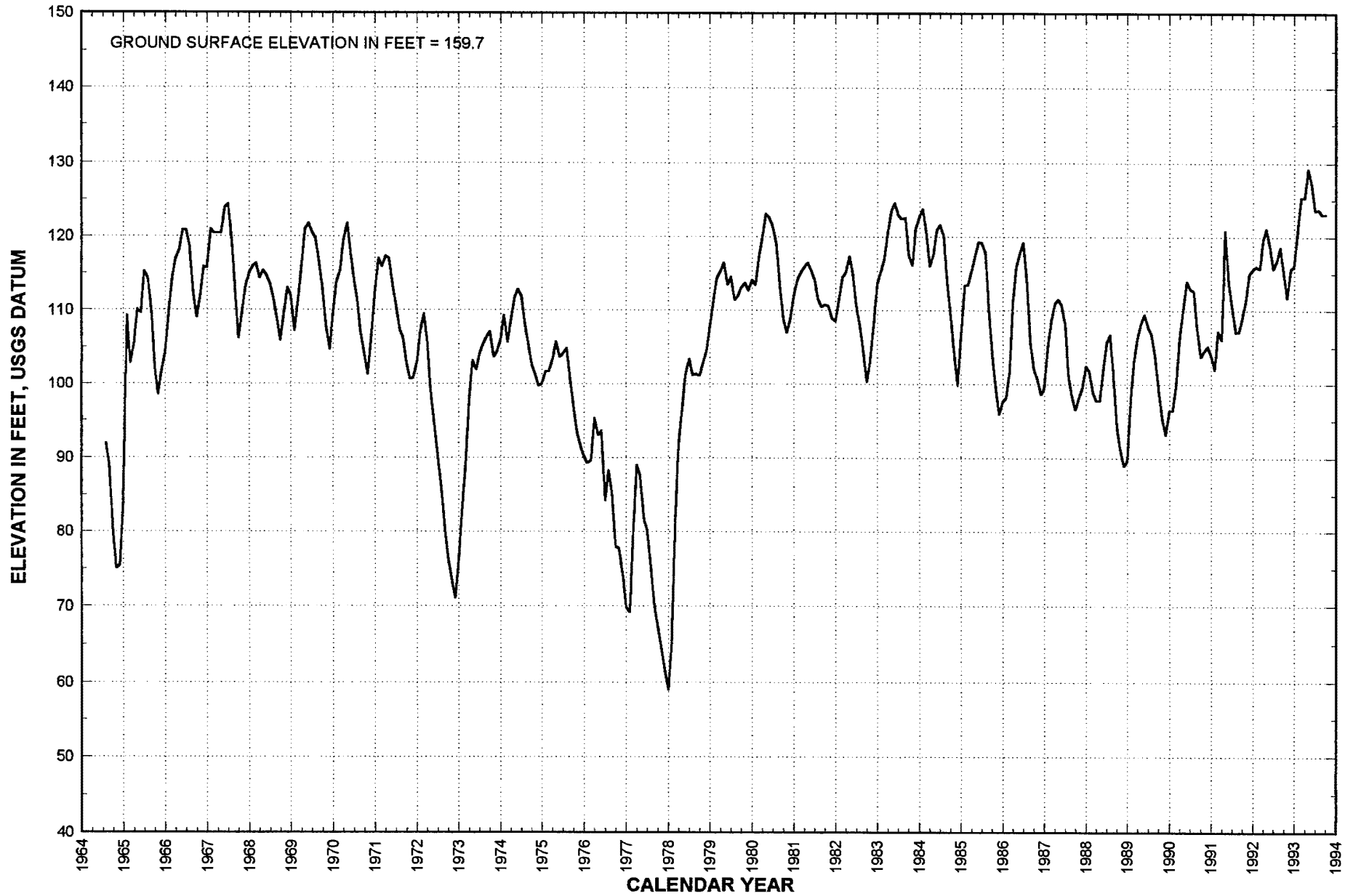

G23

GROUNDWATER FLUCTUATIONS FOR WELL NO. 906D CITY OF LONG BEACH, COASTAL PLAIN, FORMER ARTESIAN AREA

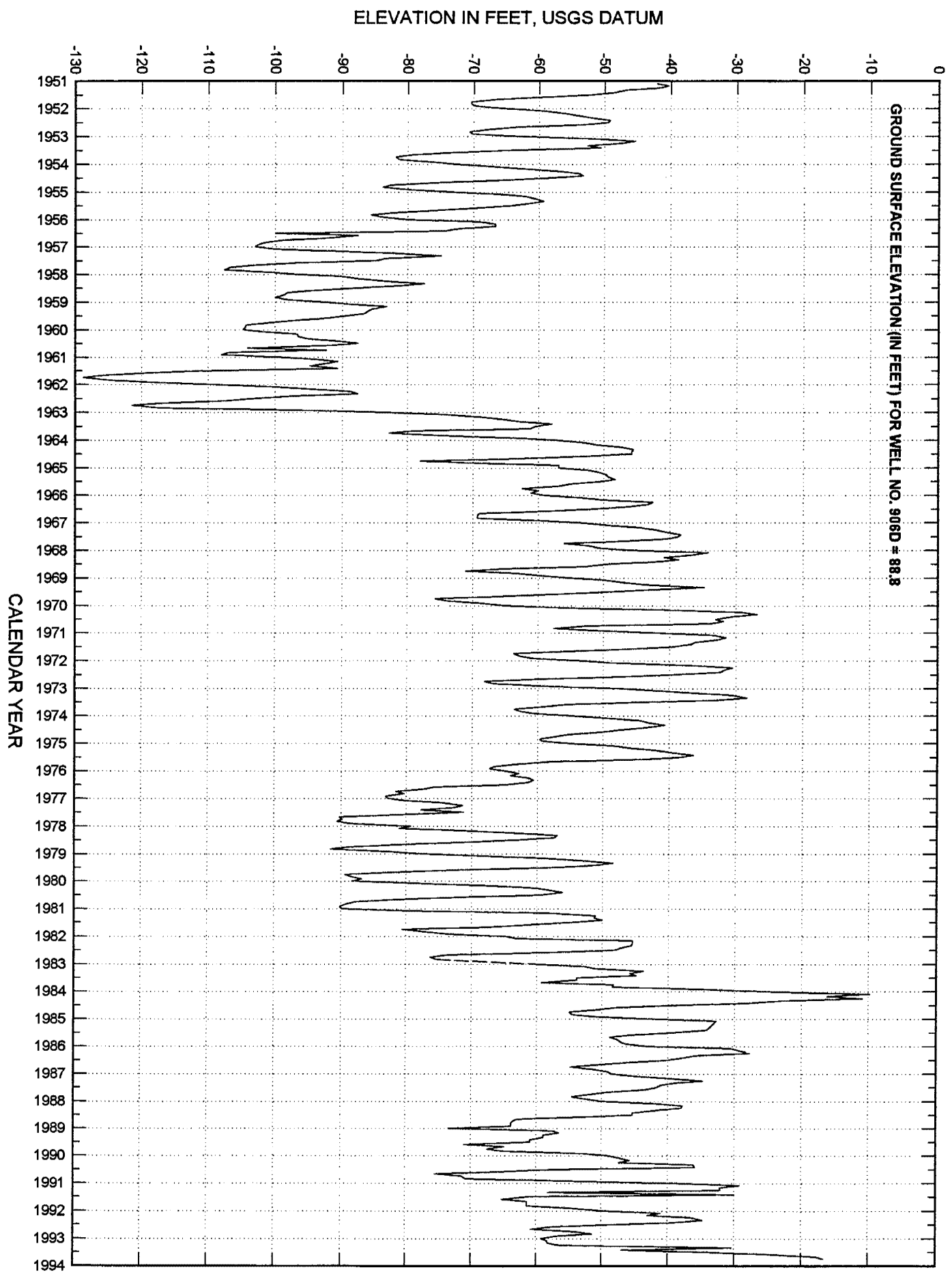

GROUNDWATER FLUCTUATIONS FOR WELL NO. 3030F

BALDWIN PARK, MAIN SAN GABRIEL BASIN

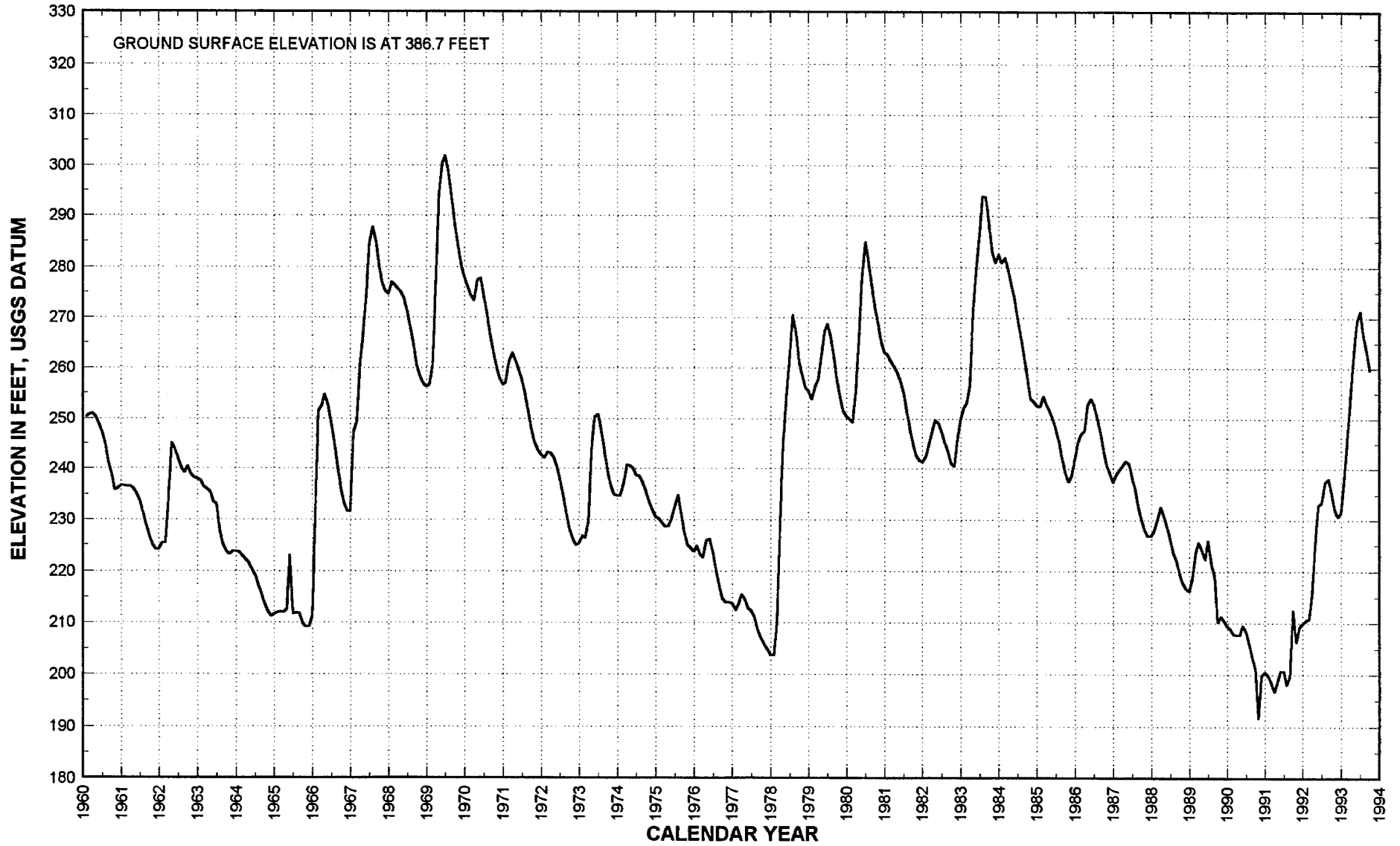

G27

GROUNDWATER FLUCTUATIONS FOR WELL NOS. 2955X & 2965C MAIN SAN GABRIEL BASIN

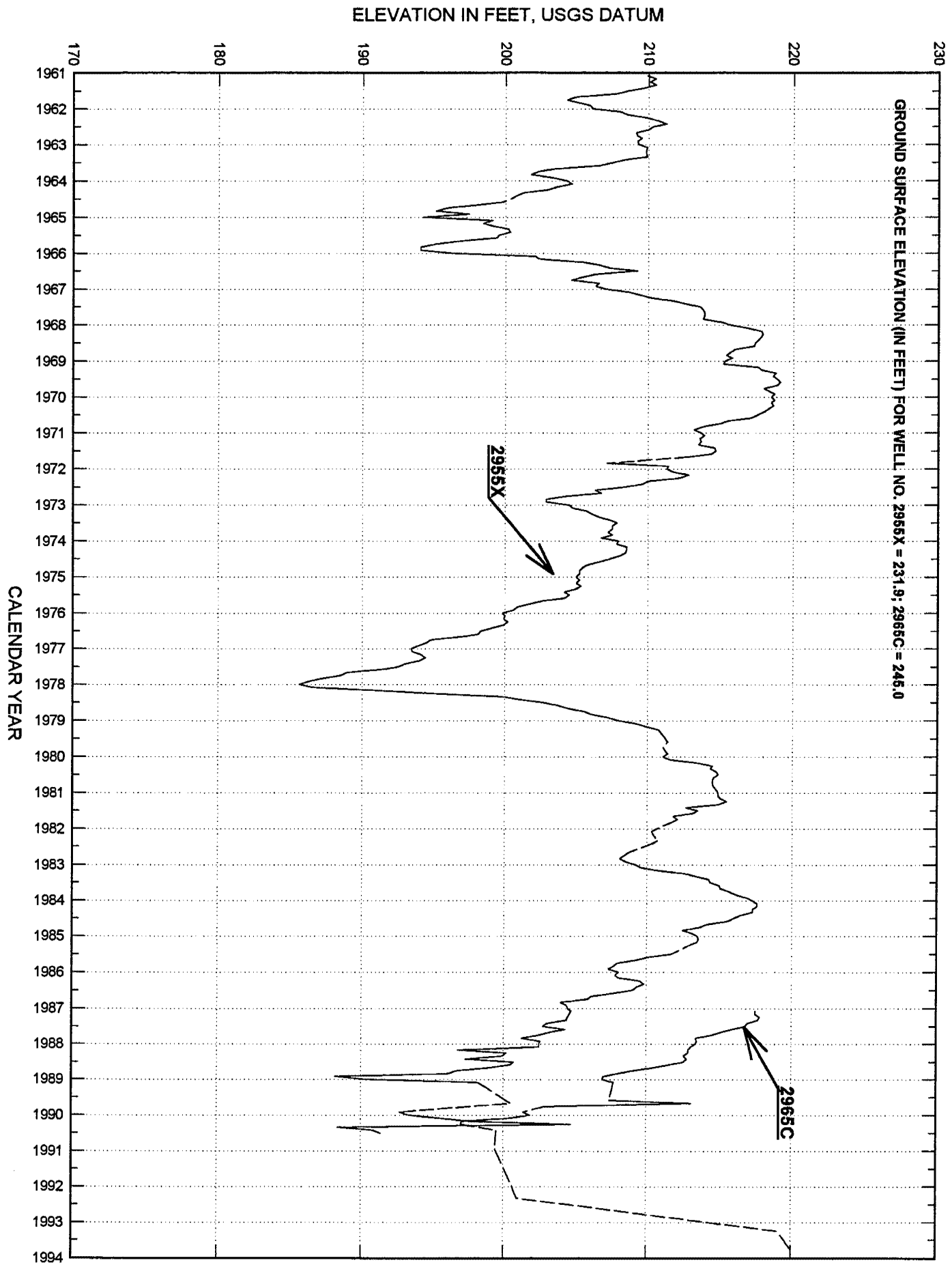

GROUNDWATER FLUCTUATIONS FOR WELL NOS. 4285 & 4284A

NORTH OF AZUSA; SAN GABRIEL CANYON BASIN

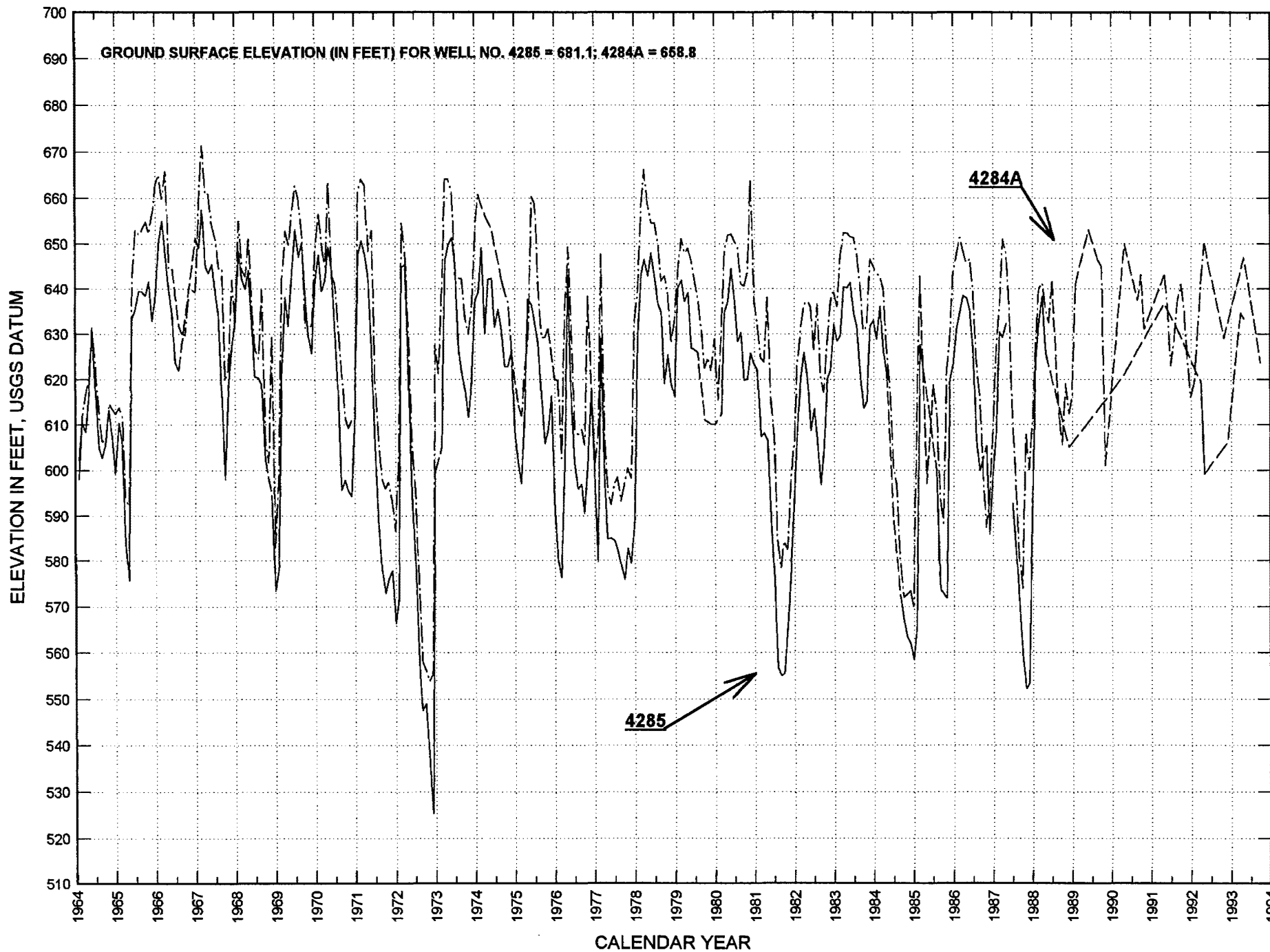

G31

GROUNDWATER FLUCTUATIONS FOR WELL NOS. 3251E, 3261P & 4469A POMONA BASIN

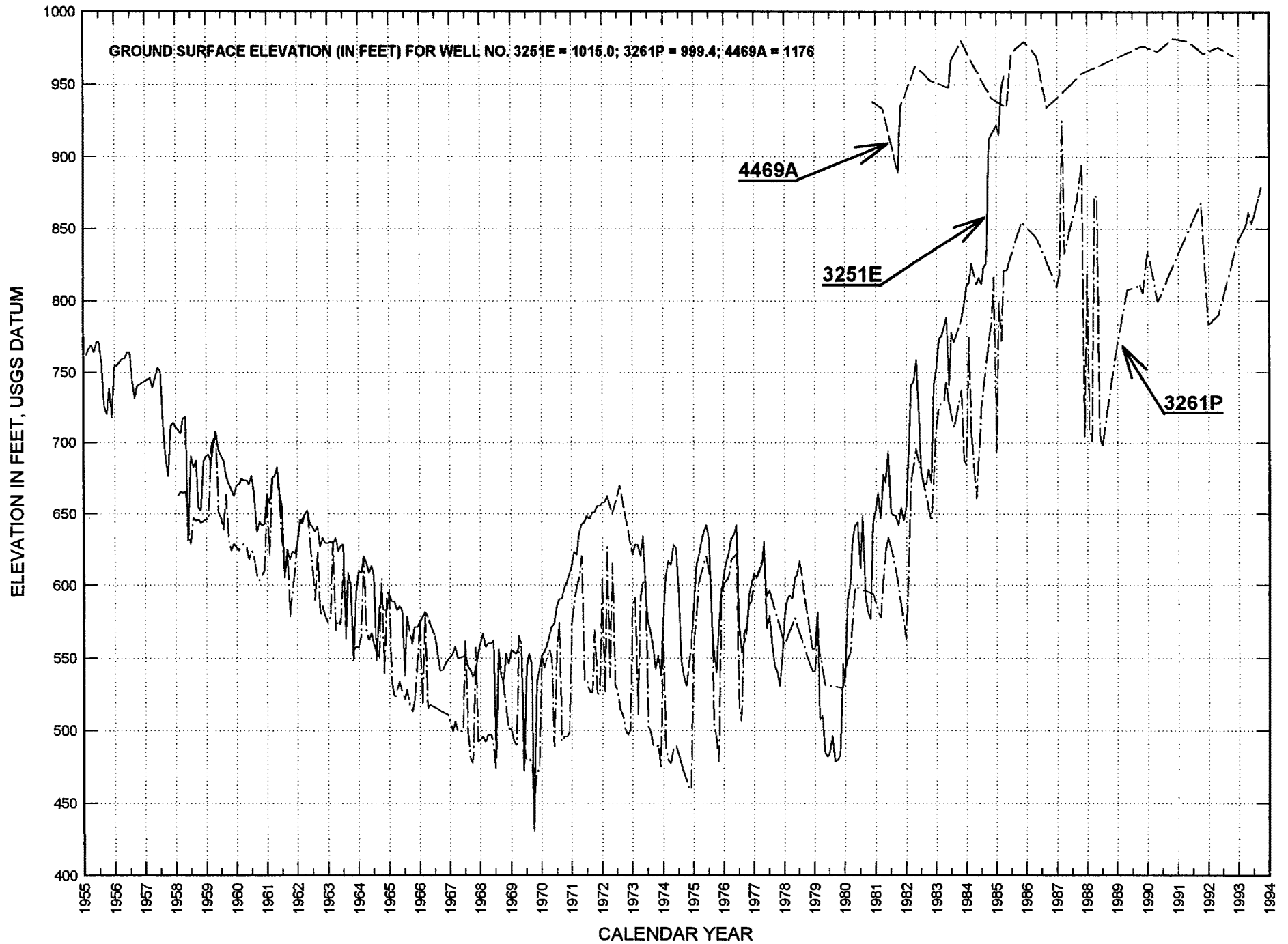

G33

GROUNDWATER FLUCTUATIONS FOR WELL NOS. 4508A & 4508B

UPPER CLAREMONT HEIGHTS

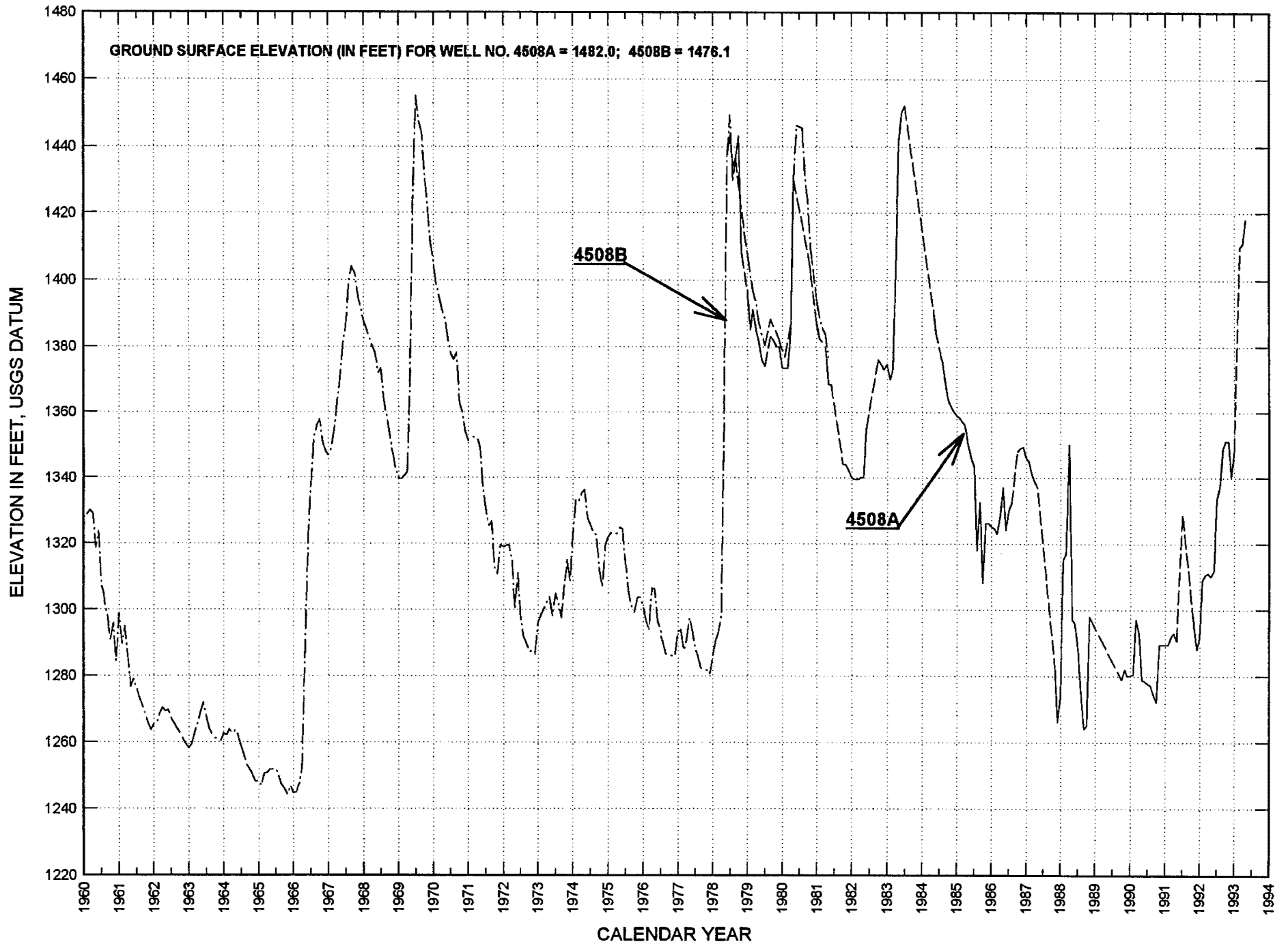

G35

ELEVATION IN FEET, USGS DATUM

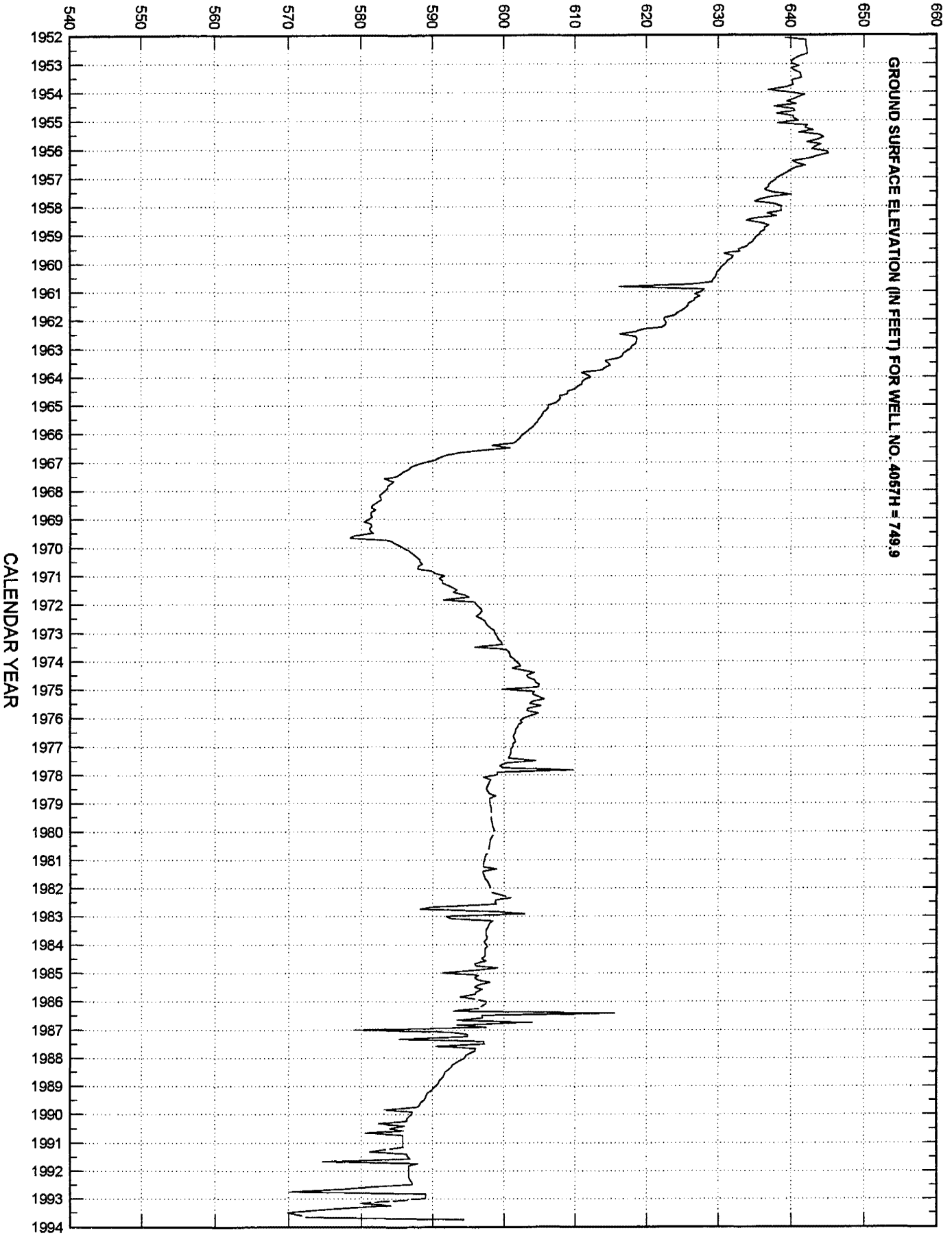

GROUNDWATER FLUCTUATIONS FOR WELL NO. 4057H
RAYMOND BASIN

CALENDAR YEAR

GROUNDWATER FLUCTUATIONS FOR WELL NOS. 7048A & 7048C NEAR CASTAIC JUNCTION, SANTA CLARITA VALLEY

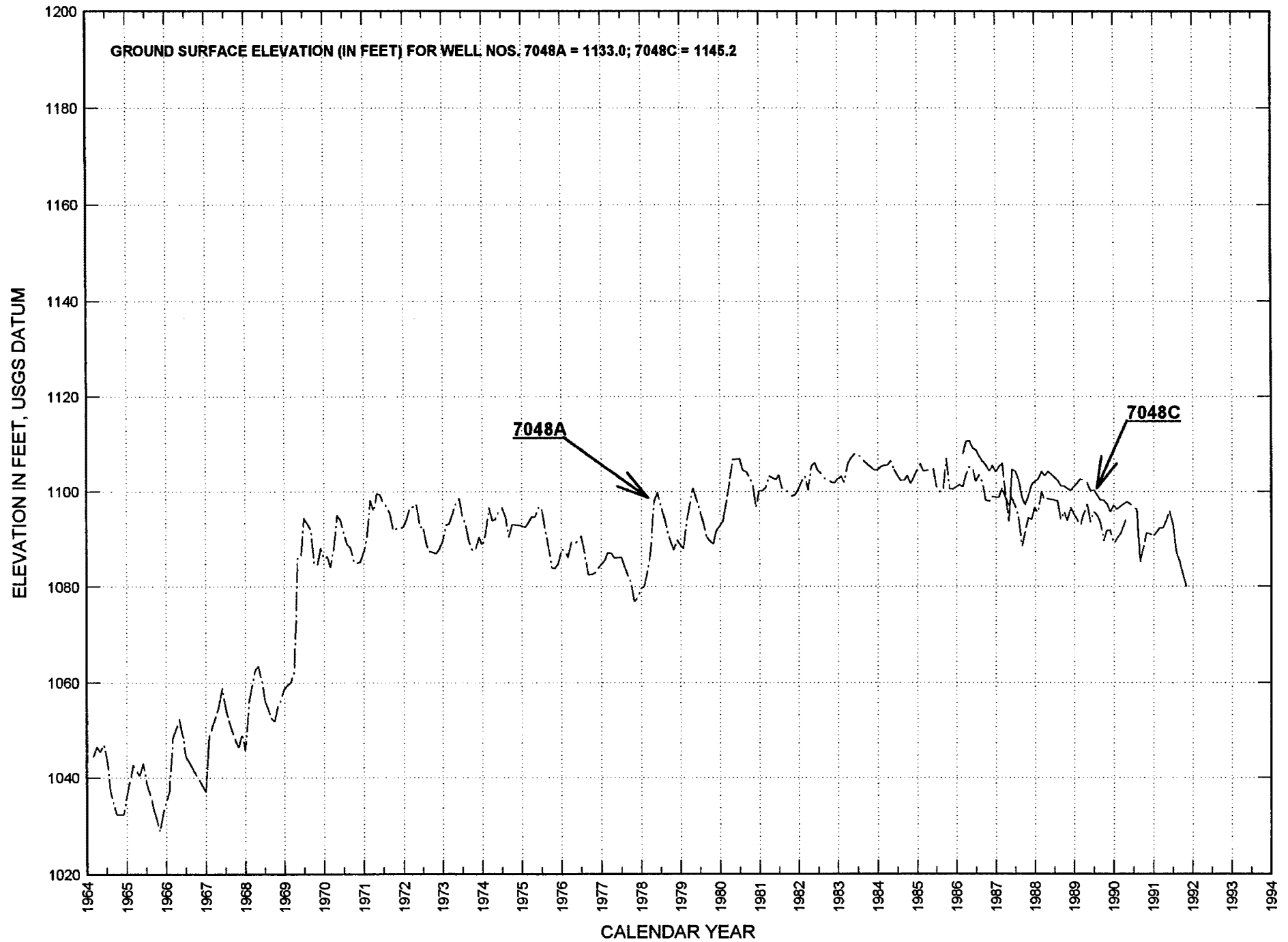

G39

GROUNDWATER FLUCTUATIONS FOR WELL NOS. 9962B, 9962C, 9962D & 9974 SOUTH OF LANCASTER, ANTELOPE VALLEY

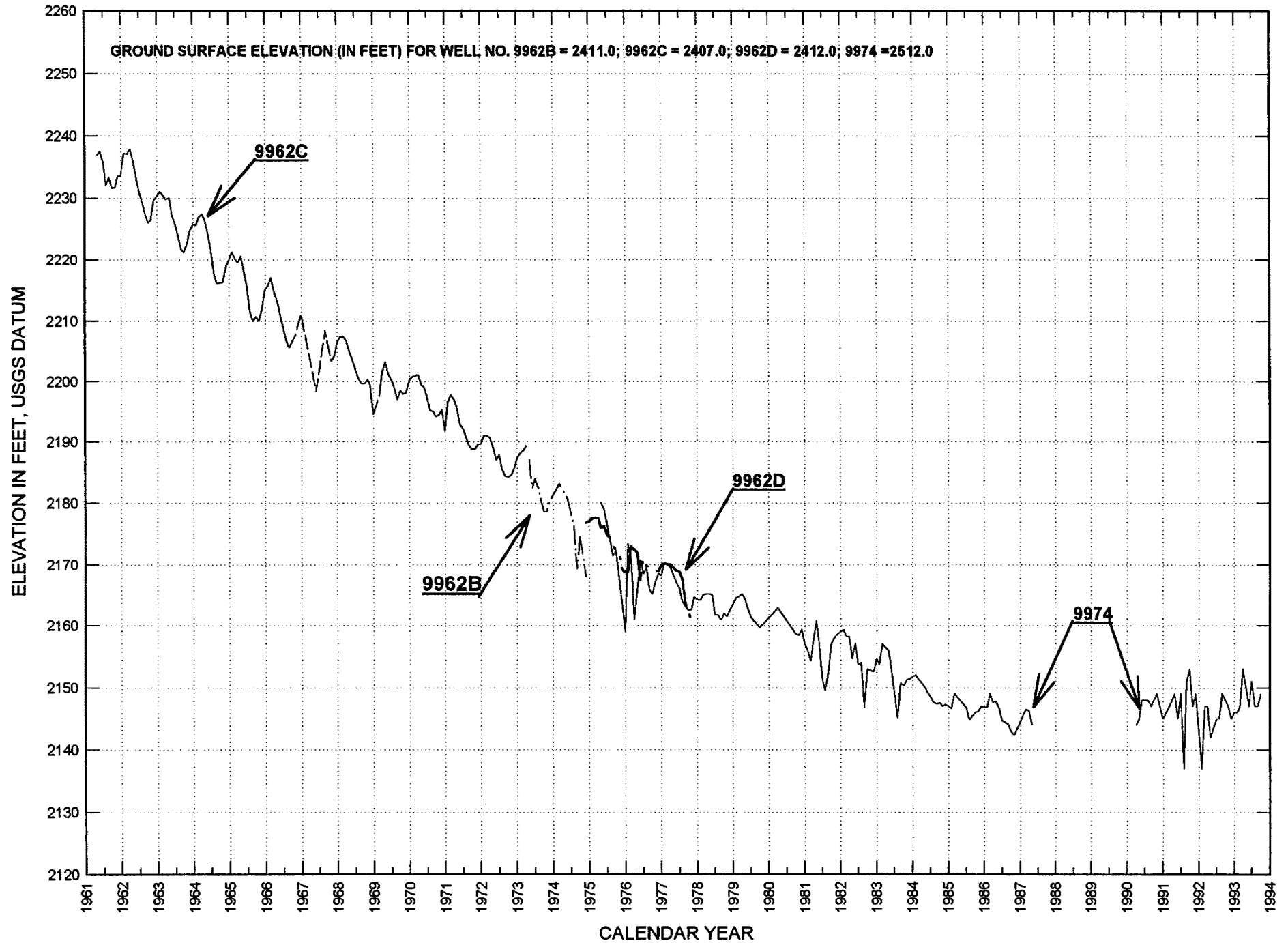

G41

GROUNDWATER FLUCTUATIONS FOR WELL NO. 8825

SOUTH OF PALMDALE, LITTLE ROCK

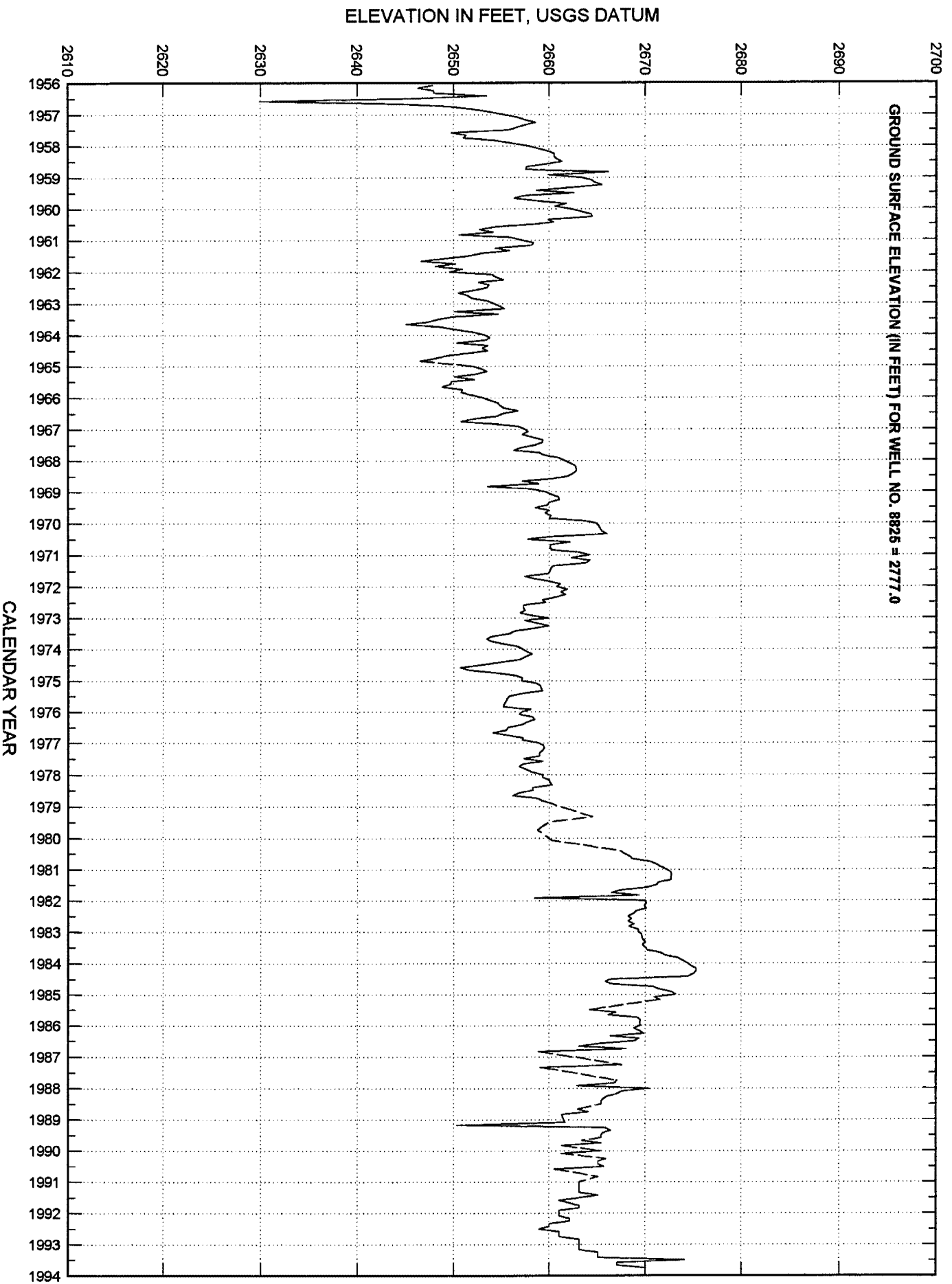

GROUNDWATER FLUCTUATIONS FOR WELL NO. 3872H

BURBANK, SAN FERNANDO VALLEY

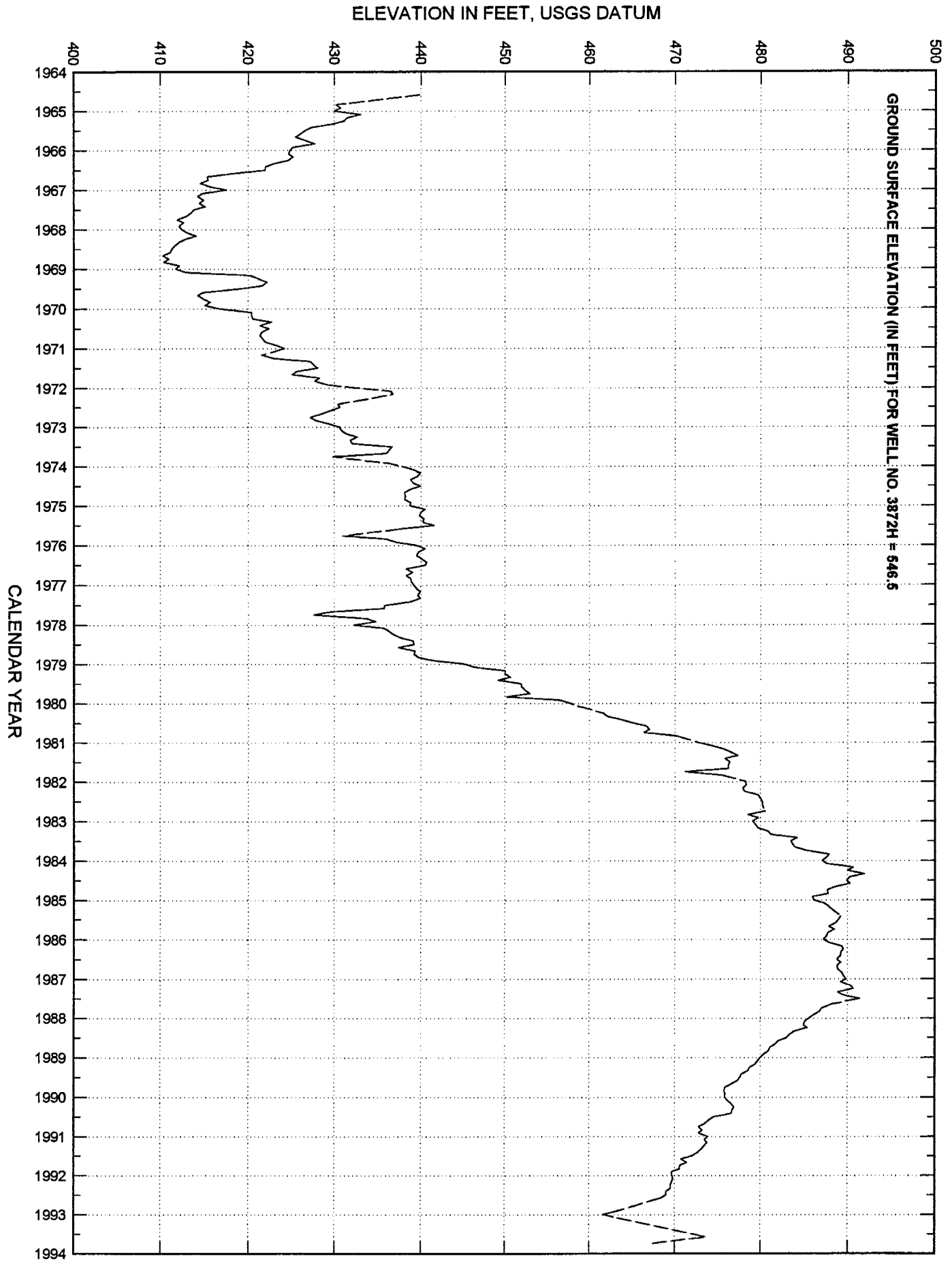

GROUNDWATER FLUCTUATIONS FOR WELL NO. 4709

CANOGA PARK, SAN FERNANDO VALLEY

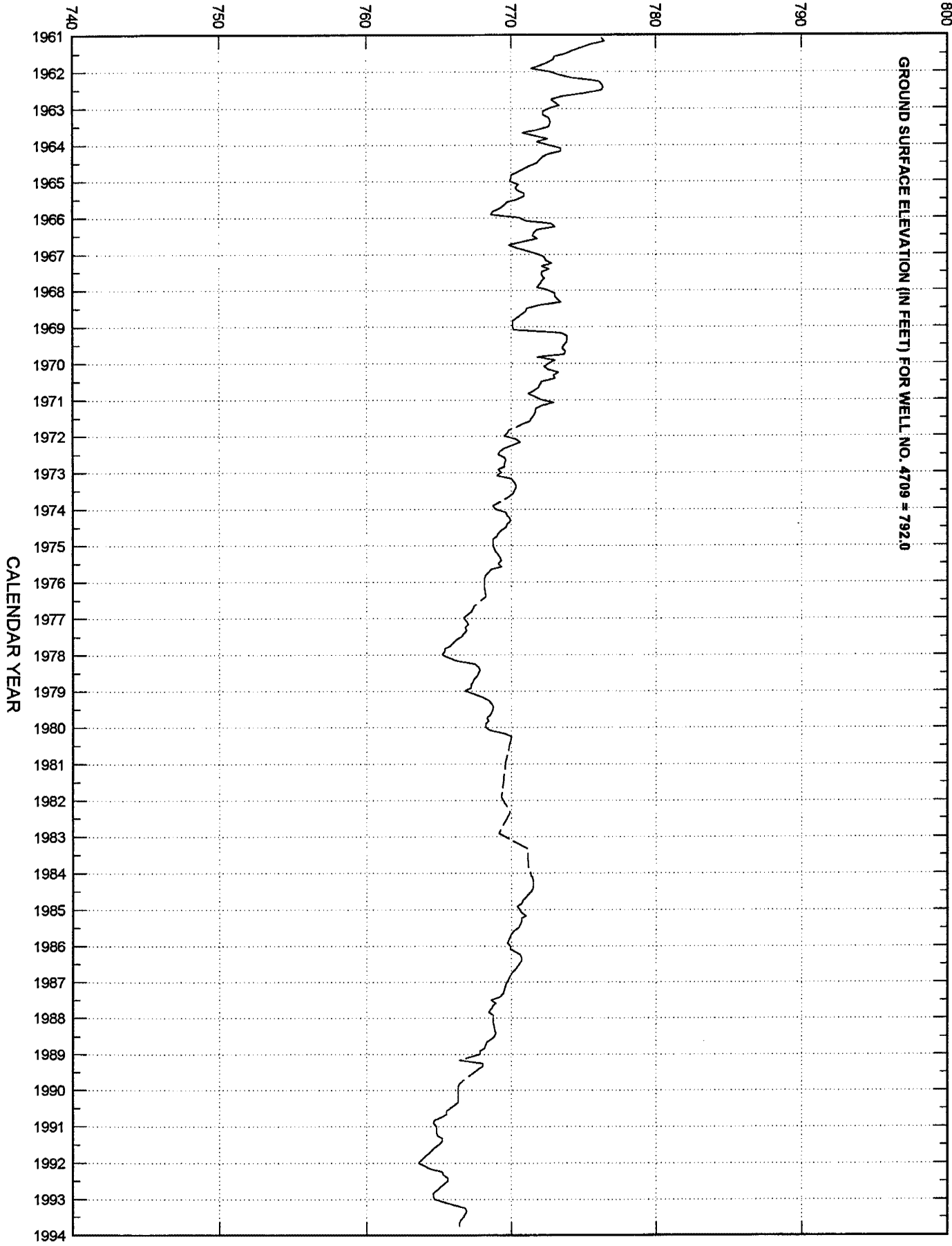

LOS ANGELES COUNTY DEPARTMENT OF PUBLIC WORKS GROUNDWATER BASINS AND RECHARGE FACILITIES

- 1** CENTRAL BASIN
 - A** DOMINGUEZ GAP S.G.
 - B** RIO HONDO COASTAL BASIN S.G.
 - C** SAN GABRIEL COASTAL BASIN S.G.
 - D** SAN GABRIEL RIVER (LOWER)
- 2** CHINO BASIN
- 3** CLAREMONT HEIGHTS BASIN
 - E** POMONA S.G.
(this facility is owned and operated by the Pomona Valley Protective Assn.)
 - F** SAN ANTONIO S.G.
(this facility is owned and operated by the Pomona Valley Protective Assn.)
 - G** THOMPSON CK. S.G.
(this facility is owned and operated by the Pomona Valley Protective Assn.)
- 4** EAGLE ROCK BASIN
- 5** FOOTHILL BASIN
 - H** SAN DIMAS CYN. S.G.

- 6** GLENDORA BASIN
 - I** BIG DALTON S.G.
 - J** LITTLE DALTON S.G.
- 7** HOLLYWOOD BASIN
- 8** LA HABRA BASIN
- 9** LIVE OAK BASIN
- 10** LOWER SAN GABRIEL CANYON BASIN
 - K** SAWPIT S.G.
- 11** MAIN SAN GABRIEL BASIN
 - L** BEN LOMOND S.G.
 - M** BUENA VISTA S.B.
 - N** CITRUS S.G.
 - O** EATON S.B.
 - P** IRWINDALE S.B./MANNING PIT
 - Q** PECK RD. S.B.
 - R** SAN GABRIEL RIVER (UPPER)
 - S** SANTA FE RESERVOIR S.G.
 - T** WALNUT S.B.
 - U** WHITTIER NARROWS W.C. DIVERSION CANAL (ZONE 1 DITCH)

- 12** POMONA BASIN
- 13** PUENTE BASIN
- 14** RAYMOND BASIN
 - V** ARROYO SECO S.G.
 - W** EATON S.G.
 - X** SANTA ANITA S.G.
 - Y** SIERRA MADRE S.G.
(this facility is owned and operated by the City of Sierra Madre)
- 15** SAN DIMAS BASIN
 - Z** LIVE OAK S.G.
- 16** SAN FERNANDO BASIN
 - AA** BRANFORD S.B.
 - BB** HANSEN S.G.
 - CC** HEADWORKS S.G.
(this facility is owned and operated by the City of Los Angeles - D.W.P.)
 - DD** LOPEZ S.G.
 - EE** PACOIMA S.G.
 - FF** TUJUNGA S.G.
(owned by the City of Los Angeles - D.W.P.)
(operated by the County of Los Angeles - L.A.C.D.P.W.)

- 17** SANTA MONICA BASIN
 - 18** SPADRA BASIN
 - 19** SYLMAR BASIN
 - 20** UPPER SAN GABRIEL CANYON BASIN
 - GG** FISH CYN. S.G.
(this facility is owned and operated by Cal American Water Co.)
 - HH** SAN GABRIEL CANYON S.G.
 - 21** VERDUGO BASIN
 - 22** WAY HILL BASIN
 - II** FORBES S.G.
 - 23** WEST COAST BASIN
- - SGVMWD
● - OWENS VALLEY (LA)
● - MWD OUTLETS

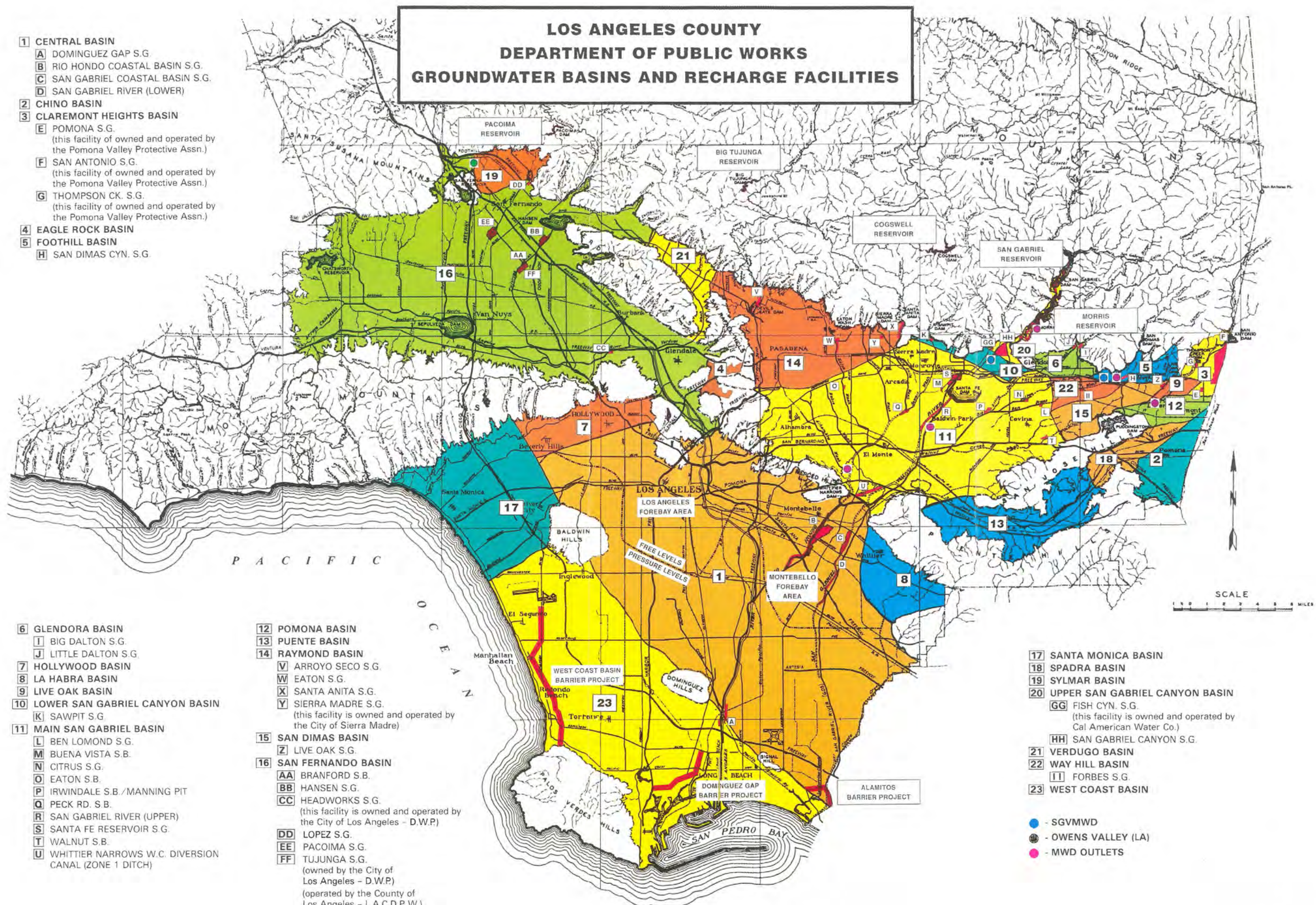

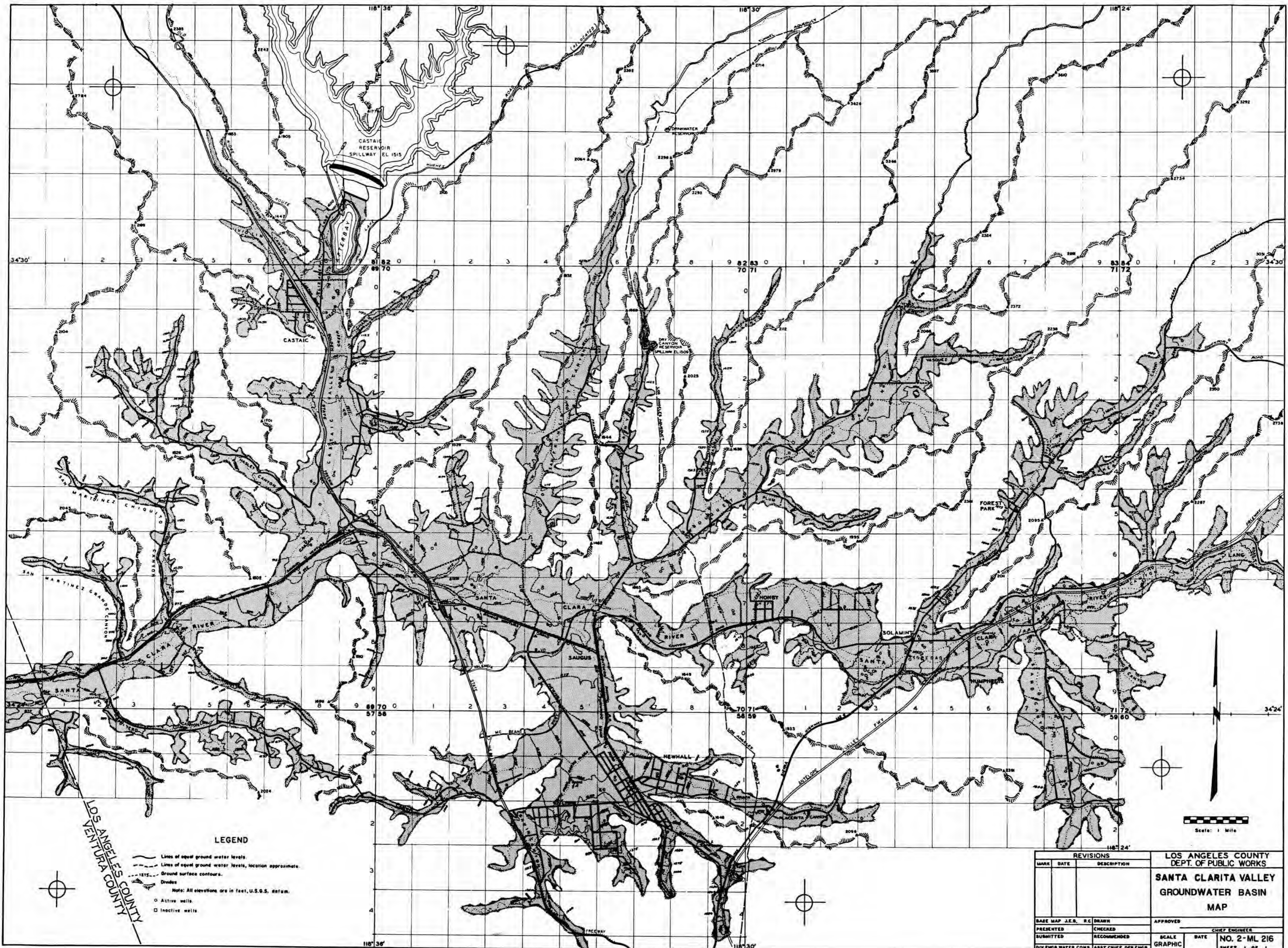

LEGEND

- Lines of equal ground water levels.
 - - - Lines of equal water levels, location approximate.
 - 1975 Ground surface contours.
 - Dredges
 - Active wells
 - Inactive wells
- Note: All elevations are in feet, U.S.S. datum.

LOS ANGELES COUNTY
VENTURA COUNTY

REVISIONS			LOS ANGELES COUNTY DEPT. OF PUBLIC WORKS	
MARK	DATE	DESCRIPTION		
			SANTA CLARITA VALLEY GROUNDWATER BASIN MAP	
BASE MAP J.E.B. R.C. DRAWN			APPROVED	
PRESENTED			CHECKED	
SUBMITTED			RECOMMENDED	
DIV. ENGR. WATER CONTL. ASST. CHIEF DEP. ENGR.			SCALE GRAPHIC	DATE
				NO. 2-ML 216
				SHEET 1 OF 1

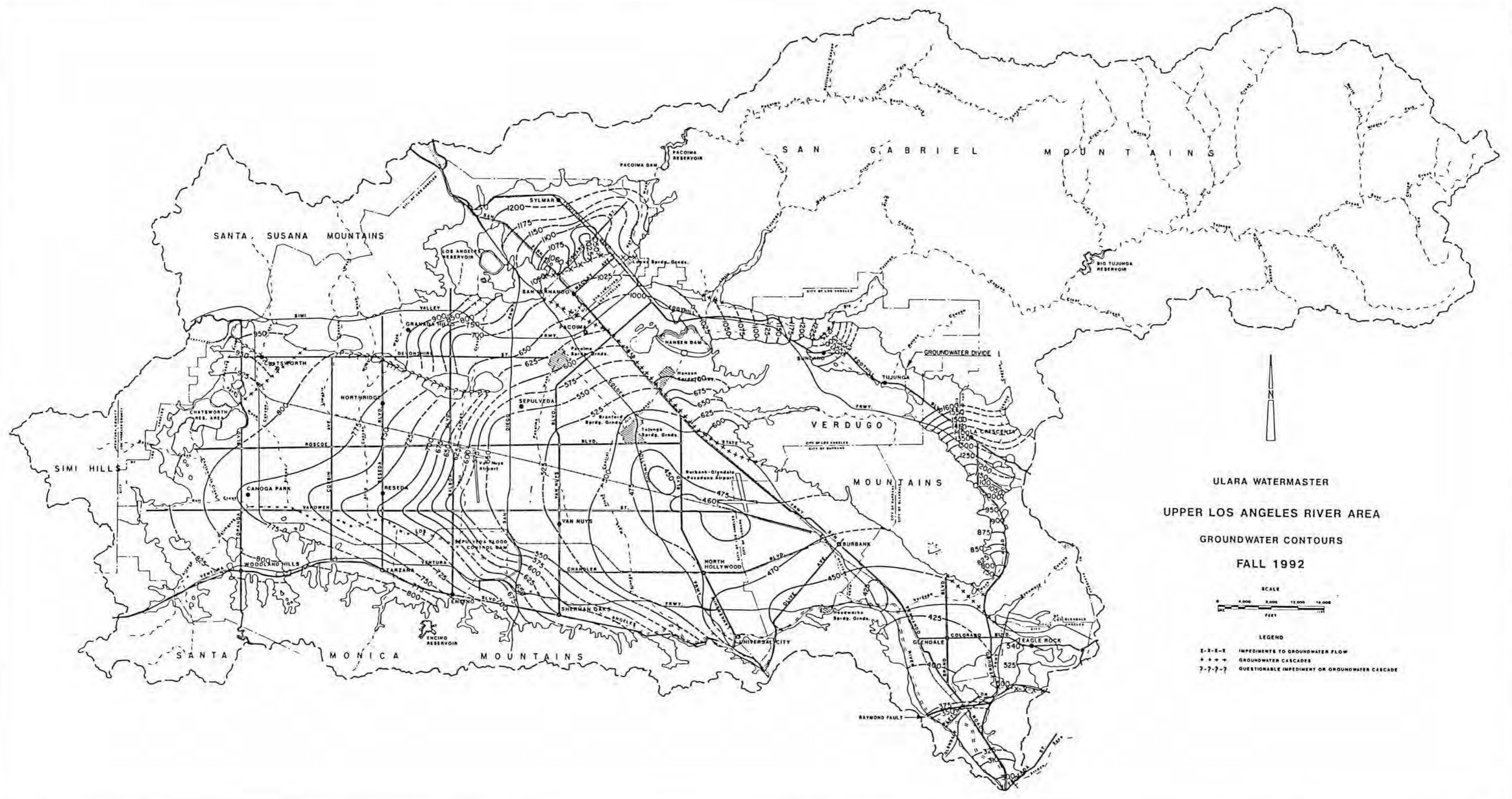

ULARA WATERMASTER
 UPPER LOS ANGELES RIVER AREA
 GROUNDWATER CONTOURS
 FALL 1992

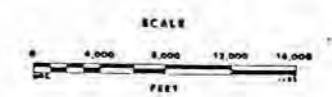

- LEGEND
- - - - - IMPEDIMENTS TO GROUNDWATER FLOW
 - + + + + + GROUNDWATER CASCADES
 - ?-?-?-? QUESTIONABLE IMPEDIMENT OR GROUNDWATER CASCADE

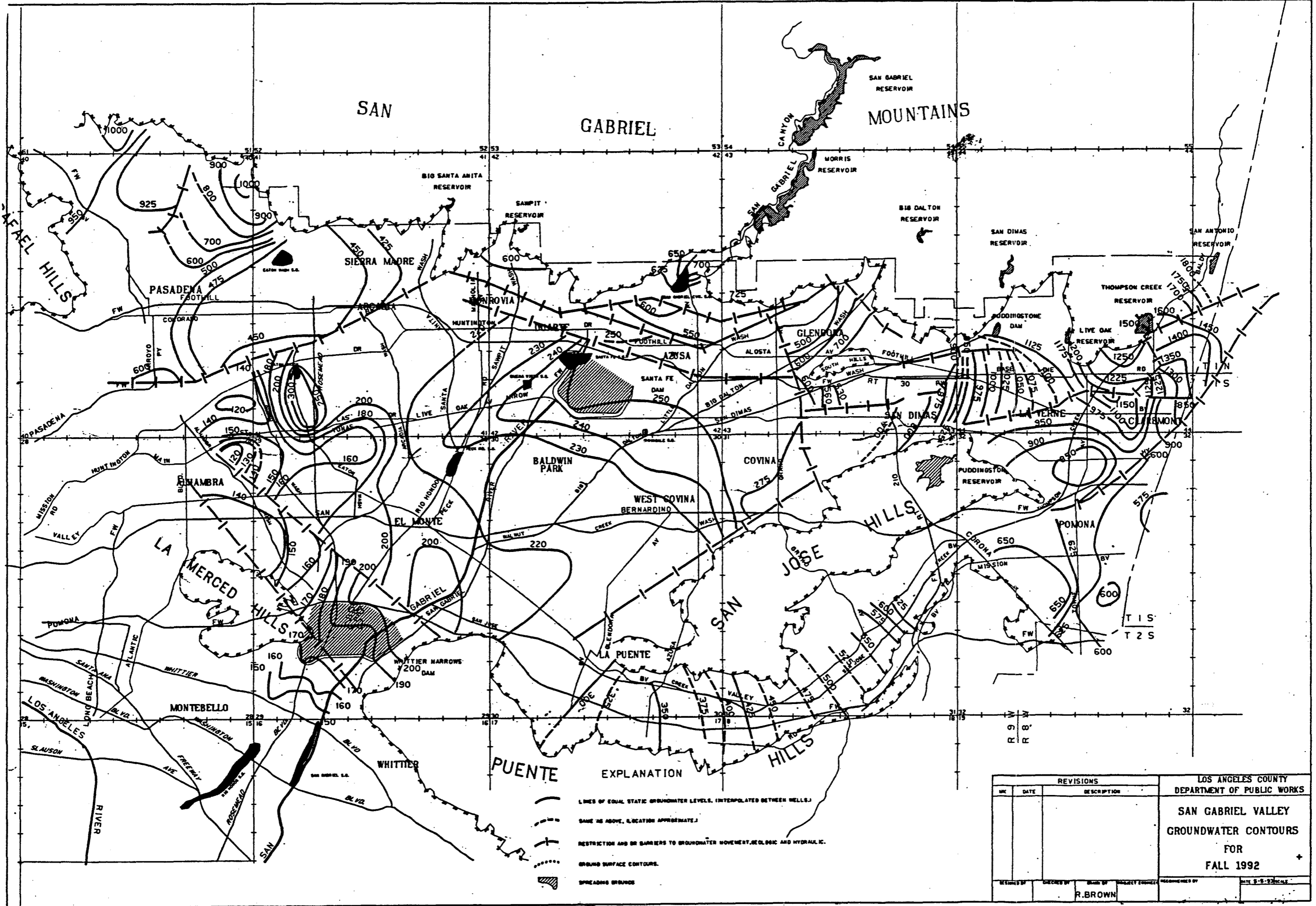

- EXPLANATION
- LINES OF EQUAL STATIC GROUNDWATER LEVELS, INTERPOLATED BETWEEN WELLS.
 - - - SAME AS ABOVE, LOCATION APPROXIMATE.
 - + - RESTRICTION AND OR BARRIERS TO GROUNDWATER MOVEMENT, GEOLOGIC AND HYDRAULIC.
 - GROUND SURFACE CONTOURS.
 - SPREADING GROUNDS.

REVISIONS			LOS ANGELES COUNTY DEPARTMENT OF PUBLIC WORKS	
NO.	DATE	DESCRIPTION		
			SAN GABRIEL VALLEY GROUNDWATER CONTOURS FOR FALL 1992	
DESIGNED BY	CHECKED BY	DRAWN BY	PROJECT ENGINEER	APPROVED BY
		R. BROWN		

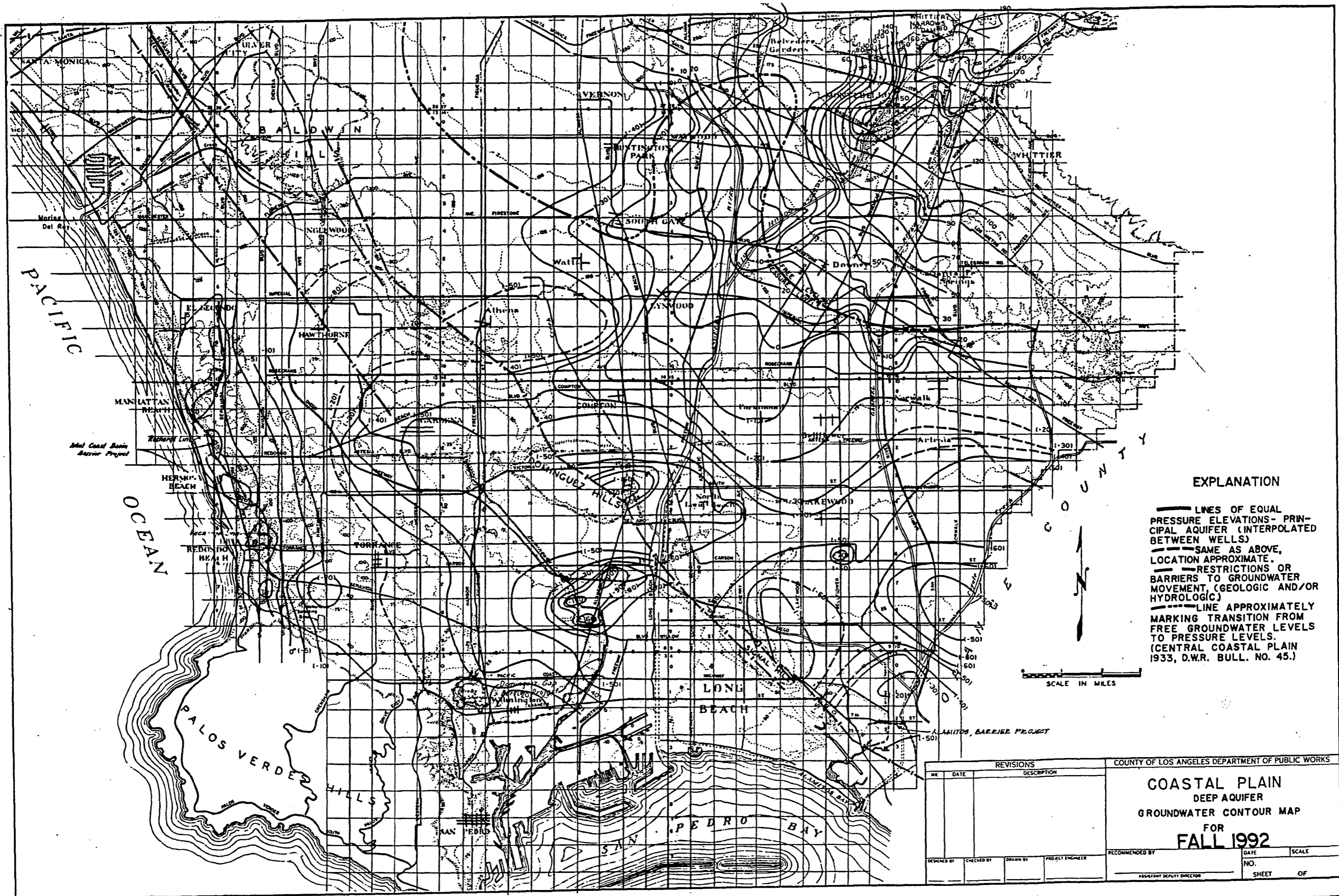

EXPLANATION

- LINES OF EQUAL PRESSURE ELEVATIONS - PRINCIPAL AQUIFER (INTERPOLATED BETWEEN WELLS)
- - - SAME AS ABOVE, LOCATION APPROXIMATE.
- - - RESTRICTIONS OR BARRIERS TO GROUNDWATER MOVEMENT, (GEOLOGIC AND/OR HYDROLOGIC)
- - - LINE APPROXIMATELY MARKING TRANSITION FROM FREE GROUNDWATER LEVELS TO PRESSURE LEVELS. (CENTRAL COASTAL PLAN 1933, D.W.R. BULL. NO. 45.)

SCALE IN MILES

REVISIONS				COUNTY OF LOS ANGELES DEPARTMENT OF PUBLIC WORKS			
NO.	DATE	DESCRIPTION		<p align="center">COASTAL PLAIN DEEP AQUIFER GROUNDWATER CONTOUR MAP FOR FALL 1992</p>			
DESIGNED BY	CHECKED BY	DRAWN BY	PROJECT ENGINEER			RECOMMENDED BY	DATE
						ASSISTANT DEPUTY DIRECTOR	SCALE
					NO.		
					SHEET		
					OF		

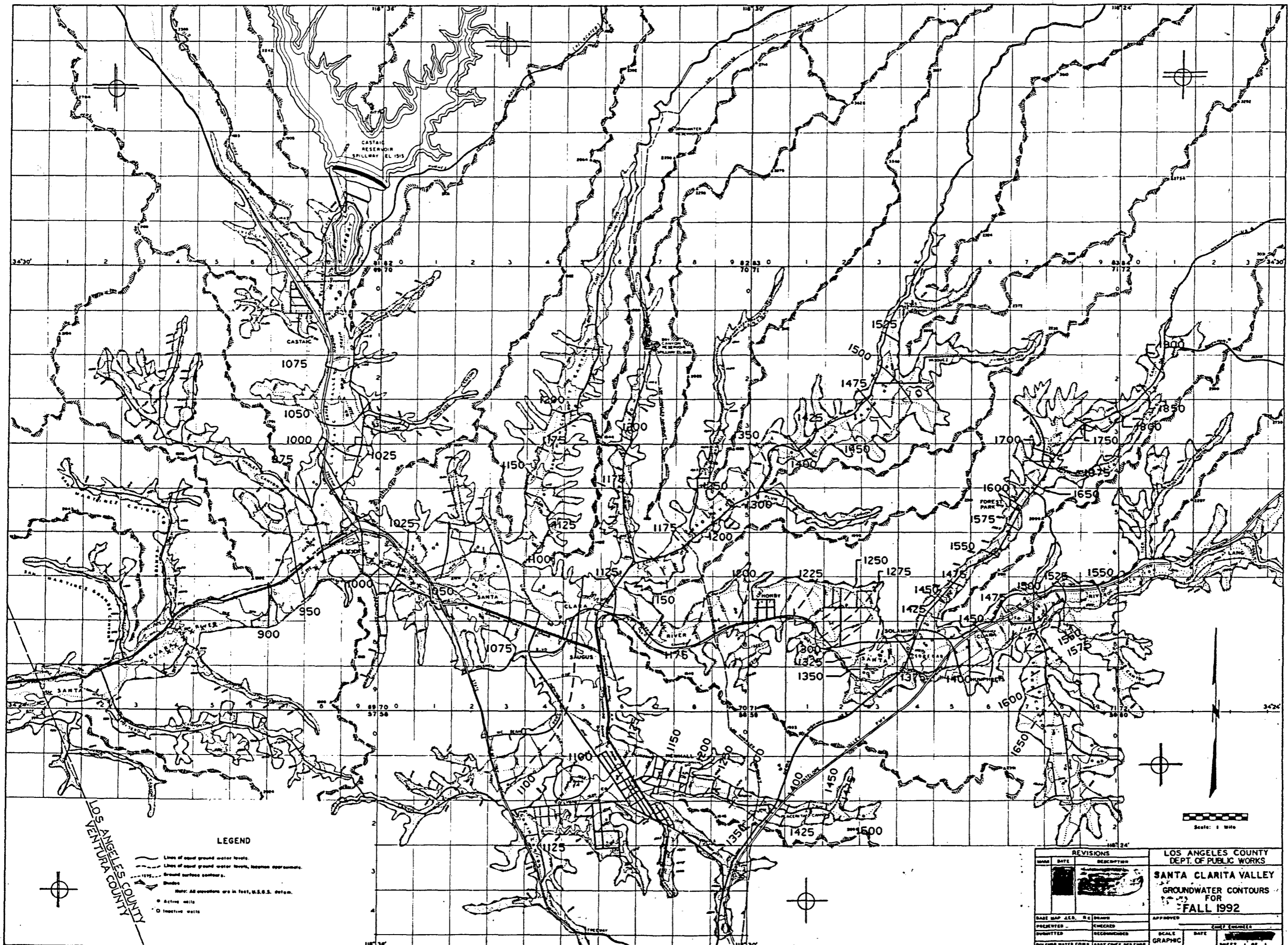

LOS ANGELES COUNTY
VENTURA COUNTY

LEGEND

- Lines of equal ground water levels.
- - - Lines of equal ground water levels, interim approximates.
- - - Ground surface contours.
- Shaded
- Note: All elevations are in feet, U.S.S.S. datum.
- Active wells
- Inactive wells

REVISIONS		DATE		DESCRIPTION	

LOS ANGELES COUNTY DEPT. OF PUBLIC WORKS	
SANTA CLARITA VALLEY GROUNDWATER CONTOURS FOR FALL 1992	
APPROVED	DATE
PREPARED BY	CHECKED
QUANTITY	RECOMMENDED
SCALE	DATE
GRAPHIC	
SHEET 1 OF 1	